

QUICK START GUIDE FOR DEMONSTRATION CIRCUIT 1072B 1A MONOLITHIC SYNCHRONOUS BUCK REGULATOR

LTC3561A

DESCRIPTION

Demonstration circuit 1072B is a step-down converter, using the LTC3561A monolithic synchronous buck regulator. The DC1072B has an input voltage range of 2.5V to 5.5V, and is capable of delivering up to 1A of output current. The output voltage of the DC1072B can be set as low as 0.8V, the reference voltage of the LTC3561A, and can go as high as 5V. At light load currents, the DC1072B operates in pulse-skipping mode - ideal for noise sensitive applications. Of course, in large load current applications, the DC1072B operates in continuous mode, providing high efficiency - over 95%. The DC1072B consumes less than 60 μ A of quiescent current during sleep operation, and during shutdown, it consumes less

than 1 μ A. The DC1072B has a standard operating frequency of 1 MHz, but can be adjusted to frequencies as high as 4 MHz. Because of the high switching frequency of the DC1072B, small, low profile surface mount components are used in the circuit. These features, plus the LTC3561A coming in a small 8-Lead DFN package, make the DC1072B a perfect match for battery-powered, hand-held applications.

Design files for this circuit board are available. Call the LTC factory.

TM - Burst Mode is a trademark of Linear Technology Corporation

Table 1.

Performance Summary ($T_A = 25^\circ\text{C}$)

| PARAMETER | CONDITIONS | VALUE |
|-------------------------------------|--|---|
| Minimum Input Voltage | | 2.5V |
| Maximum Input Voltage | | 5.5V |
| Output Voltage V_{OUT} Regulation | $V_{IN} = 2.5\text{V to } 5.5\text{V}$, $I_{OUT} = 0\text{A to } 1\text{A}$ | 1.2V $\pm 4\%$ (1.152V to 1.248V) 1.5V $\pm 4\%$ (1.44V to 1.56V) 1.8V $\pm 4\%$ (1.728V to 1.872V) |
| Typical Output Ripple V_{OUT} | $V_{IN} = 5\text{V}$, $I_{OUT} = 1\text{A}$ (20 MHz BW) | <20mV _{p-p} |
| Operation Mode | Pulse-Skipping - $V_{IN} = 3.3\text{V}$, $V_{OUT} = 1.8\text{V}$ | <100mA $\pm 0.1\%$ |
| Nominal Switching Frequency | | 1 MHz |

QUICK START PROCEDURE

Demonstration Circuit 1072B is easy to set up to evaluate the performance of the LTC3561A. For proper measurement equipment configuration, set up the circuit according to the diagram in **Figure 1**. Before proceeding to test, insert

shunts into JP1 OFF position, which connects the RUN pin to ground (GND), and thus, shuts down the circuit, and the 1.2V position of JP2.

NOTE: When measuring the input or output voltage ripple, care must be taken to avoid a long

QUICK START GUIDE FOR DEMONSTRATION CIRCUIT 1072B

1A MONOLITHIC SYNCHRONOUS BUCK REGULATOR

ground lead on the oscilloscope probe. Measure the input or output voltage ripple by touching the probe tip directly across the Vin or Vout and GND terminals. See **Figure 2** for proper scope probe technique.

1. With the DC1072B set up according to the proper measurement and equipment in **Figure 1**, apply 3.3V at Vin (Do not hot-plug Vin or increase Vin over the rated maximum supply voltage of 5.5V, or the part may be damaged.). Measure Vout; it should read 0V. If desired, one can measure the shutdown supply current at this point. The supply current will be approximately 10 uA, or less, in shutdown.
2. Turn on the circuit by inserting the shunt in header JP1 into the ON position. The output voltage should be regulating. Measure Vout - it should measure 1.2V +/- 2% (1.176V to 1.224V).
3. Vary the input voltage from 2.5V to 5.5V and adjust the load current from 0 to 1A. Vout

should read between 1.2V +/- 4% (1.152V to 1.248V).

4. Measure the output ripple voltage at any output current level; it usually will measure less than 20 mVAC.
5. Observe the voltage waveform at the switch node. Verify the switching frequency is between 850 kHz and 1.15 MHz ($T = 1.176 \mu\text{s}$ and $0.87 \mu\text{s}$), and that the switch node waveform is rectangular in shape.

Insert jumper JP1 shunt into the OFF position and move the 1.2V Vout shunt into any of the remaining output voltage options: 1.5V or 1.8V. Just as in the 1.2Vout test, the output voltage should read Vout +/- 2% tolerance under static line and load conditions, and +/- 1% tolerance under dynamic line and load conditions (+/- 2% total).

When finished, turn off the circuit (connecting the RUN pin to ground) by inserting the shunt in header JP1 into the OFF (upper) position.

Connection Diagram

QUICK START GUIDE FOR DEMONSTRATION CIRCUIT 1072B

1A MONOLITHIC SYNCHRONOUS BUCK REGULATOR

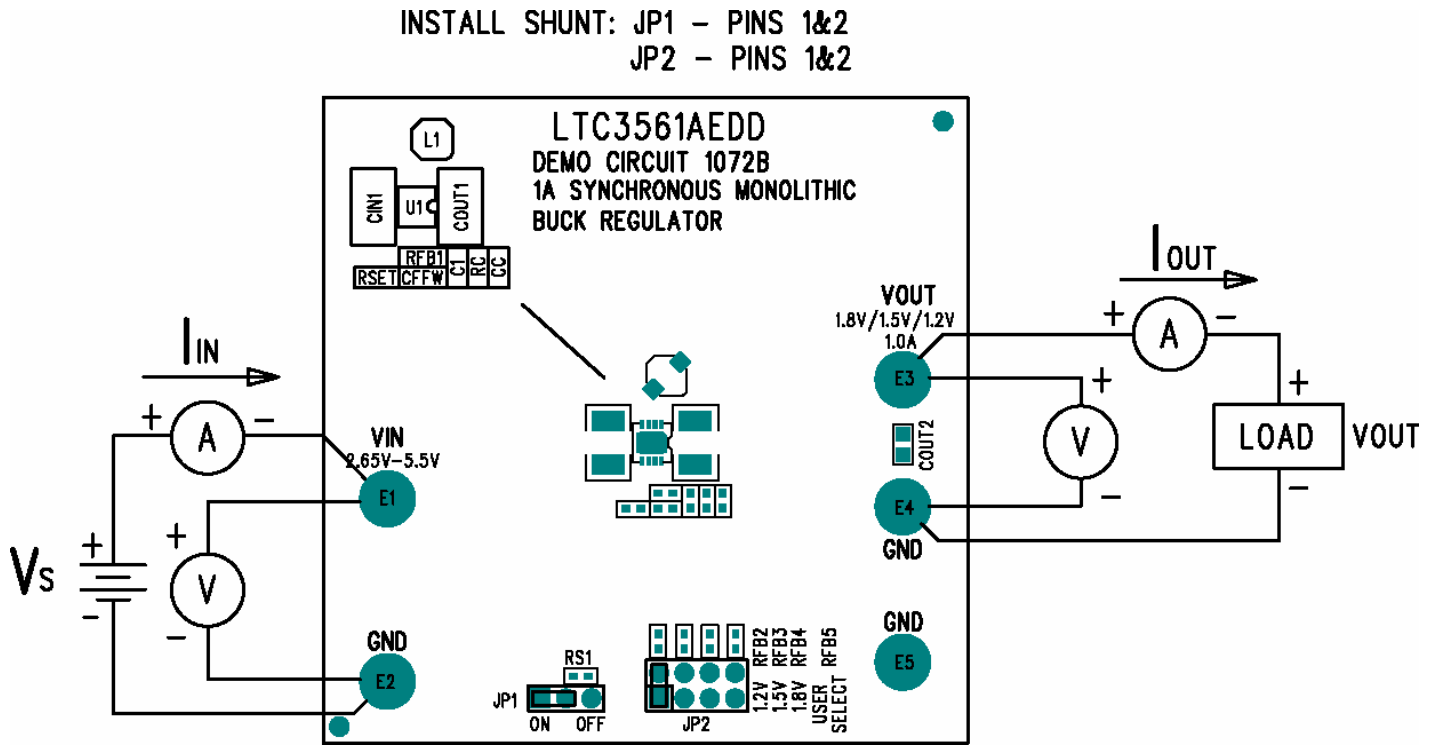

Figure 1. Proper Measurement Equipment Setup

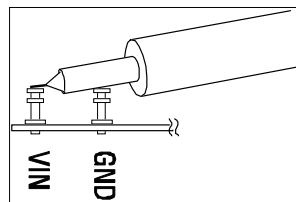

Figure 2. Measuring Input or Output Ripple

QUICK START GUIDE FOR DEMONSTRATION CIRCUIT 1072B

1A MONOLITHIC SYNCHRONOUS BUCK REGULATOR

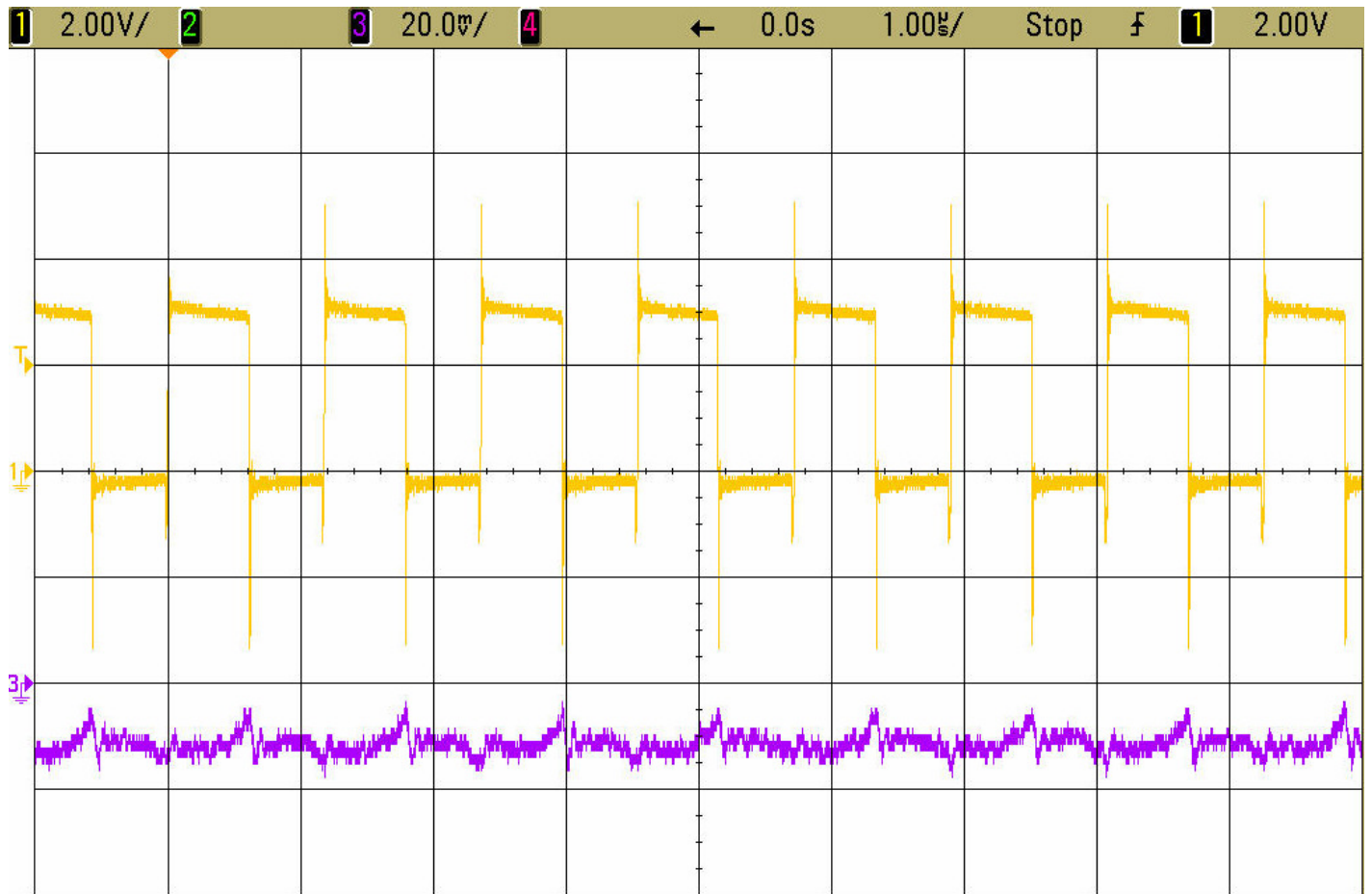

Figure 3. Switching Operation
 $V_{IN} = 3.3V$, $V_{OUT} = 1.5V$, 1A Output Current
Trace 1: Switch Voltage (2V/div)
Trace 3: Output Voltage (20mV/div AC)

QUICK START GUIDE FOR DEMONSTRATION CIRCUIT 1072B

1A MONOLITHIC SYNCHRONOUS BUCK REGULATOR

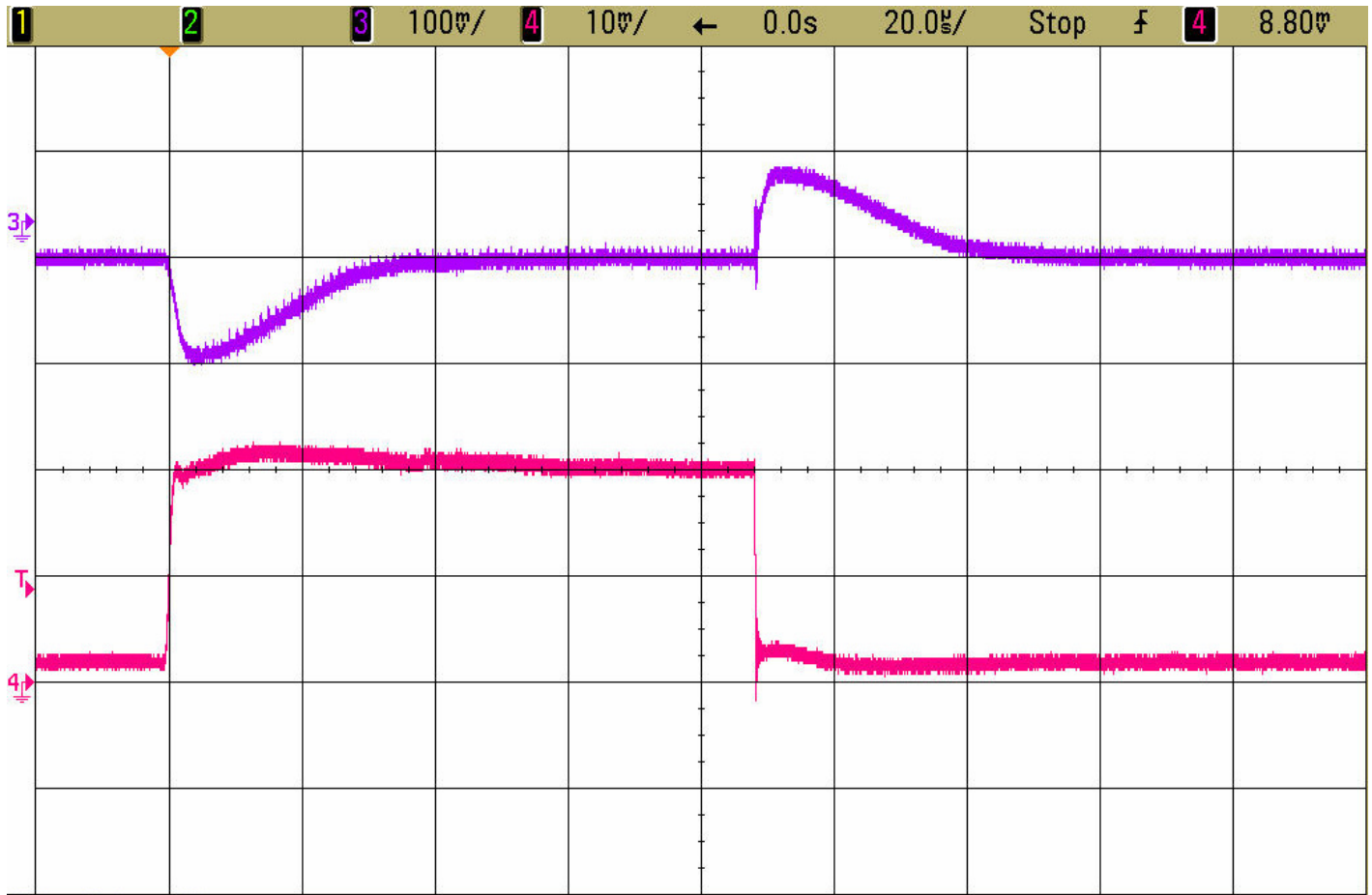
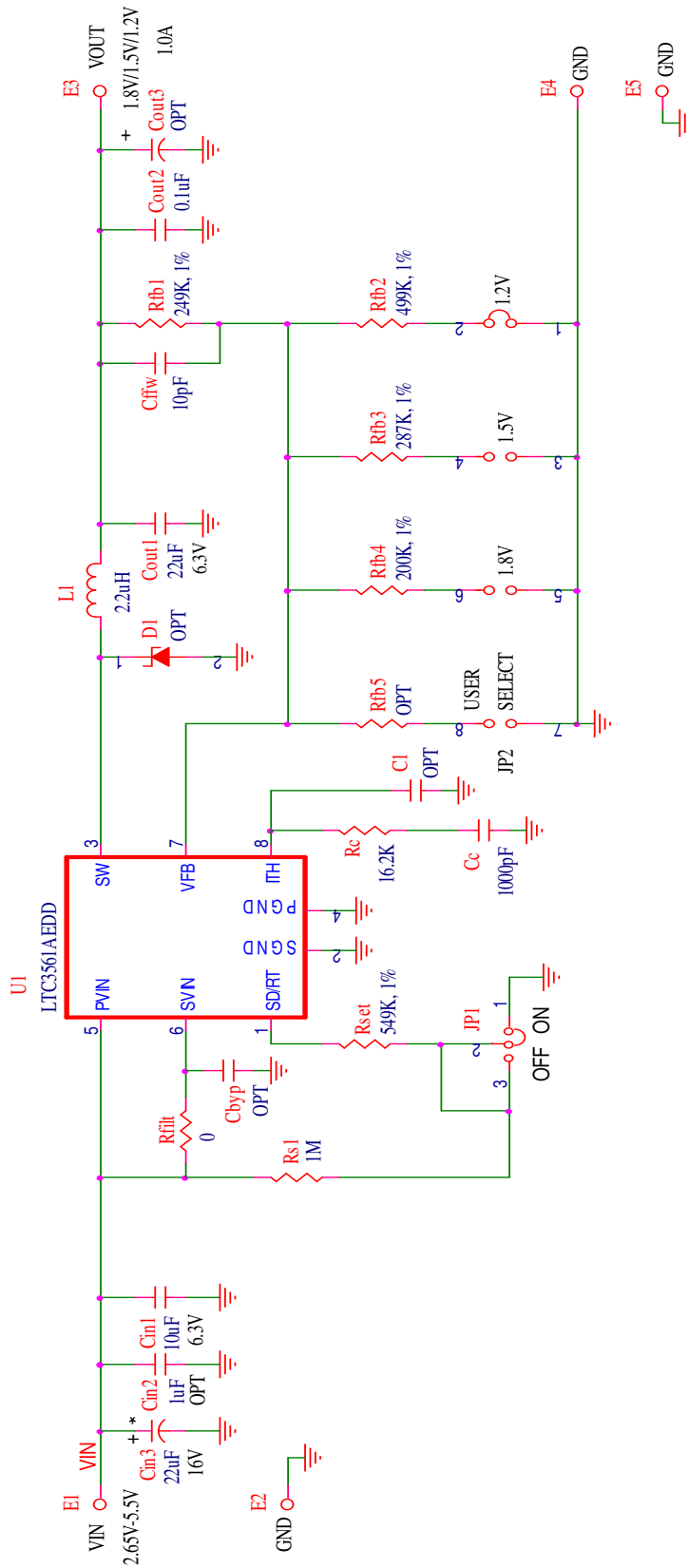

Figure 4. Load Step Response
 $V_{IN} = 3.3V$, $V_{OUT} = 1.5V$, 900mA Load Step (0.1A \leftrightarrow 1A)
Trace 3: Output Voltage (100mV/div AC)
Trace 4: Output Current (500 mA/div)

QUICK START GUIDE FOR DEMONSTRATION CIRCUIT 1072B

1A MONOLITHIC SYNCHRONOUS BUCK REGULATOR



X-ON Electronics

Largest Supplier of Electrical and Electronic Components

Click to view similar products for [Power Management IC Development Tools](#) category:

Click to view products by [Analog Devices](#) manufacturer:

Other Similar products are found below :

[EVAL-ADM1168LQEBZ](#) [EVB-EP5348UI](#) [MIC23451-AAAYFL EV](#) [MIC5281YMME EV](#) [DA9063-EVAL](#) [ADP122-3.3-EVALZ](#) [ADP130-0.8-EVALZ](#) [ADP130-1.2-EVALZ](#) [ADP130-1.5-EVALZ](#) [ADP130-1.8-EVALZ](#) [ADP1714-3.3-EVALZ](#) [ADP1716-2.5-EVALZ](#) [ADP1740-1.5-EVALZ](#) [ADP1752-1.5-EVALZ](#) [ADP1828LC-EVALZ](#) [ADP1870-0.3-EVALZ](#) [ADP1871-0.6-EVALZ](#) [ADP1873-0.6-EVALZ](#) [ADP1874-0.3-EVALZ](#) [ADP1882-1.0-EVALZ](#) [ADP199CB-EVALZ](#) [ADP2102-1.25-EVALZ](#) [ADP2102-1.875EVALZ](#) [ADP2102-1.8-EVALZ](#) [ADP2102-2-EVALZ](#) [ADP2102-3-EVALZ](#) [ADP2102-4-EVALZ](#) [ADP2106-1.8-EVALZ](#) [ADP2147CB-110EVALZ](#) [AS3606-DB](#) [BQ24010EVM](#) [BQ24075TEVM](#) [BQ24155EVM](#) [BQ24157EVM-697](#) [BQ24160EVM-742](#) [BQ24296MEVM-655](#) [BQ25010EVM](#) [BQ3055EVM](#) [NCV891330PD50GEVB](#) [ISLUSBI2CKIT1Z](#) [LM2744EVAL](#) [LM2854EVAL](#) [LM3658SD-AEV/NOPB](#) [LM3658SDEV/NOPB](#) [LM3691TL-1.8EV/NOPB](#) [LM4510SDEV/NOPB](#) [LM5033SD-EVAL](#) [LP38512TS-1.8EV](#) [EVAL-ADM1186-1MBZ](#) [EVAL-ADM1186-2MBZ](#)