

DESCRIPTION

Demonstration circuit 1092 is a monolithic step-down DC/DC switching converter featuring the LT[®]1933H. The board is optimized for 3.3V output at up to 500mA load current for a steady state input voltage range of 4.5V to 36V. With its H-grade temperature rating, wide input voltage range, high current internal power switch, low dropout operation, 500kHz switching frequency and tiny DFN package, the LT1933H is a very versatile and powerful IC for DC/DC converters that require extremely compact space, high efficiency and high input voltage with a high temperature range.

The LT1933H 500kHz switching frequency allows all of the components to be small, surface mount devices. The board is designed to run at maximum power up to 85°C ambient. The IC is rated for up to 150°C junction temperature. The current-mode control topology creates fast transient response and good loop stability with a minimum number of external components. The low resistance internal power switch (0.37V V_{CEsat}) achieves high efficiencies of up to 84%. The shutdown pin can be used to program undervoltage lockout or place the part in micropower

shutdown, reducing supply current to less than 2 μ A by driving the pin low (*without R1 installed*). The internal soft start function reduces input current surge during start-up.

The LT1933H datasheet gives a complete description of the part, operation and applications information. The datasheet must be read in conjunction with this Quick Start Guide for demonstration circuit 1092. In particular, the datasheet section on 'Thermal Calculations' is important for estimating whether a given application's combination of input voltage, load current, ambient temperature and frequency will cause the LT1933H to exceed its absolute maximum rated junction temperature. The LT1933H is assembled in a small DFN package. Proper board layout is essential for maximum thermal performance. See the datasheet section 'Layout Considerations'.

Design files for this circuit board are available. Call the LTC factory.

LT is a trademark of Linear Technology Corporation

QUICK START PROCEDURE

Demonstration circuit 1092 is easy to set up to evaluate the performance of the LT1933H. Refer to Figure 1 for proper measurement equipment setup and follow the procedure below:

NOTE: Make sure that the input voltage does not exceed 36V.

NOTE: The shutdown function is optional and its terminal can be left floating (disconnected) if shutdown is not being used.

NOTE: Do not hot-plug the input voltage terminal VIN. The absolute maximum voltage on VIN is 36V and hot-plugging a power supply through wire leads to the demonstration circuit can cause the voltage on the extremely low-ESR ceramic input capacitor to ring

to twice its DC value. In order to protect the IC, a higher ESR Aluminum Electrolytic capacitor, C4, is placed at the input terminals. This may protect against some, but not all, input transients due to hot-plugging with a power supply. *See Application Note 88 for more details.*

NOTE: Connect the power supply (with power off), load, and meters as shown in Figure 1.

1. After all connections are made, turn on input power and verify that the output voltage is 3.3V.

NOTE: If the output voltage is too low, temporarily disconnect the load to make sure that the load is not set too high.

QUICK START GUIDE FOR DEMONSTRATION CIRCUIT 1092

36V 500KHZ H-GRADE DFN STEP-DOWN REGULATOR

2. Once the proper output voltages are established, adjust the load within the operating range and observe the output voltage regulation, ripple voltage, efficiency and other parameters.

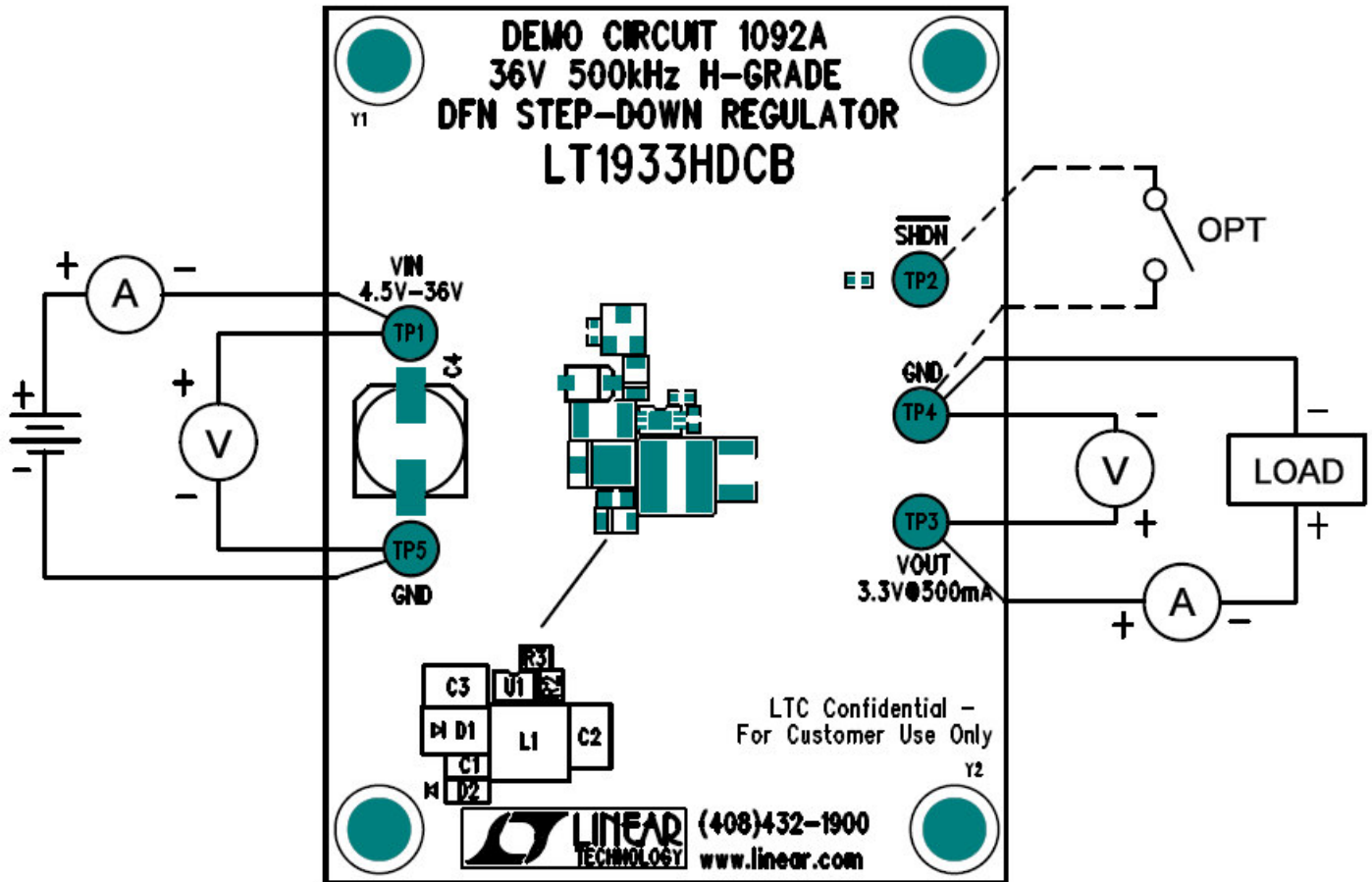
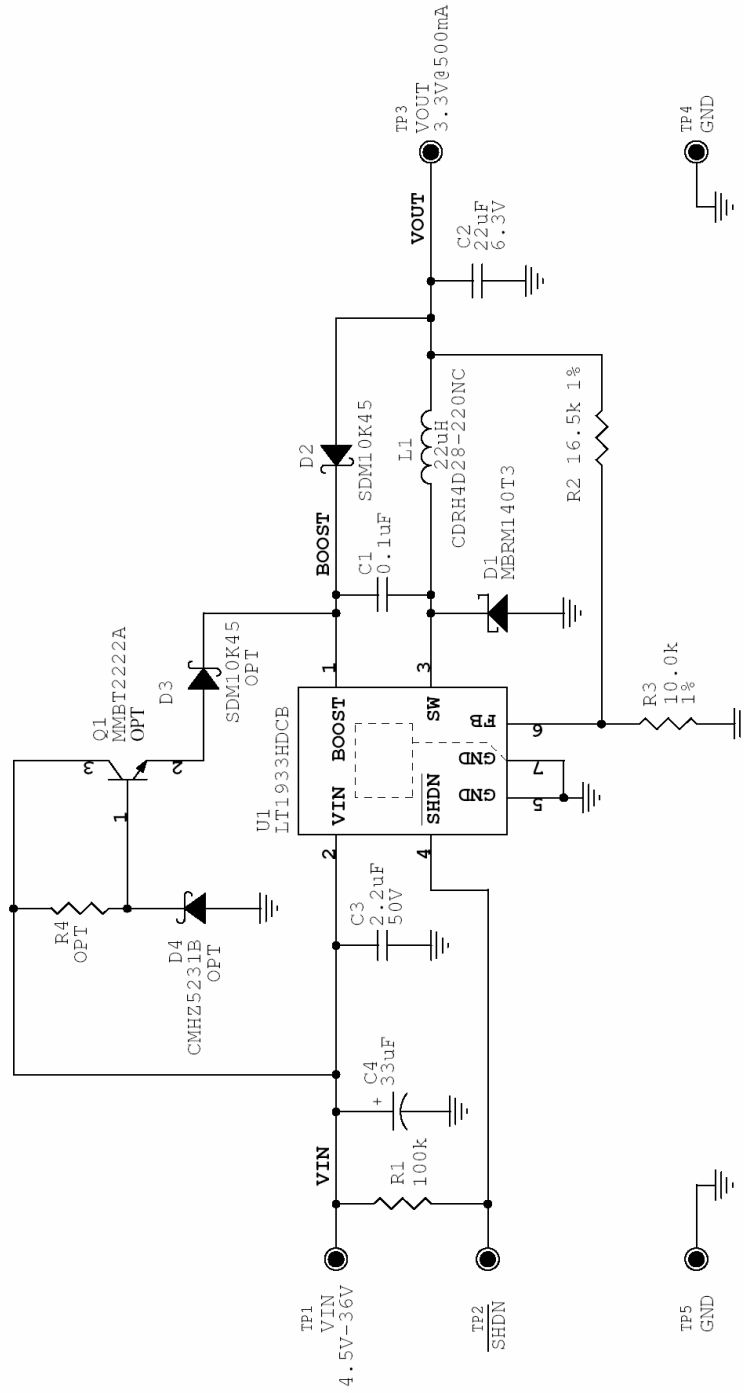

Figure 1. Proper Measurement Equipment Setup

QUICK START GUIDE FOR DEMONSTRATION CIRCUIT 1092

36V 500KHZ H-GRADE DFN STEP-DOWN REGULATOR

This circuit is proprietary to Linear Technology and supplied for use with Linear Technology parts.
Customer Notice: Linear Technology has made a best effort to design a circuit that meets customer-supplied specifications; however, it remains the customer's responsibility to verify proper and reliable operation in the actual application. Component substitution and printed circuit board layout may significantly affect circuit performance or reliability. Contact Linear Applications Engineering for assistance.



CONTRACT NO.

APPROVALS	DATE
DRAWN MI	03/31/06
CHECKED	
APPROVED	
ENGINEER	
DESIGNER	



TITLE SCH, LT1933HDCB, 36V 500kHz H-GRADE DFN STEP-DOWN REGULATOR

SIZE	ICAGE CODE	DWG NO	REV
A		DC1092A	2

Monday, October 02, 2006

SCALE:	NONE	FILENAME:	1092A-2.DSN	SHEET	1	OF	1
--------	------	-----------	-------------	-------	---	----	---

REVISION HISTORY				
ECO	REV	DESCRIPTION	DATE	APPROVED
	2	PROTO	09/20/06	

X-ON Electronics

Largest Supplier of Electrical and Electronic Components

Click to view similar products for [Power Management IC Development Tools](#) category:

Click to view products by [Analog Devices](#) manufacturer:

Other Similar products are found below :

[EVAL-ADM1168LQEBZ](#) [EVB-EP5348UI](#) [MIC23451-AAAYFL EV](#) [MIC5281YMME EV](#) [DA9063-EVAL](#) [ADP122-3.3-EVALZ](#) [ADP130-0.8-EVALZ](#) [ADP130-1.2-EVALZ](#) [ADP130-1.5-EVALZ](#) [ADP130-1.8-EVALZ](#) [ADP1714-3.3-EVALZ](#) [ADP1716-2.5-EVALZ](#) [ADP1740-1.5-EVALZ](#) [ADP1752-1.5-EVALZ](#) [ADP1828LC-EVALZ](#) [ADP1870-0.3-EVALZ](#) [ADP1871-0.6-EVALZ](#) [ADP1873-0.6-EVALZ](#) [ADP1874-0.3-EVALZ](#) [ADP1882-1.0-EVALZ](#) [ADP199CB-EVALZ](#) [ADP2102-1.25-EVALZ](#) [ADP2102-1.875EVALZ](#) [ADP2102-1.8-EVALZ](#) [ADP2102-2-EVALZ](#) [ADP2102-3-EVALZ](#) [ADP2102-4-EVALZ](#) [ADP2106-1.8-EVALZ](#) [ADP2147CB-110EVALZ](#) [AS3606-DB](#) [BQ24010EVM](#) [BQ24075TEVM](#) [BQ24155EVM](#) [BQ24157EVM-697](#) [BQ24160EVM-742](#) [BQ24296MEVM-655](#) [BQ25010EVM](#) [BQ3055EVM](#) [NCV891330PD50GEVB](#) [ISLUSBI2CKIT1Z](#) [LM2744EVAL](#) [LM2854EVAL](#) [LM3658SD-AEV/NOPB](#) [LM3658SDEV/NOPB](#) [LM3691TL-1.8EV/NOPB](#) [LM4510SDEV/NOPB](#) [LM5033SD-EVAL](#) [LP38512TS-1.8EV](#) [EVAL-ADM1186-1MBZ](#) [EVAL-ADM1186-2MBZ](#)