

QUICK START GUIDE FOR DEMONSTRATION CIRCUIT 1099

PUSH BUTTON ON/OFF CONTROLLER WITH BATTERY AND SUPPLY MONITORING

LTC2953CDD-1

DESCRIPTION

Demonstration circuit 1099 features the LTC2953, a push button On/Off controller that manages system power via a push button interface. An enable output toggles system power while an interrupt output provides debounced push button status. The interrupt output can be used in menu driven applications to request a system power down.

The length of time that the push button must be held low for a power down is configurable with an external capacitor. The LTC2953 allows a user to force an immediate power down by tying /INT with /KILL and a push button turn off.

The LTC2953 also features input and output supply monitors. An uncommitted power fail comparator provides real time input monitor threshold information, while a de-glitched under voltage lockout comparator gracefully initiates a system power down. The under voltage lockout comparator prevents from powering from a bad battery.

The adjustable supply monitor input is compared against an accurate internal 0.5V reference. The reset output remains low until the supply monitor input has been in compliance for 200ms.

The DC1099 accepts voltages of 2.7V to 27V over the operating range of the LTC2953 input voltage. The LTC2953 draws only 12uA of current. Reverse polarity protection is provided with RPP and CPP on the DC1099. Two versions of the part accommodate either positive or negative enable polarities. For the DC1099, the LTC2953-1 with Enable active high is shown.

On the DC1099, an LT3010 is used to demonstrate a supply with its shutdown pin driven by the enable of the LTC2953.

Design files for this circuit board are available. Call the LTC factory.

LTC is a trademark of Linear Technology Corporation

Table 1. Typical Performance Summary (T_A = 25°C)

PARAMETER	CONDITION	VALUE
Input Voltage Range V _{IN}	Operating Range (Note 1)	2.7V to 27V
DC/DC Out 2P6V	DC/DC LT3010 Enabled through Push Button	2.6V
Power Fail Input Voltage PFI	VIN Threshold, Resistor Divider (R14 + R13) and R12	3.00V
UVLO Monitor Input Voltage	VIN Threshold, Resistor Divider R14 and (R13 + R12)	2.65V
Voltage Monitor VM	Voltage Threshold to VM (2P6V), Resistor Divider R3 and R2	2.33V
Monitor Pins Threshold Voltage	/PFI, VM, UVLO	500mV
UVLO Input Hysteresis	UVLO Pin (Note 1)	30mV
Turn ON Debounce Time	Push Button Turn On	32ms
Turn OFF Debounce Time	JP2 Set to OPEN, Push Button Turn Off	32ms
	JP2 Set to CAP to Connect 0.47uF to PDT Pin (Note 2)	32ms + 3008ms

Note 1: The resistor divider at UVLO sets 2.7V above the UVLO threshold. Supply must first ramp up above 3.0V to exceed the UVLO Input Hysteresis for operation between 2.7V to 3.0V.

Note 2: $0.47\mu\text{F} * (6.4 \text{ seconds} / \mu\text{F}) = 3.008 \text{ seconds}$

QUICK START GUIDE FOR DEMONSTRATION CIRCUIT 1099

PUSH BUTTON ON/OFF CONTROLLER WITH BATTERY AND SUPPLY MONITORING

QUICK START PROCEDURE

Demonstration circuit 1099 is easy to set up to evaluate the performance of the LTC2953. Refer to Figure 1 for proper measurement equipment setup and follow the procedure below.

1. Place jumpers in the following positions:

JP1 UNTIE

JP2 CAP

2. Apply a voltage of 3.0V to 27V across VIN and GND.

3. Push down on Push Button SW1 for a Turn On. 2P6V LED will turn on from the 2.6V output.

4. Push down on Push Button SW1 for over 3 seconds for a turn off. /INT LED will momentarily turn on then turn off along with 2P6V LED.

5. Again, push down on Push Button SW1 for a Turn On.

6. Ramp down supply below 3.0V and no lower than 2.7V. /PFO LED will turn on.

7. Ramp down supply below 2.65V. /INT LED will momentarily turn on, then turn off along with 2P6V LED and /PFO LED.

Additional Tests:

8. Move JP2 to OPEN for a faster Push Button power down time and repeat steps 1 through 8.

9. Move JP1 to TIE for an immediate Push Button shutdown.

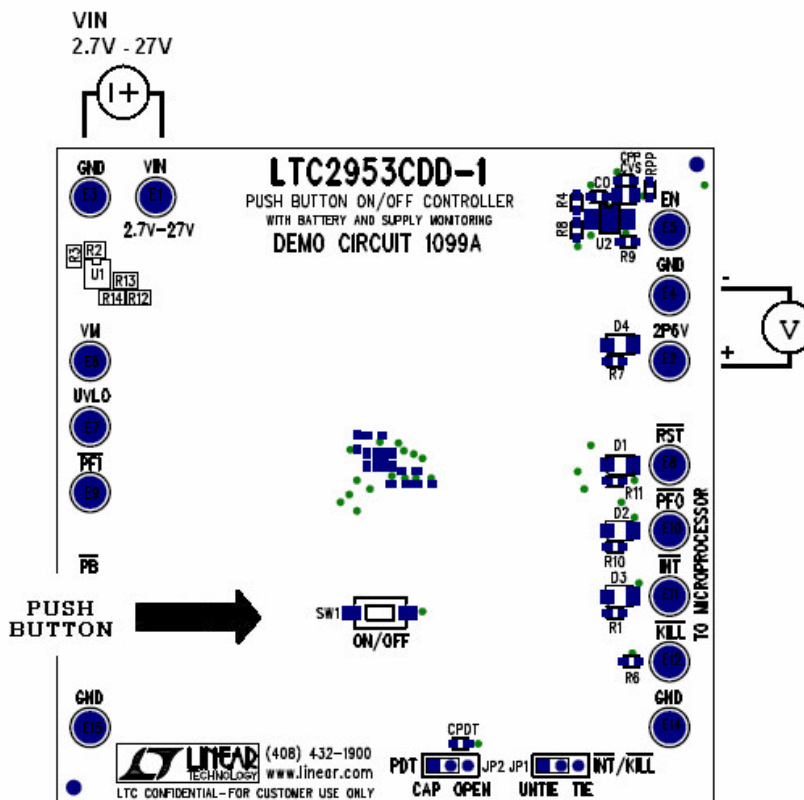
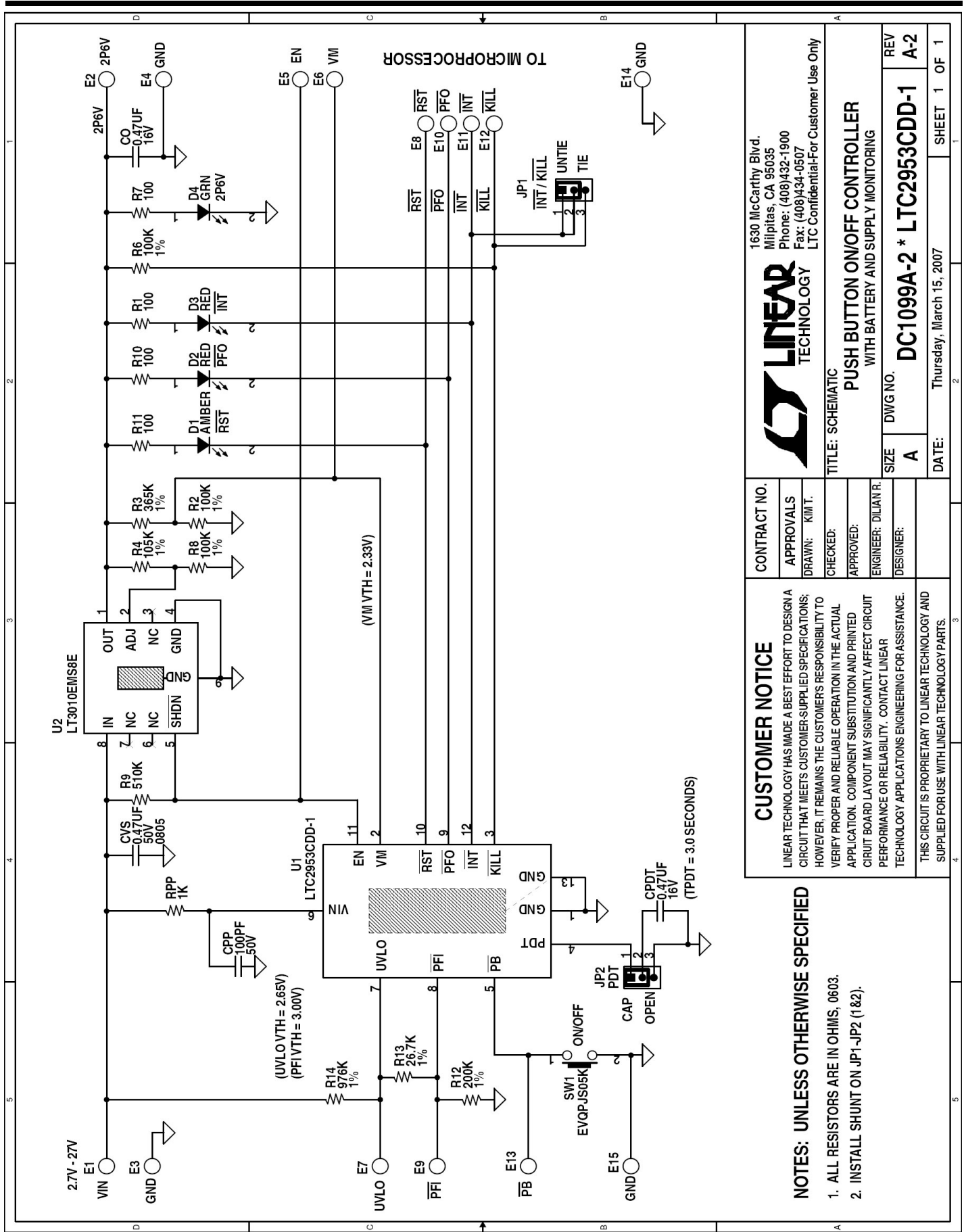

Figure 1. Proper Measurement Equipment Setup

QUICK START GUIDE FOR DEMONSTRATION CIRCUIT 1099

PUSH BUTTON ON/OFF CONTROLLER WITH BATTERY AND SUPPLY MONITORING



LINEAR TECHNOLOGY
 1630 McCarthy Blvd.
 Milpitas, CA 95035
 Phone: (408)432-1900
 Fax: (408)434-0507
 LTC Confidential-For Customer Use Only

TITLE: SCHEMATIC
PUSH BUTTON ON/OFF CONTROLLER
 WITH BATTERY AND SUPPLY MONITORING

CONTRACT NO.
APPROVALS
 DRAWN: KIM T.
 CHECKED:
 APPROVED:
 ENGINEER: DILIAN R.
 DESIGNER:

SIZE A
DWG NO. DC1099A-2 * LTC2953CDD-1
REV A-2

DATE: Thursday, March 15, 2007
SHEET 1 OF 1

CUSTOMER NOTICE

LINEAR TECHNOLOGY HAS MADE A BEST EFFORT TO DESIGN A CIRCUIT THAT MEETS CUSTOMER-SUPPLIED SPECIFICATIONS; HOWEVER, IT REMAINS THE CUSTOMER'S RESPONSIBILITY TO VERIFY PROPER AND RELIABLE OPERATION IN THE ACTUAL APPLICATION. COMPONENT SUBSTITUTION AND PRINTED CIRCUIT BOARD LAYOUT MAY SIGNIFICANTLY AFFECT CIRCUIT PERFORMANCE OR RELIABILITY. CONTACT LINEAR TECHNOLOGY APPLICATIONS ENGINEERING FOR ASSISTANCE.

THIS CIRCUIT IS PROPRIETARY TO LINEAR TECHNOLOGY AND SUPPLIED FOR USE WITH LINEAR TECHNOLOGY PARTS.

- NOTES: UNLESS OTHERWISE SPECIFIED**
1. ALL RESISTORS ARE IN OHMS, 0603.
 2. INSTALL SHUNT ON JP1-JP2 (1&2).

X-ON Electronics

Largest Supplier of Electrical and Electronic Components

Click to view similar products for [Power Management IC Development Tools](#) category:

Click to view products by [Analog Devices](#) manufacturer:

Other Similar products are found below :

[EVAL-ADM1168LQEBZ](#) [EVB-EP5348UI](#) [MIC23451-AAAYFL EV](#) [MIC5281YMME EV](#) [DA9063-EVAL](#) [ADP122-3.3-EVALZ](#) [ADP130-0.8-EVALZ](#) [ADP130-1.2-EVALZ](#) [ADP130-1.5-EVALZ](#) [ADP130-1.8-EVALZ](#) [ADP1714-3.3-EVALZ](#) [ADP1716-2.5-EVALZ](#) [ADP1740-1.5-EVALZ](#) [ADP1752-1.5-EVALZ](#) [ADP1828LC-EVALZ](#) [ADP1870-0.3-EVALZ](#) [ADP1871-0.6-EVALZ](#) [ADP1873-0.6-EVALZ](#) [ADP1874-0.3-EVALZ](#) [ADP1882-1.0-EVALZ](#) [ADP199CB-EVALZ](#) [ADP2102-1.25-EVALZ](#) [ADP2102-1.875EVALZ](#) [ADP2102-1.8-EVALZ](#) [ADP2102-2-EVALZ](#) [ADP2102-3-EVALZ](#) [ADP2102-4-EVALZ](#) [ADP2106-1.8-EVALZ](#) [ADP2147CB-110EVALZ](#) [AS3606-DB](#) [BQ24010EVM](#) [BQ24075TEVM](#) [BQ24155EVM](#) [BQ24157EVM-697](#) [BQ24160EVM-742](#) [BQ24296MEVM-655](#) [BQ25010EVM](#) [BQ3055EVM](#) [NCV891330PD50GEVB](#) [ISLUSBI2CKIT1Z](#) [LM2744EVAL](#) [LM2854EVAL](#) [LM3658SD-AEV/NOPB](#) [LM3658SDEV/NOPB](#) [LM3691TL-1.8EV/NOPB](#) [LM4510SDEV/NOPB](#) [LM5033SD-EVAL](#) [LP38512TS-1.8EV](#) [EVAL-ADM1186-1MBZ](#) [EVAL-ADM1186-2MBZ](#)