

## DESCRIPTION

Demonstration circuit 1105A is a high efficiency synchronous step-down DC/DC converter with output tracking featuring the LTC3822EDD-1 controller. The demo board is capable of providing 1.8V/8A from 2.75V to 4.5V input. Burst mode/Pulse skipping/Forced continuous operation is selectable. The constant frequency current mode architecture with MOSFET  $V_{DS}$  sensing eliminates the need for a sense resistor and improves efficiency. The maximum peak current sense threshold can easily be selected with the IPRG pin.

Switching frequency is internally set at 550KHz. The frequency can be adjusted using PLLLPF pin. Tying

PLLLPF pin to GND selects 300KHz operation; tying PLLLPF pin to  $V_{IN}$  selects 750KHz operation. The switching frequency can also be externally synchronized from 250KHz to 750KHz using SYNC terminal (JP1 should be selected for Sync).

The demo board has a tracking feature, allowing  $V_{out}$  to track an external voltage signal at TRACK terminal (JP2 selected for Track).

**Design files for this circuit board are available. Call the LTC factory.**

 , LTC and LT are registered trademarks of Linear Technology Corporation.

**Table 1. Performance Summary ( $T_A = 25^\circ\text{C}$ )**

PARAMETER	CONDITION	VALUE
Input Voltage Range		2.75V to 4.5V
$V_{OUT}$	$V_{IN} = 2.75\text{-}4.5\text{V}$ , $I_{OUT} = 0\text{A to }8\text{A}$	1.8V $\pm 2\%$
Maximum load current $I_{OUT}$	$V_{IN} = 2.75\text{-}4.5\text{V}$ , $V_{OUT} = 1.8\text{V}$	8A
Typical Output Ripple Voltage	$V_{IN} = 3.3\text{V}$ , $I_{OUT} = 4\text{A}$ , $F_s = 550\text{KHz}$ (20MHz BW)	12mV <sub>P-P</sub>
Typical Switching Frequency	PLLLPF Pin Floating	550kHz

## QUICK START PROCEDURE

Demonstration circuit 1105A is easy to set up to evaluate the performance of the LTC3822-1. Refer to Figure 1 for proper measurement equipment setup and follow the procedure below: (Initial jumper positions: JP1: PS; JP2: Soft Start)

**NOTE:** When measuring the input or output voltage ripple, care must be taken to avoid a long ground lead on the oscilloscope probe. Measure the input or output voltage ripple by touching the probe tip directly across the  $V_{in}$  or  $V_{out}$  and GND terminals. See Figure 2 for proper scope probe technique.

1. With power off, connect the input power supply to +Vin (2.75V-4.5V) and GND (input return).
2. Connect the 1.8V load between  $V_{out}$  and GND (Initial load: 0 A).
3. Connect DVMs to the input and output.
4. Turn on the input power supply and check for the proper output voltage.  $V_{out}$  should be 1.8V $\pm 2\%$ .
5. Once the proper output voltage is established, adjust the load within the operating range and observe the

# QUICK START GUIDE FOR DEMONSTRATION CIRCUIT 1105

## LOW VIN SYNCHRONOUS STEP-DOWN CONVERTER WITH TRACKING

output voltage regulation, ripple voltage and other parameters.

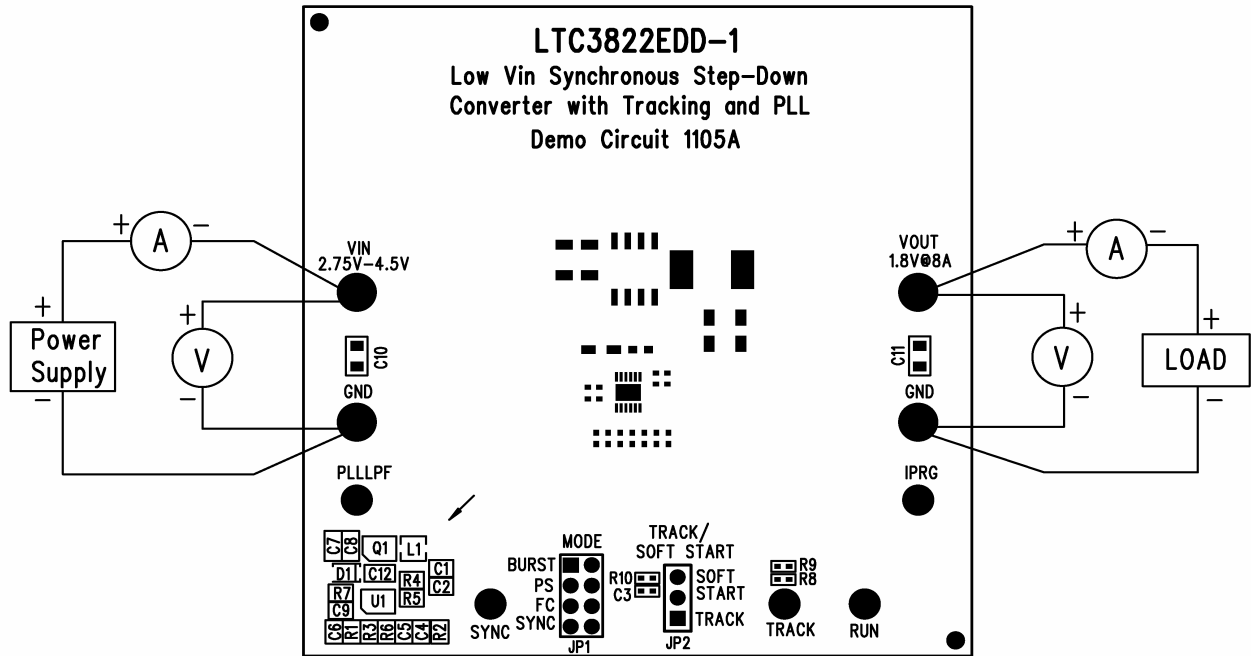

Figure 1. Proper Measurement Equipment Setup

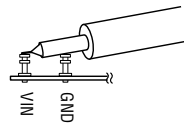

Figure 2. Measuring Input or Output Ripple

# QUICK START GUIDE FOR DEMONSTRATION CIRCUIT 1105

## LOW VIN SYNCHRONOUS STEP-DOWN CONVERTER WITH TRACKING

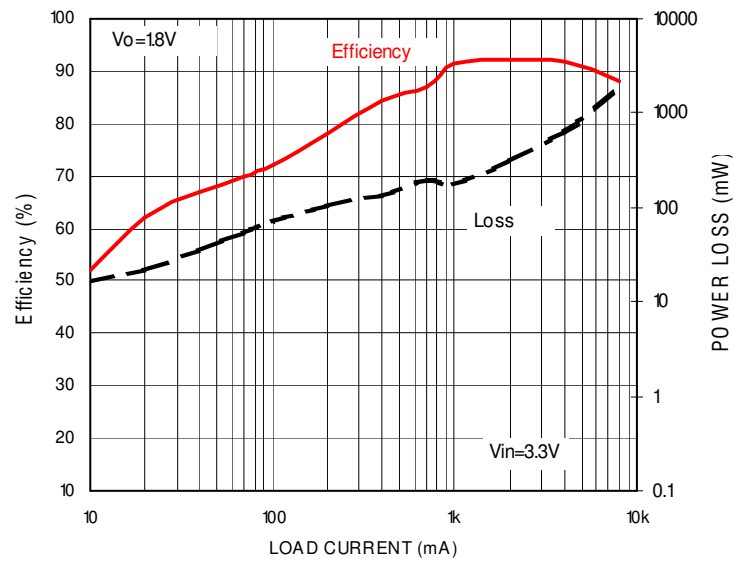
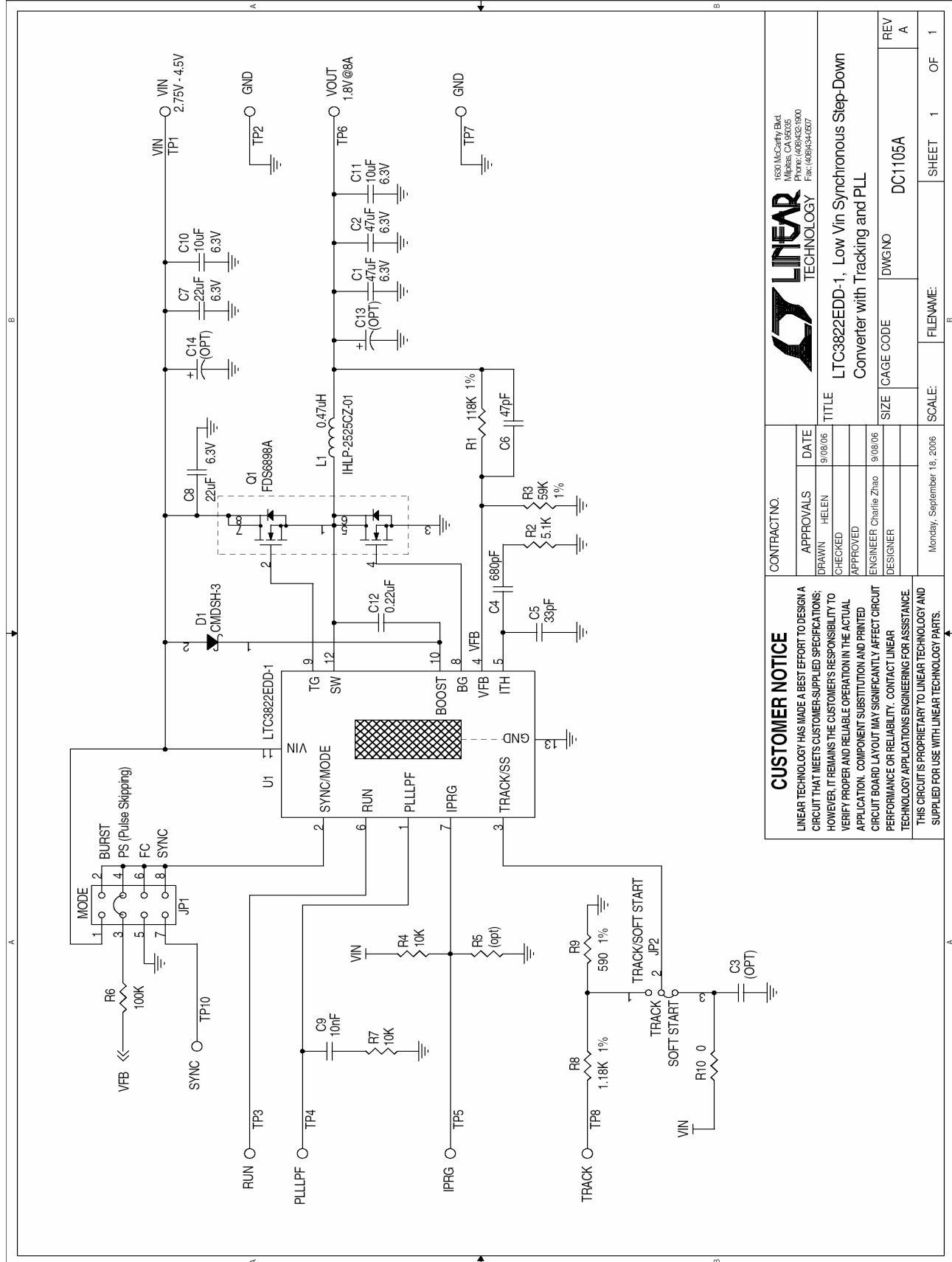

Figure 3. Efficiency and Power Loss vs Load Current (Pulse Skipping, 550KHz)

# QUICK START GUIDE FOR DEMONSTRATION CIRCUIT 1105

## LOW VIN SYNCHRONOUS STEP-DOWN CONVERTER WITH TRACKING



<b>CUSTOMER NOTICE</b>		<b>CONTRACT NO.</b>	
LINEAR TECHNOLOGY HAS MADE A BEST EFFORT TO DESIGN A CIRCUIT THAT MEETS CUSTOMER-SUPPLIED SPECIFICATIONS; HOWEVER, IT REMAINS THE CUSTOMER'S RESPONSIBILITY TO VERIFY PROPER AND RELIABLE OPERATION IN THE ACTUAL APPLICATION. COMPONENT SUBSTITUTION AND PRINTED CIRCUIT BOARD LAYOUT MAY SIGNIFICANTLY AFFECT CIRCUIT PERFORMANCE OR RELIABILITY. CONTACT LINEAR TECHNOLOGY APPLICATIONS ENGINEERING FOR ASSISTANCE. THIS CIRCUIT IS PROPRIETARY TO LINEAR TECHNOLOGY AND SUPPLIED FOR USE WITH LINEAR TECHNOLOGY PARTS.			
APPROVALS	DATE	DESIGNER	SCALE
DRAWN HELEN	9/08/06	Monday, September 18, 2006	1 OF 1
CHECKED		FILENAME:	
APPROVED		SIZE	
ENGINEER Charlie Zhao	9/08/06	CAGE CODE	
		DWG NO	
		REV	
		A	
		DC1105A	
		SHEET	
		1	
		OF	
		1	

1630 McCarty Blvd.  
 Milpitas, CA 95035  
 Phone: (408)422-1600  
 Fax: (408)422-6207

**LINEAR TECHNOLOGY**

TITLE  
 LTC3822EDD-1, Low Vin Synchronous Step-Down Converter with Tracking and PLL

## X-ON Electronics

Largest Supplier of Electrical and Electronic Components

*Click to view similar products for [Power Management IC Development Tools](#) category:*

*Click to view products by [Analog Devices](#) manufacturer:*

Other Similar products are found below :

[EVAL-ADM1168LQEBZ](#) [EVB-EP5348UI](#) [MIC23451-AAAYFL EV](#) [MIC5281YMME EV](#) [DA9063-EVAL](#) [ADP122-3.3-EVALZ](#) [ADP130-0.8-EVALZ](#) [ADP130-1.2-EVALZ](#) [ADP130-1.5-EVALZ](#) [ADP130-1.8-EVALZ](#) [ADP1714-3.3-EVALZ](#) [ADP1716-2.5-EVALZ](#) [ADP1740-1.5-EVALZ](#) [ADP1752-1.5-EVALZ](#) [ADP1828LC-EVALZ](#) [ADP1870-0.3-EVALZ](#) [ADP1871-0.6-EVALZ](#) [ADP1873-0.6-EVALZ](#) [ADP1874-0.3-EVALZ](#) [ADP1882-1.0-EVALZ](#) [ADP199CB-EVALZ](#) [ADP2102-1.25-EVALZ](#) [ADP2102-1.875EVALZ](#) [ADP2102-1.8-EVALZ](#) [ADP2102-2-EVALZ](#) [ADP2102-3-EVALZ](#) [ADP2102-4-EVALZ](#) [ADP2106-1.8-EVALZ](#) [ADP2147CB-110EVALZ](#) [AS3606-DB](#) [BQ24010EVM](#) [BQ24075TEVM](#) [BQ24155EVM](#) [BQ24157EVM-697](#) [BQ24160EVM-742](#) [BQ24296MEVM-655](#) [BQ25010EVM](#) [BQ3055EVM](#) [NCV891330PD50GEVB](#) [ISLUSBI2CKIT1Z](#) [LM2744EVAL](#) [LM2854EVAL](#) [LM3658SD-AEV/NOPB](#) [LM3658SDEV/NOPB](#) [LM3691TL-1.8EV/NOPB](#) [LM4510SDEV/NOPB](#) [LM5033SD-EVAL](#) [LP38512TS-1.8EV](#) [EVAL-ADM1186-1MBZ](#) [EVAL-ADM1186-2MBZ](#)