

DESCRIPTION

Demonstration circuit 1113 is a General Purpose High-Side Current-Sense Amplifier featuring the LTC6102.

This demo board amplifies an on-board current-sense resistor voltage-drop, providing a precision uni-polar output voltage proportional to load current. The demo circuit includes scaling resistors that program the gain of the circuit to 33.3V/V. The LTC6102 is powered from the same supply that the sense resistor is connected to and provides a ground referenced output. The LTC6102 can perform current measurements on supplies ranging from 4V to 60V. Since the output voltage is developed as a controlled current through a load resistance, ground-loop errors can be eliminated by simply locating the load

resistor at the destination point (subsequent signal processing such as A/D conversion). Remote loading can be evaluated by simply removing the on board load resistor (R3).

The key performance characteristics of the LTC6102 and DC1113 are shown in the Performance Summary below.

Design files for this circuit board are available. Call the LTC factory.

LT, LT are registered trademarks of Linear Technology Corporation. Other product names may be trademarks of the companies that manufacture the products.

PERFORMANCE SUMMARY Specifications are at $T_A = 25^\circ\text{C}$

SYMBOL	PARAMETER	CONDITIONS	MIN	TYP	MAX	UNITS
V_{IN}	Monitored Supply Input Range		4	5...48	60	V
V_{MON}	Measurement Output Signal	$I_{OUT} = 10\text{A}$		2.0		V
I_{MON}	Measurement Output Signal (current mode)	$I_{OUT} = 10\text{A}$, R3 removed		400		μA
I_{OUT}	Output Load Current Range	Thermal limit of R_{SENSE}			12	A
I_{INQ}	V_{IN} Quiescent Current	$V_{IN} = 12\text{V}$, $I_{OUT} = 0\text{A}$		230		μA
t_R	V_{MON} step-response time	I_{OUT} step from 0A to 10A		4		μs

OPERATING PRINCIPLES

The LTC6102 operates by amplifying the voltage drop on a sense resistor placed in series with the power source of a load to be monitored. The sense inputs of the amplifier differentially measure the sense-resistor drop to control an internal variable current source that allows translation of the input information to a level referenced to V^- (ground in this demo circuit). The circuit gain is established by the ratio of the output resistor to the input re-

sistor and is essentially as accurate as the resistors used. In DC1113 as shipped, the sense resistor installed is $6\text{m}\Omega$ and the resistor ratio sets the gain to 33.3V/V, so the nominal output scaling is 200mV per Ampere of load current. Other scaling can be produced by resistor replacement on the demo circuit.

The DC1113 Schematic diagram is shown in Figure 2.

QUICK START PROCEDURE

Demonstration circuit 1113 is easy to set up to evaluate the performance of the LTC6102. Refer to Figure 1 for proper measurement equipment setup and follow the procedure below:

1. With power off, connect the power supply positive to IN and the common to GND. This supply should be in the range of 4V to 60V. If this supply is not equipped with an accurate current readout, a DMM (set to measure Amperes) may be connected in series with the supply as shown in Figure 1.

NOTE. Be sure that the current capacity of the DMM is adequate to handle the intended load current.

2. Connect a voltmeter or oscilloscope probe to the MON terminal, with the common connection or ground clip tied to GND.
3. Connect a load to the OUT terminal (positive) and return (negative) to the common of the power supply. The load may be a power resistor, active load instrument, or other circuit of interest.
4. Turn on the power supply.
5. Measure an output voltage that corresponds to the load current. $V_{MON} = 0.2 \times I_{OUT}$ for the factory installed resistors.

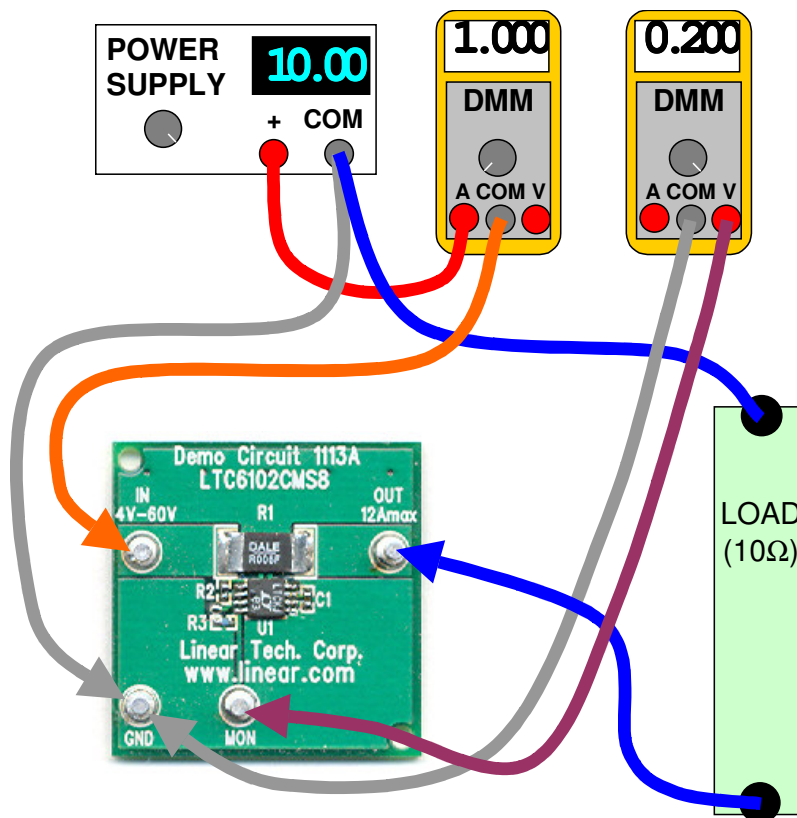

Figure 1. Proper Measurement Equipment Setup

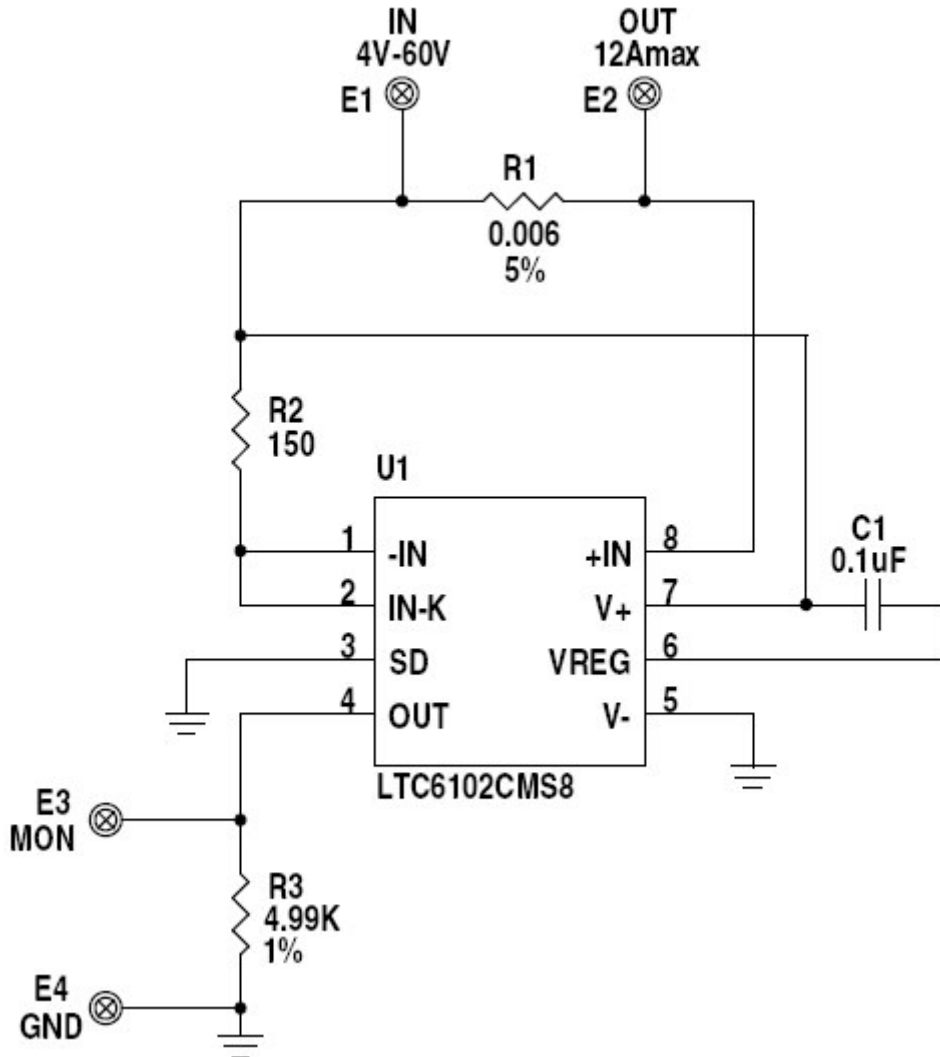

Figure 2. DC1113 Schematic Diagram

X-ON Electronics

Largest Supplier of Electrical and Electronic Components

Click to view similar products for [Amplifier IC Development Tools](#) category:

Click to view products by [Analog Devices](#) manufacturer:

Other Similar products are found below :

[EVAL-ADCMP566BCPZ](#) [EVAL-ADCMP606BKSZ](#) [AD8013AR-14-EBZ](#) [AD8033AKS-EBZ](#) [AD8044AR-EBZ](#) [AD8225-EVALZ](#)
[ADA4859-3ACP-EBZ](#) [ADA4862-3YR-EBZ](#) [DEM-OPA-SO-2B](#) [AD744JR-EBZ](#) [AD8023AR-EBZ](#) [AD8030ARJ-EBZ](#) [AD8040ARU-EBZ](#)
[AD8073JR-EBZ](#) [AD813AR-14-EBZ](#) [AD848JR-EBZ](#) [ADA4858-3ACP-EBZ](#) [ADA4922-1ACP-EBZ](#) [551600075-001/NOPB](#) [DEM-OPA-SO-](#)
[2E](#) [THS7374EVM](#) [EVAL-ADCMP553BRMZ](#) [EVAL-ADCMP608BKSZ](#) [MIOP 42109](#) [EVAL-ADCMP609BRMZ](#) [MAX9928EVKIT+](#)
[MAX9636EVKIT+](#) [MAX9611EVKIT](#) [MAX9937EVKIT+](#) [MAX9934TEVKIT+](#) [MAX44290EVKIT#](#) [MAX2644EVKIT](#) [MAX2634EVKIT](#)
[MAX4073EVKIT+](#) [DEM-OPA-SO-2C](#) [ISL28158EVAL1Z](#) [MAX40003EVKIT#](#) [MAX2473EVKIT](#) [MAX2472EVKIT](#) [MAX4223EVKIT](#)
[MAX9700BEVKIT](#) [MADL-011014-001SMB](#) [DC1685A](#) [DEM-OPA-SO-2D](#) [MAX2670EVKIT#](#) [DEM-OPA-SO-1E](#) [AD8137YCP-EBZ](#)
[EVAL-ADA4523-1ARMZ](#) [MAX44242EVKIT#](#) [EVAL-LT5401_32FDAZ](#)