

# LTC6103

## Dual, High Voltage, High Side Current Sense Amplifier

### DESCRIPTION

Demonstration Circuit 1116 is a Dual, High Voltage, High Side Current Sense Amplifier featuring the LTC6103.

This demo board provides two independent circuits that each amplify a current-sense resistor voltage-drop, and provide precision uni-polar output voltages proportional to the respective load currents. The demo circuit includes scaling resistors that program the gain of the circuits to 25V/V. Each section of the LTC6103 is powered from the same supply that the sense resistor is connected to and provides a ground referenced output. Each section of the LTC6103 can independently perform current measurements on supplies ranging from 4V to 60V. Since the output voltages are developed as controlled

currents through load resistances, ground-loop errors can be eliminated by simply locating the load resistors at the destination point (subsequent signal processing such as A/D conversion). Remote loading can be evaluated by simply removing the on board load resistors (R3 and R6).

The key performance characteristics of the LTC6103 and DC1116 are shown in the Performance Summary below.

**Design files for this circuit board are available. Call the LTC factory.**

LT, LT, Over-The-Top are registered trademarks of Linear Technology Corporation. Other product names may be trademarks of the companies that manufacture the products.

### PERFORMANCE SUMMARY Specifications are at T<sub>R</sub> = 25°C

SYMBOL	PARAMETER	CONDITIONS	MIN	TYP	MAX	UNITS
V <sub>INA</sub> , V <sub>INB</sub>	Monitored Supply Input Range		4	5...48	60	V
V <sub>MonA</sub>	Measurement Output Signal	I <sub>OUTA</sub> = 5A		2.5		V
V <sub>MonB</sub>	Measurement Output Signal	I <sub>OUTB</sub> = 5A		2.5		V
I <sub>MonA</sub>	Measurement Output Signal (current mode)	I <sub>OUTA</sub> = 5A, R3 removed		500		μA
I <sub>MonB</sub>	Measurement Output Signal (current mode)	I <sub>OUTB</sub> = 5A, R6 removed		500		μA
I <sub>OUTA</sub> , I <sub>OUTB</sub>	Output Load Current Range	Thermal limit of R <sub>SENSE</sub> (R1 or R4)			7	A
I <sub>INAQ</sub>	V <sub>INA</sub> Quiescent Current	V <sub>INA</sub> = 12V, I <sub>OUTA</sub> = 0A		250		μA
I <sub>INBQ</sub>	V <sub>INB</sub> Quiescent Current	V <sub>INB</sub> = 12V, I <sub>OUTB</sub> = 0A		250		μA
t <sub>R</sub>	V <sub>MonA</sub> or V <sub>MonB</sub> step-response time	I <sub>OUTA</sub> or I <sub>OUTB</sub> step from 0A to 5A		2		μs

### OPERATING PRINCIPLES

The LTC6103 operates by amplifying the voltage drop on a sense resistor placed in series with the power source of a load to be monitored. The sense inputs of the amplifier differentially measure the sense-resistor drop to control an internal variable current source that allows translation of the input information to a level referenced to V<sub>EE</sub> (ground in this demo circuit). The LTC6103 provides two

identical sense amplifiers in one package. In DC1116 as shipped, the sense resistors installed are 20mΩ and the other resistors program the gains to 25V/V, so the nominal output scalings are 500mV per ampere of load current. Other scalings can be realized by making resistor changes on the demo circuit.

The DC1116 Schematic diagram is shown in Figure 2.

## QUICK START PROCEDURE

Demonstration circuit 1116 is easy to set up to evaluate the performance of the LTC6103. Refer to Figure 1 for proper measurement equipment setup and follow the procedure below:

**NOTE.** Each section of the LTC6103 may be powered (or not) independently.

1. With power off, connect a power supply positive to INA and the common to GND. This supply should be in the range of 4V to 60V. If this supply is not equipped with an accurate current readout, a DMM (set to measure Amperes) may be connected in series with the supply.

**NOTE.** Be sure that the capacity of a current measuring DMM is adequate to handle the intended load current.

2. Connect a voltmeter or oscilloscope probe to the MonA terminal, with the common connection or ground clip tied to GND.
3. Connect a load to the OUTA terminal (positive) and return (negative) to the common of the power supply.

4. Turn on the power supply.
5. Measure an output voltage that corresponds to the load current.  $V_{\text{MonA}} = 0.5 \times I_{\text{OUT}}$  for the factory installed resistors.
6. With power off, connect a second power supply positive to INB and the common to GND. This supply should be in the range of 4V to 60V.
7. Connect a second voltmeter or oscilloscope probe to the MonB terminal, with the common connection or ground clip tied to GND.
8. Connect a second load to the OUTB terminal (positive) and return (negative) to the common of the second power supply.
9. Turn on the second power supply.
10. Measure an output voltage that corresponds to the second load current.  $V_{\text{MonB}} = 0.5 \times I_{\text{OUT}}$  for the factory installed resistors.

**NOTE.** A differential measurement between MonA and MonB will reflect the difference in load current in the two paths. This is useful in measuring load current in H-bridge applications.

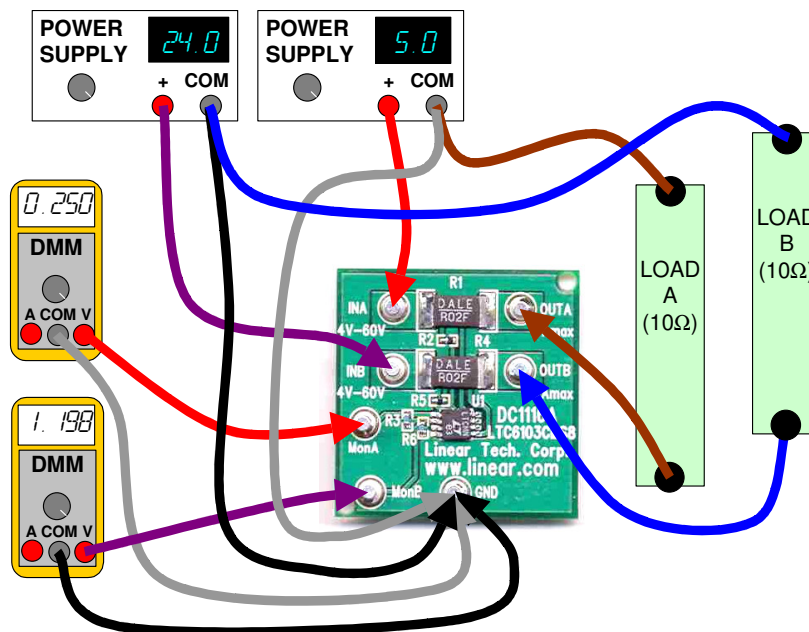

Figure 1. Proper Measurement Equipment Setup

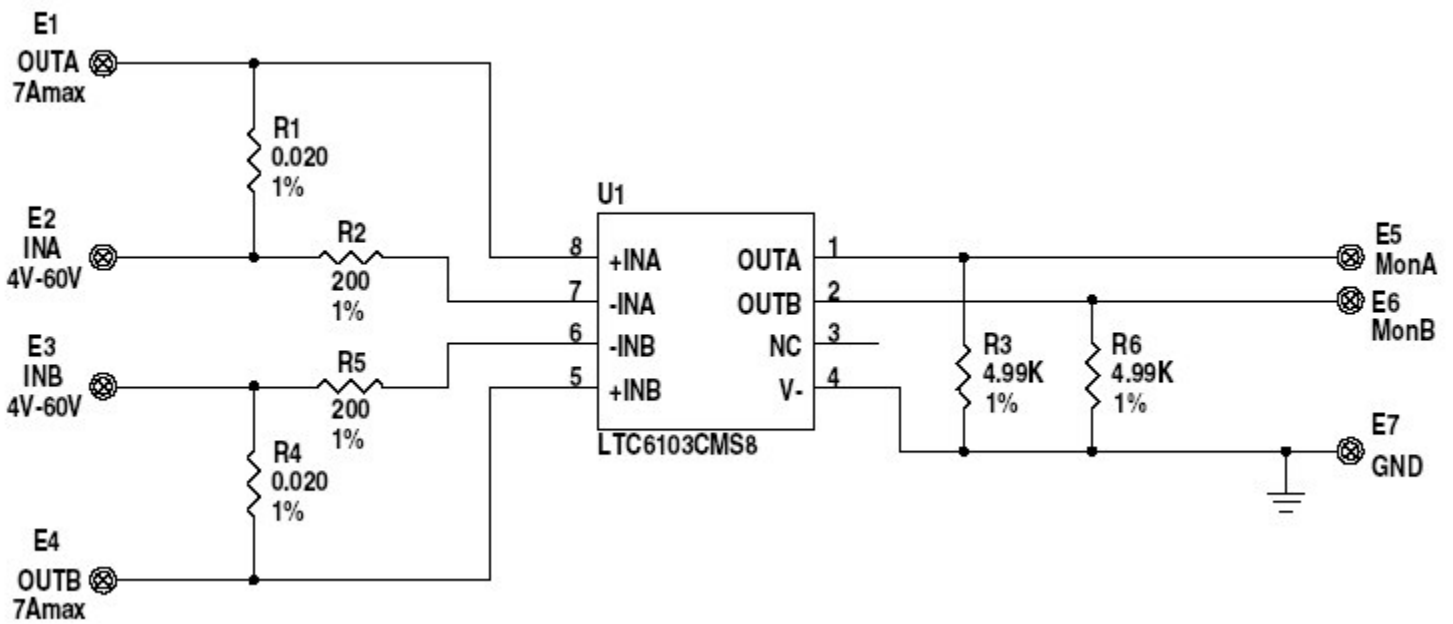

Figure 2. DC1116 Schematic Diagram

## X-ON Electronics

Largest Supplier of Electrical and Electronic Components

*Click to view similar products for [Amplifier IC Development Tools](#) category:*

*Click to view products by [Analog Devices](#) manufacturer:*

Other Similar products are found below :

[EVAL-ADCMP566BCPZ](#) [EVAL-ADCMP606BKSZ](#) [AD8013AR-14-EBZ](#) [AD8033AKS-EBZ](#) [AD8044AR-EBZ](#) [AD8225-EVALZ](#)  
[ADA4859-3ACP-EBZ](#) [ADA4862-3YR-EBZ](#) [DEM-OPA-SO-2B](#) [AD744JR-EBZ](#) [AD8023AR-EBZ](#) [AD8030ARJ-EBZ](#) [AD8040ARU-EBZ](#)  
[AD8073JR-EBZ](#) [AD813AR-14-EBZ](#) [AD848JR-EBZ](#) [ADA4858-3ACP-EBZ](#) [ADA4922-1ACP-EBZ](#) [551600075-001/NOPB](#) [DEM-OPA-SO-](#)  
[2E](#) [THS7374EVM](#) [EVAL-ADCMP553BRMZ](#) [EVAL-ADCMP608BKSZ](#) [MIOP 42109](#) [EVAL-ADCMP609BRMZ](#) [MAX9928EVKIT+](#)  
[MAX9636EVKIT+](#) [MAX9611EVKIT](#) [MAX9937EVKIT+](#) [MAX9934TEVKIT+](#) [MAX44290EVKIT#](#) [MAX2644EVKIT](#) [MAX4073EVKIT+](#)  
[DEM-OPA-SO-2C](#) [MAX2643EVKIT](#) [ISL28158EVAL1Z](#) [MAX40003EVKIT#](#) [MAX2473EVKIT](#) [MAX2472EVKIT](#) [MAX4223EVKIT](#)  
[MAX9700BEVKIT](#) [MADL-011014-001SMB](#) [DC1685A](#) [DEM-OPA-SO-2D](#) [MAX2670EVKIT#](#) [DEM-OPA-SO-1E](#) [AD8137YCP-EBZ](#)  
[EVAL-ADA4523-1ARMZ](#) [MAX44242EVKIT#](#) [EVAL-LT5401\\_32FDAZ](#)