

DESCRIPTION

Demonstration circuit 1120A is a wide dynamic range RF power detector featuring the LT[®]5538.

The LT5538 is a 40MHz to 3.8GHz monolithic logarithmic RF power detector capable of measuring RF signals from -75dBm to 10dBm . The RF signal in a decibel scale is precisely converted into DC voltage on a linear scale. The wide input dynamic range is achieved using cascaded RF detectors and RF limiters. Their outputs are summed to generate an accurate linear DC voltage proportional to the input RF signal in dBm. The output is buffered with a low impedance driver. The LT5538 delivers superior temperature stable output (within $\pm 1\text{dB}$ over full temperature range) from 40MHz to 3.8GHz.

Demonstration circuit 1120A features broadband input impedance matching optimized for evaluating the LT5538 at frequencies between 40MHz and 2.7GHz. It can be easily reconfigured for higher operating frequencies up to 3.8GHz or optimized to specific frequencies for narrow band applications. Refer to the “Application Note” section and the LT5538 data sheet for details.

Design files for this circuit board are available. Call the LTC factory.

 , LT, LTC, and LTM are registered trademarks of Linear Technology Corp. All other trademarks are the property of their respective owners.

Table 1. Typical Demo Circuit Performance Summary ($V_{CC} = 5\text{V}$, $EN = 5\text{V}$, $T_A = 25^\circ\text{C}$, source impedance = 50Ω , unless otherwise noted. Test circuit shown in Figure 2.)

PARAMETER	CONDITION	VALUE
RF Input Frequency Range	Standard Demonstration Circuit 1120A, $>10\text{dB}$ Return Loss (Can be re-matched up to 3.8GHz, refer to the “Application Note”)	40MHz to 2.7GHz
Supply Voltage		3V to 5.25V
Supply Current		29mA
Shutdown Current	EN = Low	1 μA
EN = High (On)		$> 1\text{V}$
EN = Low (Off)		$< 0.3\text{V}$
Turn On Time		300ns
Turn Off Time		1 μs
Output DC voltage	No RF Input Signal Present	350mV
Output Impedance		150 Ω
Output Source Current		10mA
Output Sink Current		200 μA
Rise Time	0.5V to 1.6V, 10% to 90%, $f_{RF} = 880\text{MHz}$	100ns
Fall Time	1.6V to 0.5V, 10% to 90%, $f_{RF} = 880\text{MHz}$	180ns

QUICK START GUIDE FOR DEMONSTRATION CIRCUIT 1120A

40MHZ TO 3.8GHZ RF POWER DETECTOR WITH 75dB DYNAMIC RANGE

Table 2. Typical Demo Circuit Performance Summary, continued ($V_{CC} = 5V$, $EN = 5V$, $T_A = 25^\circ C$, source impedance = 50Ω , unless otherwise noted. Test circuit shown in Figure 2.)

PARAMETER	CONDITION	VALUE
$f_{RF} = 40MHz$		
RF Input Power Range		-75dBm to 10dBm
Linear Dynamic Range	$\pm 1dB$ Linearity Error	76dB
Output Slope		19.9mV/dB
Logarithmic Intercept		-87.5dBm
Sensitivity		-72dBm
$f_{RF} = 450MHz$		
RF Input Power Range		-75dBm to 10dBm
Linear Dynamic Range	$\pm 1dB$ Linearity Error	75dB
Output Slope		19.6mV/dB
Logarithmic Intercept		-87.3dBm
Sensitivity		-71.5dBm
$f_{RF} = 880MHz$		
RF Input Power Range		-75dBm to 10dBm
Linear Dynamic Range	$\pm 1dB$ Linearity Error	75dB
Output Slope		19.0mV/dB
Logarithmic Intercept		-88.8dBm
Sensitivity		-71.5dBm
$f_{RF} = 2140MHz$		
RF Input Power Range		-72dBm to 10dBm
Linear Dynamic Range	$\pm 1dB$ Linearity Error	70dB
Output Slope		17.7mV/dB
Logarithmic Intercept		-89.0dBm
Sensitivity		-69.0dBm
$f_{RF} = 2700MHz$		
RF Input Power Range		-72dBm to 10dBm
Linear Dynamic Range	$\pm 1dB$ Linearity Error	65dB
Output Slope		17.6mV/dB
Logarithmic Intercept		-87.5dBm
Sensitivity		-69.5dBm
$f_{RF} = 3600MHz$		
RF Input Power Range		-65dBm to 10dBm
Linear Dynamic Range	$\pm 1dB$ Linearity Error	57dB
Output Slope		18mV/dB
Logarithmic Intercept		-81.4dBm
Sensitivity		-63dBm

QUICK START GUIDE FOR DEMONSTRATION CIRCUIT 1120A

40MHZ TO 3.8GHZ RF POWER DETECTOR WITH 75dB DYNAMIC RANGE

APPLICATION NOTE

ABSOLUTE MAXIMUM RATINGS

Power Supply Voltage5.5V
 Enable Voltage..... -0.3V, $V_{CC} + 0.3V$
 RF Input Power..... 15dBm
 Operating Ambient Temperature-40°C to +85°C
 Storage Temperature Range .. -65°C to +125°C
 Maximum Junction Temperature 150°C

RF INPUT INTERFACE

The standard demonstration circuit 1120A is configured for broadband RF input to ease evaluations at various frequencies. However, it can be easily reconfigured for narrowband operations, which offers slightly improved sensitivity and some frequency selectivity. Examples of some common RF input frequency matching are presented in Table 3. Please refer to circuit schematic in Figure 4. Their return loss plots are shown in Figure 1 and Figure 2.

Table 3. RF Input Matching Component Values

RF Input (MHz)	C8 (*1)	L1 (*1)	C4	C5 (*2)	10dB RL Range (MHz)	Trace No.
40-2700	1pF	1.5nH	1nF	1nF	0.3-2700	1
40-1300	-	0Ω	1nF	1nF	0.3-1300	2
600	27nH	27pF	100pF	100pF	300-1300	3
900	12nH	12pF	100pF	100pF	600-1450	4
1900	2.7nH	3.3pF	22pF	-	1700-2100	5
2140	2.2nH	2.7pF	22pF	-	1900-2300	6
2600	1.5nH	1.5pF	22pF	-	2500-2800	7
3600	0.7pF	3.3pF	22pF	-	3300-3900	8

NOTE:

1. Depending on the operating frequency, C8 can be either a capacitor or an inductor. Similarly, L1 can also be a capacitor, an inductor, or a zero-ohm jumper.
2. The LT5538 IC's IN⁻ pin (Pin 3) is coupled to ground via an internal 20pF capacitor. At low input frequencies, a large value external ac-decoupling capacitor (C5) should be used. At high frequencies, the internal capacitor is sufficient, and C5 can be left open.

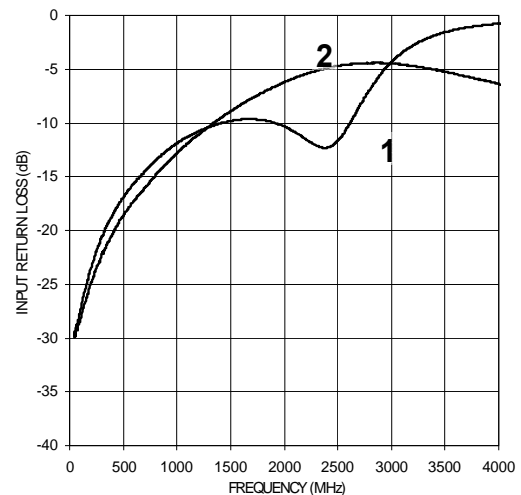

Figure 1. RF Input Return Loss for Wideband Matching

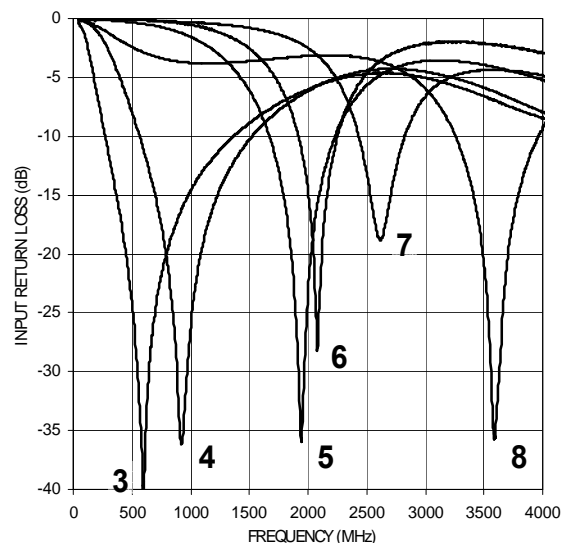

Figure 2. RF Input Return Loss for Narrowband Matching

QUICK START PROCEDURE

Demonstration circuit 1120A is easy to set up to evaluate the performance of the LT5538. Refer to Figure 3 for proper measurement equipment setup and follow the procedure below:

NOTE: Care should be taken to never exceed absolute maximum input ratings. Never apply DC power to EN pin before VCC pin.

1. Connect DC power supply negative (-) output to demo board GND pin.
2. Connect DC power supply positive (+) output (3V to 5.25V) to demo board VCC pin.
3. Connect voltmeter negative (-) lead to demo board GND pin.
4. Connect voltmeter positive (+) lead to the demo board OUT pin.
5. Connect RF signal generator output to demo board RFin port (SMA connector J1) via co-axial cable.
6. Using a jumper cable, connect demo board VCC pin to EN pin. Now the detector is enabled (on) and is ready for measurement.
7. Apply an RF input signal and measure output DC voltage.
8. The linearity dynamic range is defined as the range over which the linearity error is within $\pm 1\text{dB}$. The linearity error is calculated by the difference between the incremental slope of the output and the average output slope from -50dBm to -20dBm .
9. Sensitivity is defined as the minimum input power required for the linearity error to be within 3dB of the ideal log-linear transfer curve.

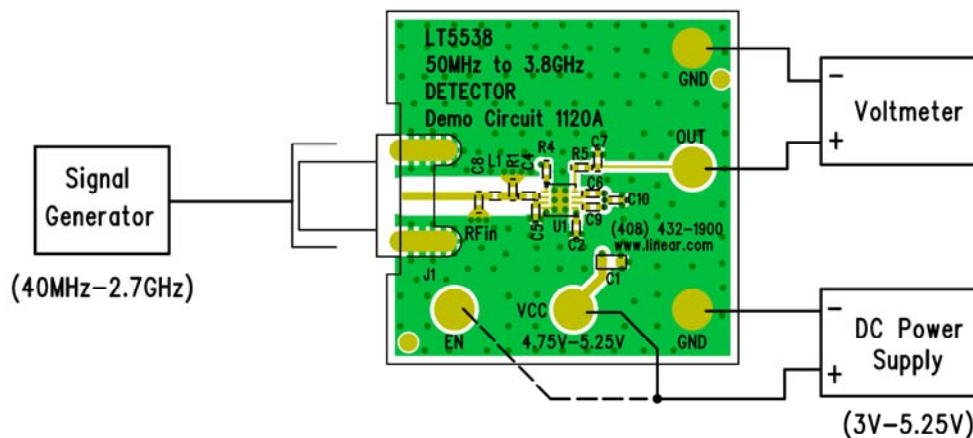
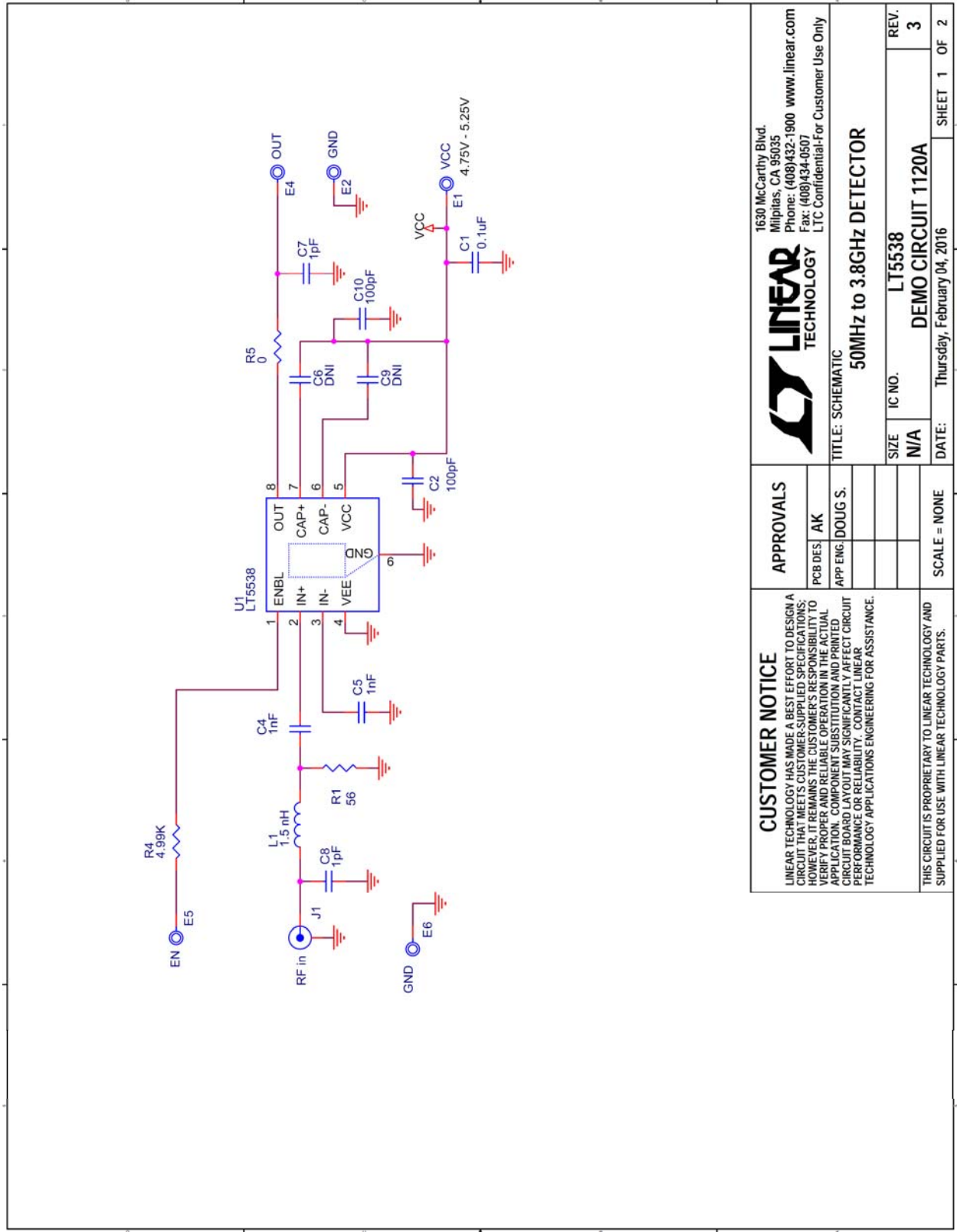

Figure 3. Proper Measurement Equipment Setup

Figure 4. Demonstration Circuit Schematic

QUICK START GUIDE FOR DEMONSTRATION CIRCUIT 1120A

40MHZ TO 3.8GHZ RF POWER DETECTOR WITH 75dB DYNAMIC RANGE



X-ON Electronics

Largest Supplier of Electrical and Electronic Components

Click to view similar products for [RF Development Tools](#) category:

Click to view products by [Analog Devices](#) manufacturer:

Other Similar products are found below :

[MAAM-011117](#) [MAAP-015036-DIEEV2](#) [EV1HMC1113LP5](#) [EV1HMC6146BLC5A](#) [EV1HMC637ALP5](#) [EVAL-ADG919EBZ](#) [ADL5363-EVALZ](#) [LMV228SDEVAL](#) [SKYA21001-EVB](#) [SMP1331-085-EVB](#) [EV1HMC618ALP3](#) [EVAL01-HMC1041LC4](#) [MAAL-011111-000SMB](#) [MAAM-009633-001SMB](#) [MASW-000936-001SMB](#) [107712-HMC369LP3](#) [107780-HMC322ALP4](#) [SP000416870](#) [EV1HMC470ALP3](#) [EV1HMC520ALC4](#) [EV1HMC244AG16](#) [MAX2614EVKIT#](#) [124694-HMC742ALP5](#) [SC20ASATEA-8GB-STD](#) [MAX2837EVKIT+](#) [MAX2612EVKIT#](#) [MAX2692EVKIT#](#) [EV1HMC629ALP4E](#) [SKY12343-364LF-EVB](#) [108703-HMC452QS16G](#) [EV1HMC863ALC4](#) [119197-HMC658LP2](#) [EV1HMC647ALP6](#) [ADL5725-EVALZ](#) [106815-HMC441LM1](#) [EV1HMC1018ALP4](#) [UXN14M9PE](#) [MAX2016EVKIT](#) [EV1HMC939ALP4](#) [MAX2410EVKIT](#) [MAX2204EVKIT+](#) [EV1HMC8073LP3D](#) [SIMSA868-DKL](#) [SIMSA868C-DKL](#) [SKY65806-636EK1](#) [SKY68020-11EK1](#) [SKY67159-396EK1](#) [SKY66181-11-EK1](#) [SKY65804-696EK1](#) [SKY13396-397LF-EVB](#)