

## DESCRIPTION

Demonstration circuit 1122 features LT3681 in a 500kHz step-down converter circuit, designed for 3.3V output from a 4.5V to 34V input. The wide input range of the LT3681 allows a variety of input sources. The typical sources are automotive batteries, wall adaptors and industrial supplies. The current mode control scheme creates fast transient response and good loop stability. In addition, the LT3681's integrated boost diode and catch diode reduce the parts count. The low ripple Burst Mode Operation of LT3681 not only allows the circuit to have high efficiency over a broad current range but also provides the low output ripple at light load conditions. The RUN/SS pin can be used to set the part in

micropower shutdown mode. The RUN/SS pin can also be used to program soft start. In this mode, the RUN/SS pin is driven through an external RC filter to create a voltage ramp on this pin. The soft start function reduces the input current surge during start-up.

The LT3681 datasheet gives a complete description of the part, operation and application information. The datasheet must be read in conjunction with this quick start guide for demo circuit 1122.

**Design files for this circuit board are available. Call the LTC factory.**

LT, LTC and LT are registered trademarks of Linear Technology Corporation. ThinSOT and PowerPath are trademarks of Linear Technology Corporation.

### Performance Summary for Step-Down Regulator ( $T_A = 25^\circ\text{C}$ )

PARAMETER FOR BUCK REGULATOR	CONDITION	VALUE
Minimum Input Voltage		4.5V
Maximum Input Voltage		34V
Output Voltage $V_{\text{OUT}}$		3.3V +/- 4%
Maximum Output Current		2A
Typical Switching Frequency		500kHz

## QUICK START PROCEDURE

Demonstration circuit 1122 is easy to set up to evaluate the performance of the LT3681. Refer to Figure 1 for proper measurement

equipment setup and follow the procedure below:

# LT3681

NOTE. When measuring the input or output voltage ripple, care must be taken to avoid a long ground lead on the oscilloscope probe. Measure the input or output voltage ripple by touching the probe tip directly across the Vin or Vout and GND terminals. See Figure 2 for proper scope probe technique.

1. Place JP1 on the RUN position:
2. With power off, connect the input power supply to Vin and GND.
3. Turn on the power at the input.

NOTE. Make sure that the input voltage does not exceed the maximum input voltage.

4. Check for the proper output voltages.

NOTE. If there is no output, temporarily disconnect the load to make sure that the load is not set too high.

5. Once the proper output voltage is established, adjust the load within the operating range and observe the output voltage regulation, ripple voltage, efficiency and other parameters.

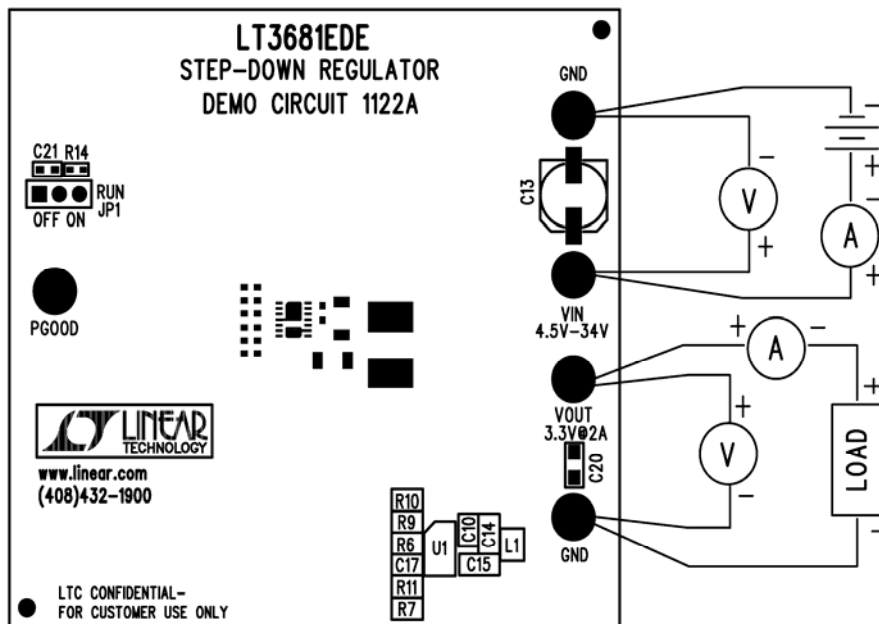

Figure 1. Proper Measurement Equipment Setup

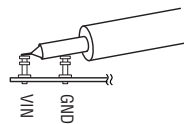
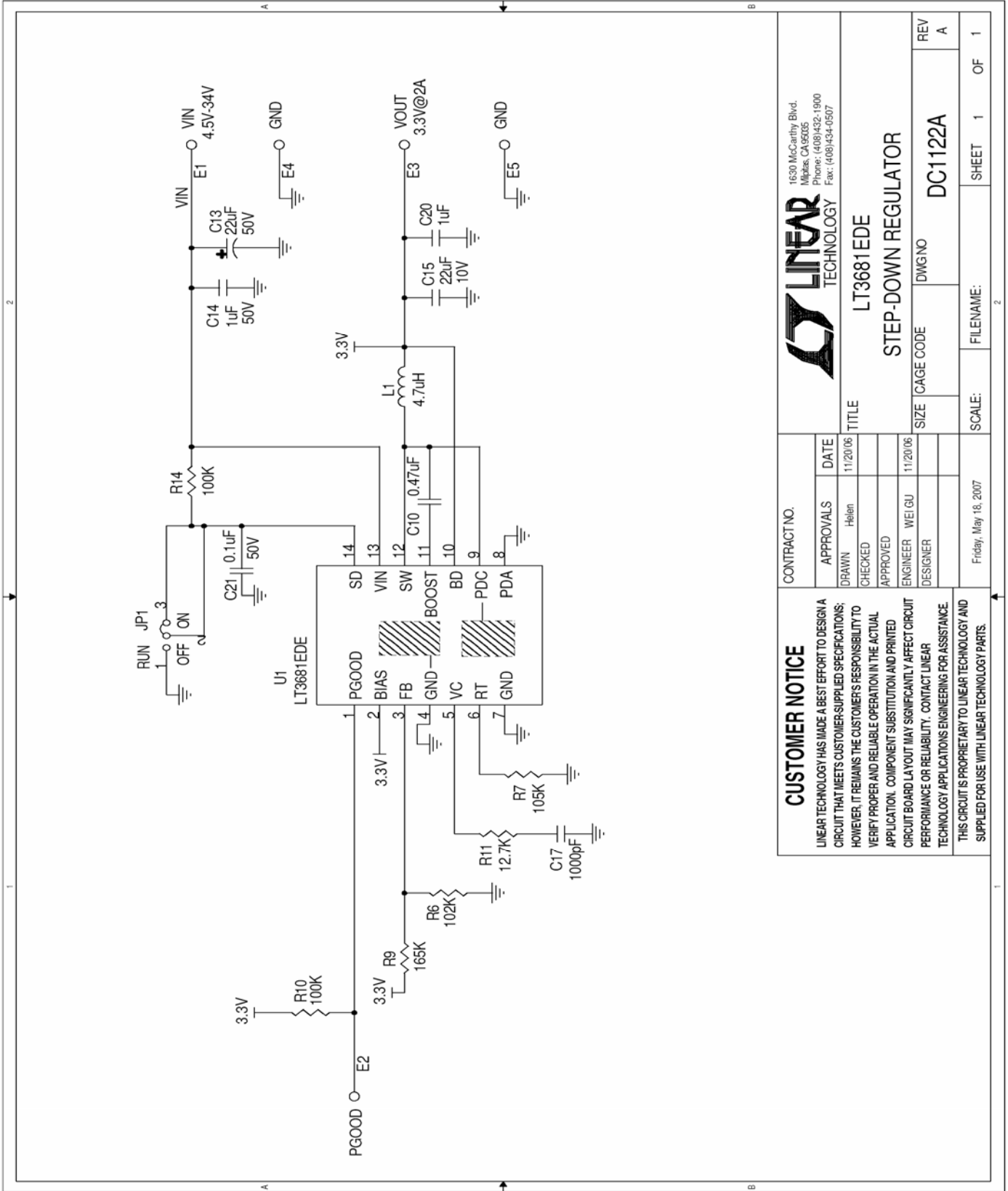

Figure 2. Measuring Input or Output Ripple



<b>CUSTOMER NOTICE</b>		CONTRACT NO.	
LINEAR TECHNOLOGY HAS MADE A BEST EFFORT TO DESIGN A CIRCUIT THAT MEETS CUSTOMER-SUPPLIED SPECIFICATIONS; HOWEVER, IT REMAINS THE CUSTOMER'S RESPONSIBILITY TO VERIFY PROPER AND RELIABLE OPERATION IN THE ACTUAL APPLICATION. COMPONENT SUBSTITUTION AND PRINTED CIRCUIT BOARD LAYOUT MAY SIGNIFICANTLY AFFECT CIRCUIT PERFORMANCE OR RELIABILITY. CONTACT LINEAR TECHNOLOGY APPLICATIONS ENGINEERING FOR ASSISTANCE. THIS CIRCUIT IS PROPRIETARY TO LINEAR TECHNOLOGY AND SUPPLIED FOR USE WITH LINEAR TECHNOLOGY PARTS.			
APPROVALS	DATE	TITLE	
DRAWN: Helen	11/20/06	LT3681EDE	
CHECKED:		STEP-DOWN REGULATOR	
APPROVED:		SIZE	DWG NO
ENGINEER: WET GU	11/20/06		DC1122A
DESIGNER:			REV A
Friday, May 18, 2007	SCALE:	FILENAME:	SHEET 1 OF 1

## X-ON Electronics

Largest Supplier of Electrical and Electronic Components

*Click to view similar products for [Power Management IC Development Tools](#) category:*

*Click to view products by [Analog Devices](#) manufacturer:*

Other Similar products are found below :

[EVAL-ADM1168LQEBZ](#) [EVB-EP5348UI](#) [MIC23451-AAAYFL EV](#) [MIC5281YMME EV](#) [DA9063-EVAL](#) [ADP122-3.3-EVALZ](#) [ADP130-0.8-EVALZ](#) [ADP130-1.2-EVALZ](#) [ADP130-1.5-EVALZ](#) [ADP130-1.8-EVALZ](#) [ADP1714-3.3-EVALZ](#) [ADP1716-2.5-EVALZ](#) [ADP1740-1.5-EVALZ](#) [ADP1752-1.5-EVALZ](#) [ADP1828LC-EVALZ](#) [ADP1870-0.3-EVALZ](#) [ADP1871-0.6-EVALZ](#) [ADP1873-0.6-EVALZ](#) [ADP1874-0.3-EVALZ](#) [ADP1882-1.0-EVALZ](#) [ADP199CB-EVALZ](#) [ADP2102-1.25-EVALZ](#) [ADP2102-1.875EVALZ](#) [ADP2102-1.8-EVALZ](#) [ADP2102-2-EVALZ](#) [ADP2102-3-EVALZ](#) [ADP2102-4-EVALZ](#) [ADP2106-1.8-EVALZ](#) [ADP2147CB-110EVALZ](#) [AS3606-DB](#) [BQ24010EVM](#) [BQ24075TEVM](#) [BQ24155EVM](#) [BQ24157EVM-697](#) [BQ24160EVM-742](#) [BQ24296MEVM-655](#) [BQ25010EVM](#) [BQ3055EVM](#) [NCV891330PD50GEVB](#) [ISLUSBI2CKIT1Z](#) [LM2744EVAL](#) [LM2854EVAL](#) [LM3658SD-AEV/NOPB](#) [LM3658SDEV/NOPB](#) [LM3691TL-1.8EV/NOPB](#) [LM4510SDEV/NOPB](#) [LM5033SD-EVAL](#) [LP38512TS-1.8EV](#) [EVAL-ADM1186-1MBZ](#) [EVAL-ADM1186-2MBZ](#)