

QUICK START GUIDE FOR DEMONSTRATION CIRCUIT 1129A SYNCHRONOUS STEP-DOWN DC/DC CONVERTER

LTC3610EWP

DESCRIPTION

Demonstration circuit DC1129A is a synchronous step down converter featuring the LTC[®]3610, the high efficiency, high density DC/DC regulator. The input voltage range is from 4.5V to 24V. The output voltage is jumper selectable from 1.2V to 2.5V. The rated load current is 12A. The regulator includes the controller and power MOSFETs in the 9mm by 9 mm QFN package.

The constant on time valley mode current control structure delivers very low duty cycle with excellent load transient response. The MSFET RDS(on) sensing

eliminates external sensing resistor and improves supply efficiency.

Discontinuous mode operation and continuous mode at light load is also jumper selectable. A forced continuous control reduces noise and RF interference while discontinuous control provides high efficiency at light loads.

Design files for this circuit board are available. Call the LTC Factory.

 , LTC and LT are registered trademarks of Linear Technology Corporation.

Table 1. Performance Summary (T_A = 25°C)

PARAMETER	CONDITION	VALUE
Minimum Input Voltage		4.5V
Maximum Input Voltage		24V
Output Voltage V _{OUT}	Jumper selectable (open for 0.6V)	1.2V, 1.5V, 1.8V, 2.5V ± 2%
Maximum Continuous Output Current	De-rating is necessary for certain V _{IN} , V _{OUT} , and thermal conditions, see datasheet	12A _{DC}
Operating Frequency	Programmable	750kHz
Efficiency	V _{IN} =12V, V _{OUT} =1.5V, I _{OUT} =12A	83%, See Figure 3
Load Transient	V _{IN} =12V, V _{OUT} =1.5V	See Figure 5

QUICK START PROCEDURE

Demonstration circuit DC1129A is easy to set up to evaluate the performance of the LTC3610. Please refer to Figure 1 for proper measurement equipment setup and follow the procedure below:

1. Place jumpers in the following positions for a typical 1.5V_{OUT} application:

Vout Select	RUN	FCB
1.5V	ON	CCM

2. With power off, connect the input power supply, load and meters as shown in Figure 1. Preset the load to 0A and Vin supply to be less than 24V.
3. Turn on the power at the input. The output voltage should be 1.5V ± 2%.
4. Once the proper output voltage is established, adjust the load within the operating range and observe the output voltage regulation, ripple voltage, efficiency and other parameters. Output ripple should be measured across the output bulk capacitor as shown in Figure 2.
5. For optional load transient test, apply adjustable pulse signal between IOSTEP CLK and GND pins. Pulse amplitude sets the current

QUICK START GUIDE FOR DEMONSTRATION CIRCUIT 1129A SYNCHRONOUS STEP-DOWN DC/DC CONVERTER

step. The pulse signal should have very small duty cycle (<5%) to limit the thermal stress on the transient load circuit. The output transient current can be monitored at BNC connector J6 (5mV/A). Output voltage transient response should be measured at J5 with a BNC cable.

Output voltage transient response should be measured at J5 with a BNC cable.

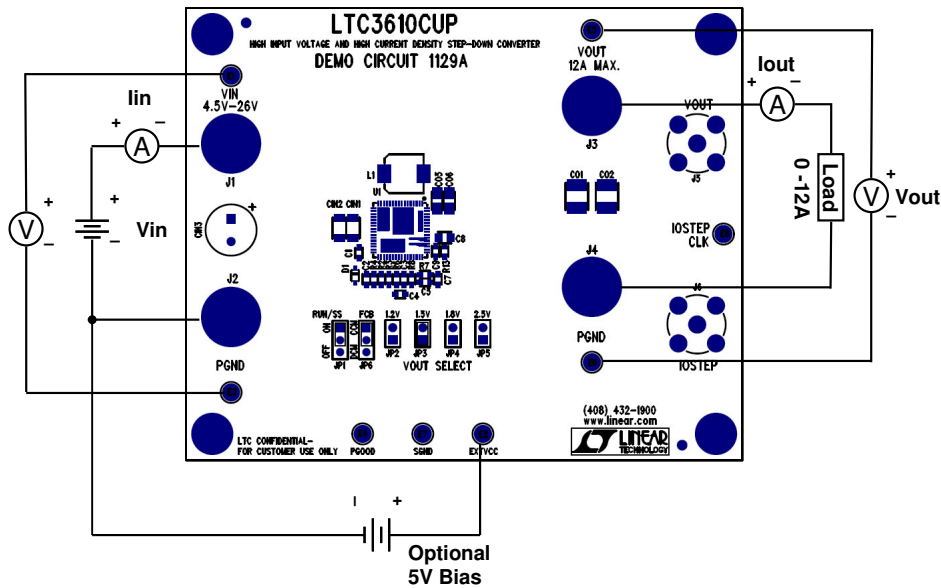

Figure 1. Test Setup of DC1129A (EXTVCC Bias Supply is Optional)

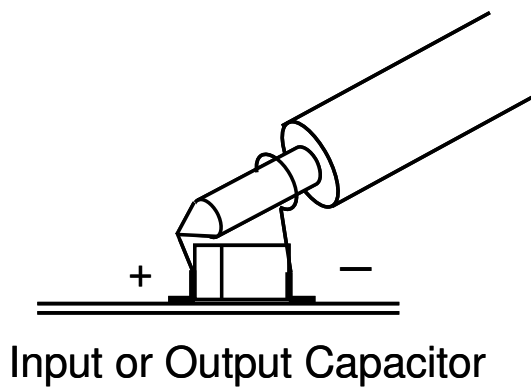

Figure 2. Scope Probe Placements for Measuring Input or Output Ripple.

QUICK START GUIDE FOR DEMONSTRATION CIRCUIT 1129A SYNCHRONOUS STEP-DOWN DC/DC CONVERTER

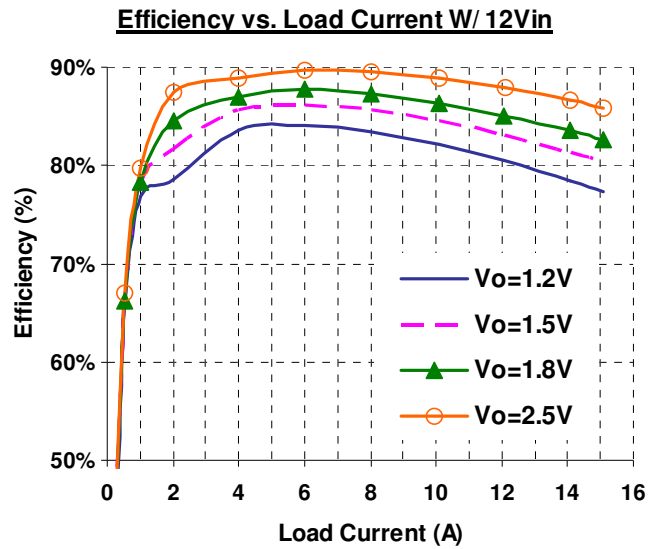

Figure 3. Measured Supply Efficiency with Different V_{IN} and V_{OUT}

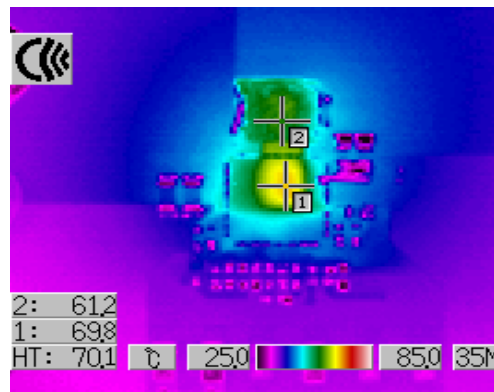

Figure 4. Thermal image of DC1129

$V_{in} = 12V$

$V_{out} = 1.5V$

$I_{out} = 12A$

$T_{ambient} = 25^{\circ}C$, No airflow

Cross 1: MOSFETs

Cross 2: Inductor

QUICK START GUIDE FOR DEMONSTRATION CIRCUIT 1129A SYNCHRONOUS STEP-DOWN DC/DC CONVERTER

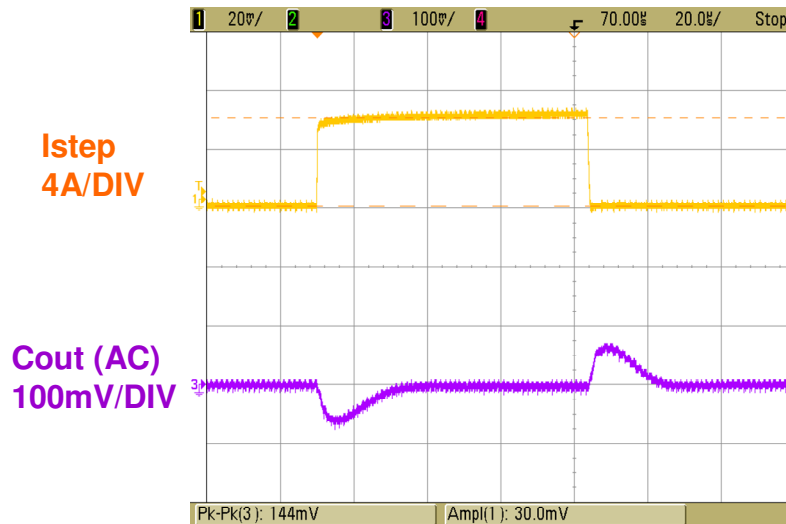

$V_{in} = 12V$

$V_{out} = 1.5V$

3A to 9A LOAD STEP

$C_{out} = 2 \times 22\mu F$ ceramic, X5R, 0805, $2 \times 100\mu F$ ceramic, X5R, 1812

Figure 5. Measured Load Transient Response (3-9A Step, 25% to 75%)

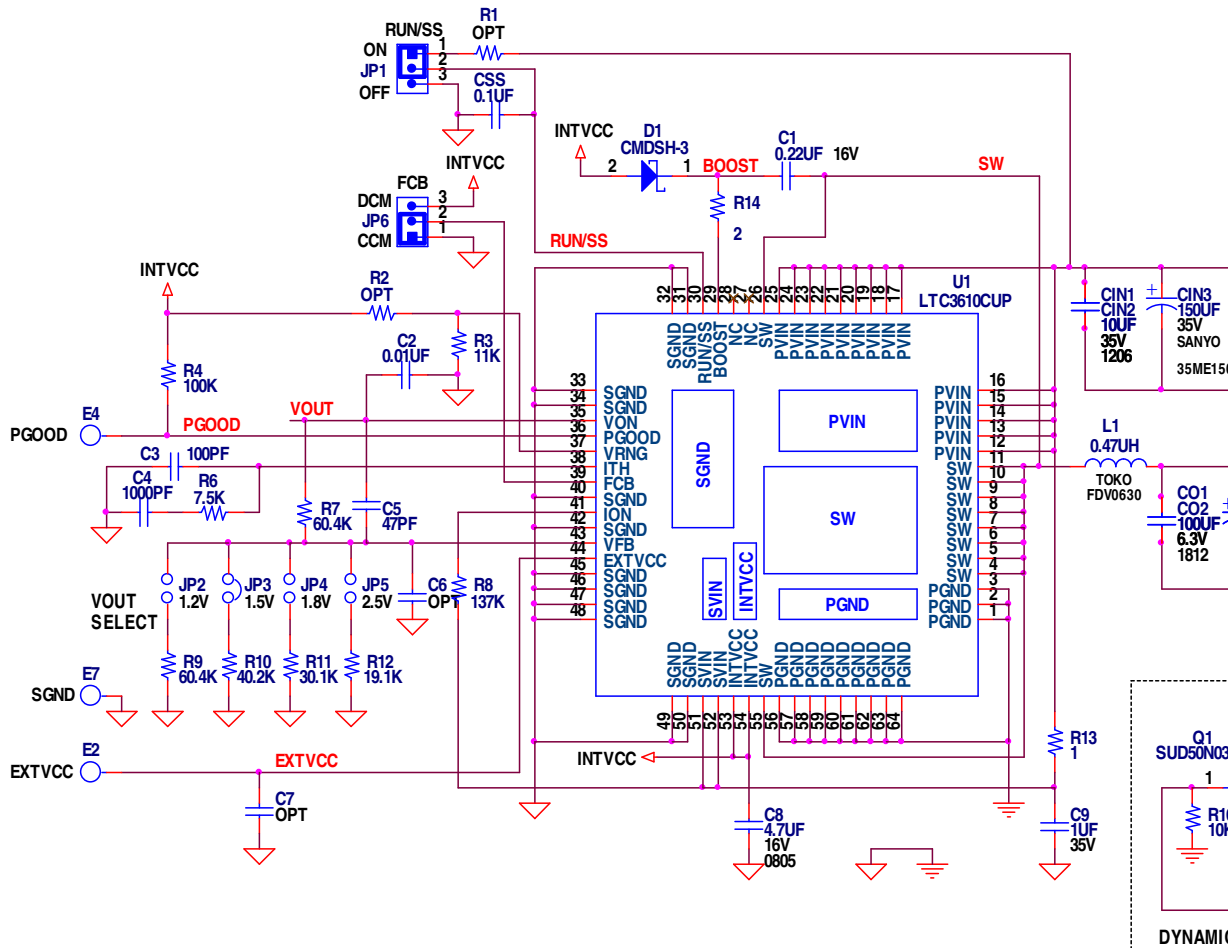

NOTES: UNLESS OTHERWISE SPECIFIED

1. ALL RESISTORS ARE IN OHMS, 0603.
ALL CAPACITORS ARE 0603.
2. INSTALL SHUNT ON JP1 PINS 1 AND 2, JP3.

CUSTOMER NOTICE

LINEAR TECHNOLOGY HAS MADE A BEST EFFORT TO DESIGN A CIRCUIT THAT MEETS CUSTOMER-SUPPLIED SPECIFICATIONS; HOWEVER, IT REMAINS THE CUSTOMER'S RESPONSIBILITY TO VERIFY PROPER AND RELIABLE OPERATION IN THE ACTUAL APPLICATION. COMPONENT SUBSTITUTION AND PRINTED CIRCUIT BOARD LAYOUT MAY SIGNIFICANTLY AFFECT CIRCUIT PERFORMANCE OR RELIABILITY. CONTACT LINEAR TECHNOLOGY APPLICATIONS ENGINEERING FOR ASSISTANCE.

THIS CIRCUIT IS PROPRIETARY TO LINEAR TECHNOLOGY AND SUPPLIED FOR USE WITH LINEAR TECHNOLOGY PARTS.

CONTRACT NO.

APPROVALS

DRAWN: KIM T.

CHECKED:

APPROVED:

ENGINEER: MANJING X.

DESIGNER:



TITLE: SCHEMATIC

HIGH INPUT VOLTAGE AND HIGH

SIZE
A

DWG NO.

DC112

DATE:

Tuesday, March 27

QUICK START GUIDE FOR DEMONSTRATION CIRCUIT 1129A SYNCHRONOUS STEP-DOWN DC/DC CONVERTER

DC1129A BOM

Item	Qty	Reference	Part Description	Manufacturer / Part #
REQUIRED CIRCUIT COMPONENTS				
1	2	CIN1,CIN2	CAP., X5R, 10UF 35V, 1206	TAIYO YUDEN, GDK316BJ106ML
2	1	CIN3	CAP., ELECTROLYTIC, 150UF 35V	SANYO, 35ME150WXV+TS
3	2	CO1,CO2	CAP., X5R, 100UF 6.3V 20%, 1812	TDK, C4532X5R0J107MT
4	2	CO5,CO6	CAP., X5R, 22UF 6.3V 20%, 0805	TDK, C2012X5R0J226M
5	1	CSS	CAP., X7R, 0.1UF 25V 20%, 0603	TDK, C1608X7R1E104M
6	1	C1	CAP., X7R, 0.22UF 16V 20%, 0603	TDK, C1608X7R1C224M
7	1	C2	CAP., X7R, 0.01UF 25V 20%, 0603	TDK, C1608X7R1E103M
8	1	C3	CAP., NPO, 100PF 50V, 0603	AVX, 06035A101KAT2A
9	1	C4	CAP., NPO, 1000PF 50V, 0603	AVX, 06035A102KAT2A
10	1	C5	CAP., NPO, 47PF 50V 10%, 0603	AVX, 06035A470KAT2A
11	1	C8	CAP., X5R, 4.7UF 16V, 0805	TDK, C2012X5R1C475M
12	1	C9	CAP., X5R, 1UF 35V 20%, 0603	TAIYO YUDEN, GMK107BJ105MA-T
13	1	D1	DIODE,SCHOTTKY, SOD323	CENTRAL SEMI., CMDSH-3
14	1	L1	IND, 0.47UH, L-TOKO-FDV0630	TOKO, FDV0630-R47M=P3
15	0	L1	IND, 0.36UH, L-TOKO-FDH1040 OPT	TOKO, FDH1040B-R36M=P3
16	1	R3	RES., Chip 11K 1/16W 5%,0603	AAC, CR16-113JM
17	1	R6	RES., Chip 7.5K 1/16W 1%,0603	AAC, CR16-7501FM
18	1	R7	RES., Chip 60.4K 1/16W 1%,0603	AAC, CR16-6042FM
19	1	R8	RES., Chip 137K 1/16W 1%,0603	AAC, CR16-1373FM
20	1	R10	RES., Chip 40.2K 1/16W 1%,0603	AAC, CR16-4022FM
21	1	R13	RES., Chip 1 1/16W 5%,0603	AAC, CR16-1R0JM
22	1	R14	RES., Chip 2 1/16W 5%,0603	AAC, CR16-2R0JM
23	1	U1	I.C., LTC3610EWP, QFN64UP	LINEAR TECH., LTC3610EWP
ADDITIONAL DEMO BOARD CIRCUIT COMPONENTS				
1	0	CIN4,CIN5	CAP., 1210	OPT
2	0	CIN6,CIN7	CAP., 1206	OPT
3	0	CO3,CO4	CAP., 7343	OPT
4	0	C6,C7	CAP., 0603	OPT
5	1	C10	CAP., X5R, 4.7UF 6.3V 10%, 0603	AVX, 06036D475KAT
6	1	Q1	XTER, N-CH, 30V, DPAK-TO252AA	VISHAY, SUD50N03-10CP
7	0	R1	RES., 0603	OPT
8	0	R2	RES., Chip 39.2K 1/16W 1%,0603	AAC, CR16-3922FM
9	1	R4	RES., Chip 100K 1/16W 5%,0603	AAC, CR16-104JM
10	1	R5	RES., Chip 0.005 1W 1%,2512	PANASONIC, ERJM1WSF5M0U
11	1	R9	RES., Chip 60.4K 1/16W 1%,0603	AAC, CR16-6042FM
12	1	R11	RES., Chip 30.1K 1/16W 1%,0603	AAC, CR16-3012FM
13	1	R12	RES., Chip 19.1K 1/16W 1%,0603	AAC, CR16-1912FM
14	1	R16	RES., Chip 10K 1/16W 5%,0603	AAC, CR16-103JM
HARDWARE FOR DEMO BOARD ONLY				
1	8	E1,E2,E3,E4,E5,E6,E7,E8	TESTPOINT, TURRET, 0.064"	MILL-MAX, 2308-2
2	2	JP1,JP6	JMP, 3PIN 1 ROW .079CC	SAMTEC, TMM-103-02-L-S
3	4	JP2,JP3,JP4,JP5	JMP, 2PIN 1 ROW .079CC	SAMTEC, TMM-102-02-L-S
4	3	SHUNTS ON JP1&JP6 PINS 1&2, AND JP3	SHUNT, .079" CENTER	SAMTEC, 2SN-BK-G
5	4	J1,J2,J3,J4	JACK, BANANA,KEY-575	KEYSTONE, 575-4
6	2	J5,J6	CONN, BNC, 50 OHMS	CONNEX, 112404
7	4	MTG 4 CORNERS	STAND-OFF, NYLON (SNAP ON), 0.50" TALL	KEYSTONE, 8833

X-ON Electronics

Largest Supplier of Electrical and Electronic Components

Click to view similar products for [Power Management IC Development Tools](#) category:

Click to view products by [Analog Devices](#) manufacturer:

Other Similar products are found below :

[EVAL-ADM1168LQEBZ](#) [EVB-EP5348UI](#) [MIC23451-AAAYFL EV](#) [MIC5281YMME EV](#) [DA9063-EVAL](#) [ADP122-3.3-EVALZ](#) [ADP130-0.8-EVALZ](#) [ADP130-1.2-EVALZ](#) [ADP130-1.5-EVALZ](#) [ADP130-1.8-EVALZ](#) [ADP1714-3.3-EVALZ](#) [ADP1716-2.5-EVALZ](#) [ADP1740-1.5-EVALZ](#) [ADP1752-1.5-EVALZ](#) [ADP1828LC-EVALZ](#) [ADP1870-0.3-EVALZ](#) [ADP1871-0.6-EVALZ](#) [ADP1873-0.6-EVALZ](#) [ADP1874-0.3-EVALZ](#) [ADP1882-1.0-EVALZ](#) [ADP199CB-EVALZ](#) [ADP2102-1.25-EVALZ](#) [ADP2102-1.875EVALZ](#) [ADP2102-1.8-EVALZ](#) [ADP2102-2-EVALZ](#) [ADP2102-3-EVALZ](#) [ADP2102-4-EVALZ](#) [ADP2106-1.8-EVALZ](#) [ADP2147CB-110EVALZ](#) [AS3606-DB](#) [BQ24010EVM](#) [BQ24075TEVM](#) [BQ24155EVM](#) [BQ24157EVM-697](#) [BQ24160EVM-742](#) [BQ24296MEVM-655](#) [BQ25010EVM](#) [BQ3055EVM](#) [NCV891330PD50GEVB](#) [ISLUSBI2CKIT1Z](#) [LM2744EVAL](#) [LM2854EVAL](#) [LM3658SD-AEV/NOPB](#) [LM3658SDEV/NOPB](#) [LM3691TL-1.8EV/NOPB](#) [LM4510SDEV/NOPB](#) [LM5033SD-EVAL](#) [LP38512TS-1.8EV](#) [EVAL-ADM1186-1MBZ](#) [EVAL-ADM1186-2MBZ](#)