

## LTC3557/LTC3557-1 + LT3505

### DESCRIPTION

The DC1138A-A/B contains the LTC3557/LTC3557-1 Power Management Integrated Circuit (PMIC) plus the LT3505EDD high voltage buck controller. The LTC3557/LTC3557-1 is a highly integrated power management IC that includes a PowerPath controller, battery charger, an ideal diode, an always-on LDO, three synchronous step-down switching regulators as well as a buck regulator VC controller. Designed specifically for USB applications, the PowerPath controller incorporates a precision input current limit which communicates with the battery charger to ensure that the input current does not violate the USB specification. The ideal diode from BAT to VOUT guarantees that ample power is always available to VOUT even if there is insufficient or absent power at VBUS.

The LTC3557/LTC3557-1 also has the ability to receive power from a wall adapter or other non-current-limited power source. Such a power supply can be connected to the VOUT pin of the LTC3557/LTC3557-1 through an external device such as a power Schottky diode or MOSFET, Q1, as shown in the demo board circuit schematic, Figure 4. The LTC3557/LTC3557-1 has the unique ability to use the output, which is powered by an external supply, to charge the battery while providing power to the load. A comparator on the WALL pin is configured to detect the presence of the wall adapter and shut off the power connection between VOUT and the USB input. This prevents reverse conduction from VOUT to VBUS when a wall adapter is present.

The LTC3557/LTC3557-1 provides a VC output pin which can be used to drive the VC pin of an external high voltage buck switching regulator such as the LT3480, LT3481, or LT3505 to provide power to the VOUT pin. The VC control circuitry adjusts the regulation point of the switching regulator such that VOUT equals the greater of BAT plus 300mV or 3.6 Volts. This control method pro-

vides a high input voltage, high efficiency battery charger and PowerPath function. An always-on LDO provides a regulated 3.3V from VOUT. This LDO will be on at all times and can be used to supply up to 25mA.

The LTC3557/LTC3557-1 includes three 2.25MHz constant frequency current mode step-down switching regulators providing 400mA, 400mA and 600mA. All step-down switching regulators can be programmed for a minimum output voltage of 0.8V and can be used to power a microcontroller core, I/O, memory or other logic circuitry. All step-down switching regulators support 100% duty cycle operation and are capable of operating in Burst Mode operation for highest efficiencies at light loads (Burst Mode operation is pin selectable). No external compensation components are required for the switching regulators.

The LTC3557/LTC3557-1 is available in a 28-pin low profile (4mm x 4mm x 0.75mm) QFN package.

**Design files for this circuit board are available by calling the LTC factory.**

LT, LTC, LT and Burst Mode are registered trademarks of Linear Technology Corporation. PowerPath is a trademark of LinearTechnology Corporation. Other product names may be trademarks of the companies that manufacture the products.

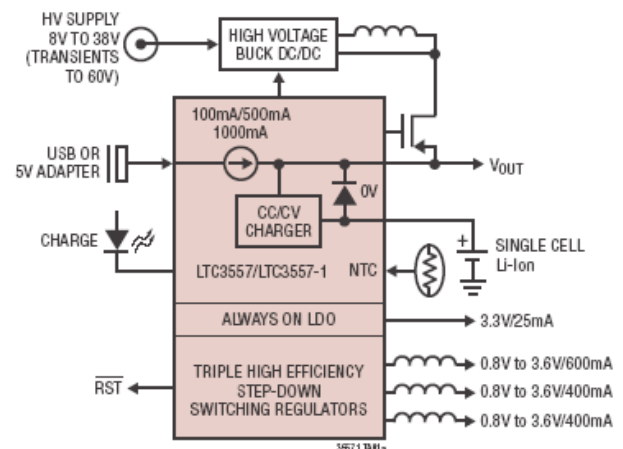

Figure 1. LTC3557/LTC3557-1 Simplified Typical Application

**Table 1. Typical Specifications (25°C)**

| PARAMETER                                       | RANGE   |
|---|---|
| VBUS  | 4.35V to 5.5V   |
| 5V ADAPTER                                      | 4.5V to 5.5V  |
| HVIN  | 8V to 36V   |
| VOUT  | 2.9V – 5.5V, 1.2A   |
| VOUT1   | 3.3V, 600mA   |
| VOUT2   | 1.2V, 400mA   |
| VOUT3   | 1.8V, 400mA   |
| LDO3V3  | 3.3V, 25mA  |
| Battery Float Voltage in Constant Voltage Mode  | LTC3557EUF = 4.2V (DC1138A-A),<br>LTC3557EUF-1 = 4.1V (DC1138A-B) |
| Battery Charge Current in Constant Current Mode | 500mA (R <sub>PROG</sub> = 2K Ohms)                               |

## QUICK START PROCEDURE

Demo Circuit 1138 is best evaluated using a lithium ion battery. The test set-up in Figure 2 shows a battery simulator, consisting of PS4 and a 3.6 Ohm power resistor. Since the demo circuit is designed to possibly be used with a battery simulator, it includes a capacitor between the BAT and GND terminals with some series resistance. Please see the Applications Section below for a detailed discussion of selecting the proper bypass capacitor and series resistance for the BAT terminal.

Refer to Figure 2 for the proper measurement and equipment setup and follow the procedure below.

1. Set all Power Supplies to zero volts and all loads to zero amps and then connect the test equipment as shown in Figure 2. If using the USB input option, have cable ready to plug in for when all loads and jumpers are set. **Do not use the USB input and an external supply at the same time.**

2. Set the NTC jumper to INT to use the demo board resistors. To use an external NTC resistor, connect an NTC resistor between J2-3 (ENTC) and GND. Then set the NTC jumper to EXT.
3. Use Table 2 to set ILIM1 and ILIM0 to select the desired input current limit.

**Table 2. Maximum Current Limit Settings**

| ILIM1 | ILIM0 | MAXIMUM INPUT CURRENT LIMIT |
|-------|-------|-----------------------------|
| 0     | 0     | 100mA                       |
| 0     | 1     | 1A                          |
| 1     | 0     | SUSPEND                     |
| 1     | 1     | 500mA                       |

4. Set EN1, EN2 and EN3 to ON.
5. Set PS4 to 3.6 Volts. Alternatively, PS4 and the Power resistor could be replaced with a lithium ion battery conditioned to 3.6 Volts. Observe VOUT, VOUT1, VOUT2, VOUT3 and LDO3V3 outputs.

## LTC3557/LTC3557-1 + LT3505

6. If using the USB input, plug in the USB cable and observe the charge current and VOUT. If using an external VBUS power supply slowly increase PS3, and observe that the LTC3557/LTC3557-1 starts to use the VBUS input power as the device reaches 3.9 Volts. Increase the VBUS supply until it reaches 5.0 Volts.
7. Discharge the battery voltage to 2.6 Volts and then reconnect the battery or reduce PS4 to 2.6 Volts to observe that the LTC3557/LTC3557-1 is now charging in trickle charge mode and the charge current is 1/10th of the maximum programmed charge current. As the battery voltage increases above 2.85 Volts observe that the charge current increases to the maximum programmed value.
8. Remove the NTC jumper on JP9. Observe the CHRG LED slow blinking rate. Also observe the 35KHz pulse-width varying duty cycle between 4.7% and 95.3% on the  $\overline{\text{CHRG}}$  terminal with an oscilloscope. Reinstall the NTC jumper to INT and observe the solid CHRG LED.
9. Increase the VOUT load and observe when the input current starts to limit. When the VOUT load exceeds the input current limit, additional load smoothly transitions to the battery through the ideal diode and VOUT drops to the battery voltage minus the voltage drop across the ideal diode (~15mV).
10. Repeat step 9 with different ILIM1 and ILIM0 settings.
11. With the VBUS input supply, PS3, equal to 5 Volts. Observe the battery current as the battery voltage increases above 4.05 Volts. The charge current starts to decrease as the battery voltage approaches 50mV less than the float voltage.
12. Vary PS3 and observe the reduction of charge current as VBUS is decreased below 5.0 Volts.
13. Set PS3 to 5.0 Volts. Set LOAD1, LOAD2 and LOAD3 for the intended application to test various operating conditions of the intended application. Observe  $\overline{\text{RST2}}$  going high as VOUT2 comes into regulation.
14. Verify that jumper JP10 is set to HV BUCK. Slowly increase PS1 to 8 Volts and observe that the current through PS3 is reduced to zero amps as the HV BUCK voltage reaches 4.5 Volts. Continue to increase PS1 to 12 Volts.
15. Observe VOUT as the BAT voltage varies. VOUT will now track the battery voltage with a constant 300mV offset, which reduces power dissipation in the battery charger.
16. Disconnect the positive lead of the battery from the BAT terminal and observe the float voltage of the battery charger.  
**VFLOAT = 4.2V for LTC3557EUF (DC1138A-A)**  
**VFLOAT = 4.1V for LTC3557EUF-1 (DC1138A-B)**

See the LTC3557 data sheet for additional information about how this part performs.

## APPLICATION INFORMATION

This demonstration circuit is designed to demonstrate the full capability of the device. Not all components are required in all applications. The critical circuit components are on the top of the board near the IC.

The input capacitor network of C6 and R25 is used to dampen input source inductances that commonly occur in laboratory setups with twisted leads and a bench power supply. When using a USB cable or adaptor cable this input damping network will likely not be required. Please note that the in-circuit capacitance of the specified 10uF, 0805 ceramic capacitor for C6 and C7 is approximately 5uF each at applied voltage.

Capacitor C18 in series with R24 are included to simulate a low impedance battery. They are especially helpful when testing the demo circuit with a battery simulator comprised of a power supply with a 3.6 Ohm power resistor across it. The leads connecting the power supply to the demo circuit should be a short twisted pair to minimize lead inductance. Capacitor C18 and

R24 will also provide proper operation of the circuit without a battery present. Capacitor C18 and R24 are a 100uF OSCON capacitor in series with a zero Ohm jumper from the BAT terminal to GND. When measuring the BAT discharge current or for an application circuit, it is recommended that this OSCON capacitor be replaced with a 100uF, ceramic capacitor and R24 be changed to between 250 and 350 mOhms. The ceramic capacitor used must maintain at least 47uF of real capacitance with 4.5 Volts DC applied.

Please contact the factory if you would like to use the SHDN function of the LT3505EDD high voltage buck. The circuit as configured will operate properly with HVIN either present or not present, but the SHDN pin on the LT3505 does not shut down the part when the VC pin of the LT3505 is connected directly to the VC pin of the LTC3557/LTC3557-1.

# QUICK START GUIDE FOR DEMONSTRATION CIRCUIT 1138A-A/B USB POWER MANAGER WITH LI-ION CHARGER AND TRIPLE BUCK REGULATORS

## LTC3557/LTC3557-1 + LT3505

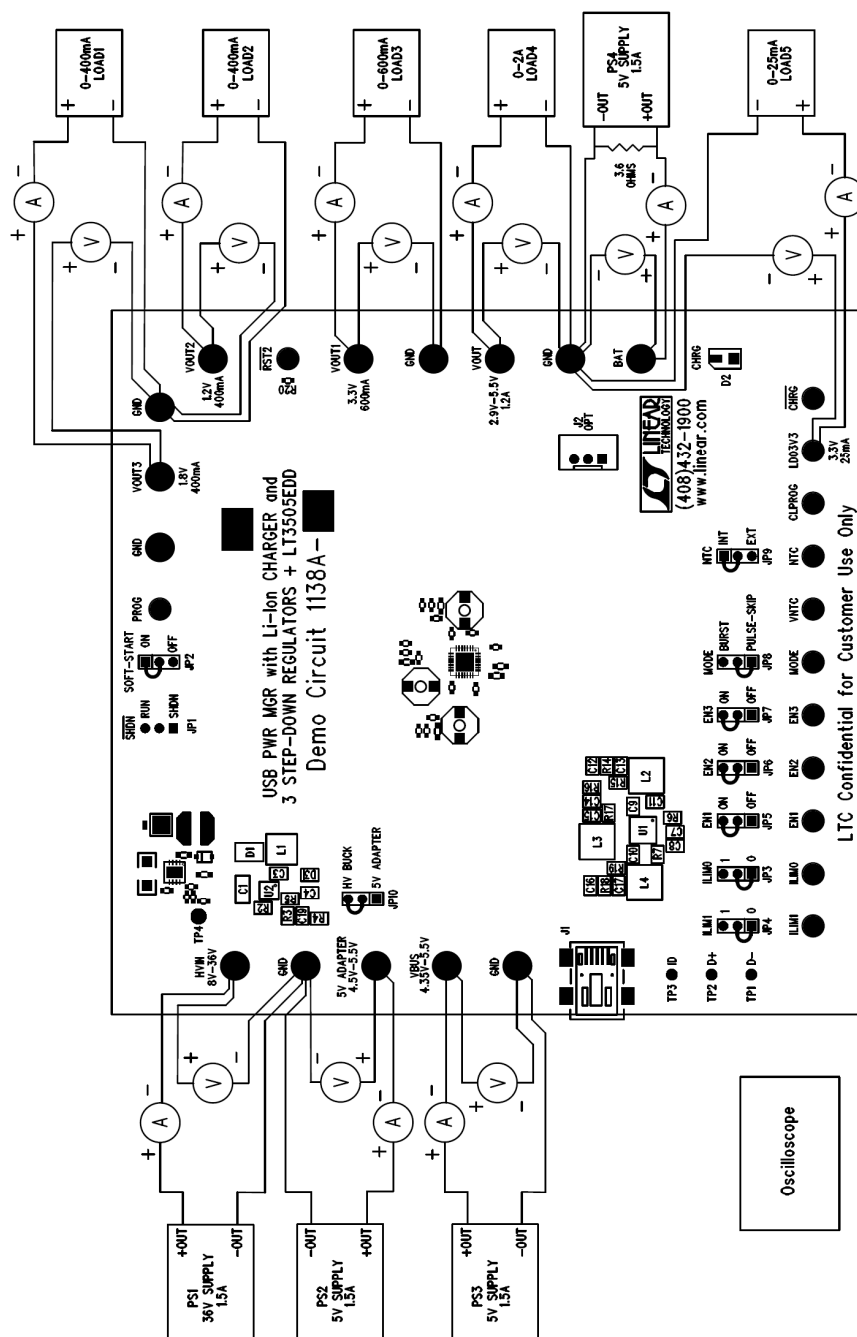

Figure 2. Proper Equipment Setup for DC1138A-A/B

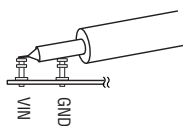

Figure 3. Measuring Input or Output Ripple



# QUICK START GUIDE FOR DEMONSTRATION CIRCUIT 1138A-A/B USB POWER MANAGER WITH Li-ION CHARGER AND TRIPLE BUCK REGULATORS

## LTC3557/LTC3557-1 + LT3505

**Linear Technology Corp.**

LTC3557EUF, LTC3557EUF-1

Parts List

**Bill Of Material**

**Demo Circuit #: 1138A-A/B,**

**Rev B**

3/12/2008

| Item   | Qty | Reference - Des                                      | Part Description   | Manufacturer, Part #  |
|--|-----|--|--|---|
| <b>REQUIRED CIRCUIT COMPONENTS:</b>              |     |  |  |   |
| 1  | 5   | C7,C8,C13,C15,C17                                    | CAP, X5R, 10uF, 6.3V, 20%, 0603                                      | TDK, C1608X5R0J106M   |
| 2  | 2   | C9,C10   | CAP, X5R, 2.2uF, 6.3V, 20%, 0402                                     | MURATA, GRM155R60J225ME15                                     |
| 3  | 1   | C11  | CAP, X5R, 1.0uF, 6.3V, 10%, 0402                                     | MURATA, GRM155R60J105KE19                                     |
| 4  | 3   | C12,C14,C16  | CAP, NPO, 10pF, 25V, 10%, 0402                                       | AVX, 04023A100KAT   |
| 5  | 1   | R6   | RES, 0402, 2.10K, OHM, 1%, 1/16W                                     | VISHAY, CRCW040222K10FKED                                     |
| 6  | 1   | R7   | RES, 0402, 2.00K, OHM, 1%, 1/16W                                     | VISHAY, CRCW04022K00FKED                                      |
| 7  | 1   | R14  | RES, 0402, 1.02M, OHMS, 1%, 1/16W                                    | VISHAY, CRCW04021M02FKED                                      |
| 8  | 1   | R15  | RES, 0402, 324K, OHM, 1%, 1/16W                                      | VISHAY, CRCW0402324KFKED                                      |
| 9  | 1   | R16  | RES, 0402, 232K, OHM, 1%, 1/16W                                      | VISHAY, CRCW0402232KFKED                                      |
| 10   | 1   | R17  | RES, 0402, 464K, OHM, 1%, 1/16W                                      | VISHAY, CRCW0402464KFKED                                      |
| 11   | 1   | R18  | RES, 0402, 806K, OHM, 1%, 1/16W                                      | VISHAY, CRCW0402806KFKED                                      |
| 12   | 1   | R19  | RES, 0402, 649K, OHM, 1%, 1/16W                                      | VISHAY, CRCW0402649KFKED                                      |
| 13   | 1   | L2   | INDUCTOR, 3.3uH, 0.100 Ohms, 1.5A                                    | TOKO, 1098AS-3R3M   |
| 14   | 2   | L3,L4  | INDUCTOR, 4.7uH, 0.130 Ohms, 1.3A                                    | TOKO, 1098AS-4R7M   |
| 15   | 1   | U1   | USB POWER MANAGER WITH Li-Ion CHARGER AND THREE STEP-DOWN REGULATORS | LINEAR TECH, DC1138A-A = LTC3557EUF, DC1138A-B = LTC3557EUF-1 |
| <b>ADDITIONAL DEMO BOARD CIRCUIT COMPONENTS:</b> |     |  |  |   |
| 1  | 1   | C1   | CAP, X7R, 1.0uF, 50V, 10%, 1206                                      | MURATA, GRM31MR71H105KA88                                     |
| 2  | 1   | C2   | CAP, X7R, 0.068uF, 50V, 10%, 0805                                    | MURATA, GRM21BR71H683KA01L                                    |
| 3  | 1   | C3   | CAP, X7R, 0.1uF, 25V, 10%, 0603                                      | MURATA, GRM188R71E104KA01D                                    |
| 4  | 3   | C4,C5,C6   | CAP, X5R, 10uF, 6.3V, 20%, 0603                                      | TDK, C1608X5R0J106M   |
| 5  | 1   | C18  | CAP, CHIP, OS-CON, 100uF, 6.3V, B6                                   | SANYO, 6SVPC100MY   |
| 6  | 1   | C19  | CAP, NPO, 22pF, 25V, 10%, 0402                                       | AVX, 04023A220KAT   |
| 7  | 1   | R1   | RES, 0402, 150K OHMS, 1%, 1/16W                                      | VISHAY, CRCW0402150KFKED                                      |
| 8  | 1   | R2   | RES, 0402, 20.0K OHMS, 1%, 1/16W                                     | VISHAY, CRCW040220K0FKED                                      |
| 9  | 1   | R3   | RES, 0402, 49.9K OHMS, 1%, 1/16W                                     | VISHAY, CRCW040249K9FKED                                      |
| 10   | 4   | R4,R21,R22,R23                                       | RES, 0402 20.0 OHM 1% 1/16W  | VISHAY CRCW040220R0FNED                                       |
| 11   | 1   | R5   | RES, 0402, 10.2K OHMS, 1%, 1/16W                                     | VISHAY, CRCW040210K2FKED                                      |
| 12   | 3   | R8,R9,R20  | RES, 0402, 100K OHMS, 1%, 1/16W                                      | VISHAY, CRCW0402100KFKED                                      |
| 13   | 3   | R10, R11,R24   | RES, 0402 0 OHMS 1/16W   | VISHAY CRCW04020000Z0ED                                       |
| 14   | 1   | R12  | RES, 0402 806K OHM 1% 1/16W  | VISHAY, CRCW0402806KFKED                                      |
| 15   | 1   | R13  | RES, 0402 510 OHMS 1% 1/16W  | VISHAY CRCW0402510RFNED                                       |
| 16   | 2   | R25,R26  | RES, 0402 1 OHMS 5% 1/16W  | VISHAY, CRCW04021R00JNED                                      |
| 17   | 1   | L1   | INDUCTOR, 6.8uH, 0.165 Ohms, 1.39A                                   | TDK, VLCF5020T-6R8N1R1  |
| 18   | 1   | D1   | DIODE, SCHOTTKY, 40V, POWERMITE                                      | ON SEMI, MBRM140T3G   |
| 19   | 1   | D2   | DIODE, LED, GREEN  | PANASONIC, LN1351C-(TR)                                       |
| 20   | 1   | D3   | DIODE, SCHOTTKY, 40V, SOD-323  | CENTRAL SEMI, CMDSH-4E  |
| 21   | 1   | D4   | DIODE, ZENER, 16V, SOD-523   | DIODES INC, BZT52C-16T  |
| 22   | 2   | Q1,Q2  | XSTR, MOSFET, -12V, P- CHANNEL                                       | SILICONIX, Si2333DS   |
| 23   | 1   | U2   | 1.2A, STEP-DOWN SWITCHING REGULATOR IN 3mm x 3mm DFN                 | LINEAR TECH, LT3505EDD  |
| <b>HARDWARE FOR DEMO BOARD ONLY:</b>             |     |  |  |   |
| 1  | 1   | J1   | CONN, USB MINI-B   | TYCO, 1734035-2   |
| 2  | 0   | J2 (OPT)   | CONN, DF3-3P-2DSA  | HIROSE, DF3-3P-2DSA   |
| 3  | 14  | E1,E2,E3,E14,E15,E16,E17,E19,E21,E22,E24,E25,E26,E27 | TURRET, 0.09 DIA   | MILLMAX 2501-2  |
| 4  | 13  | E4,E5,E6,E7,E8,E9,E10,E11,E12,E13,E18,E20,E23        | TURRET, 0.061 DIA  | MILLMAX 2308-2  |
| 5  | 0   | JP1  | HEADER, 3 PINS, 2mm  | SAMTEC, TMM-103-02-L-S  |
| 6  | 0   | JP1  | SHUNT, 2mm   | SAMTEC, 2SN-BK-G  |
| 7  | 9   | JP2-JP10   | HEADER, 3 PINS, 2mm  | SAMTEC, TMM-103-02-L-S  |
| 8  | 9   | JP2-JP10   | SHUNT, 2mm   | SAMTEC, 2SN-BK-G  |
| 9  | 4   |  | STAND-OFF, NYLON, 0.25" tall (SNAP ON)                               | KEYSTONE, 8831 (SNAP ON)                                      |

## X-ON Electronics

Largest Supplier of Electrical and Electronic Components

*Click to view similar products for [Power Management IC Development Tools](#) category:*

*Click to view products by [Analog Devices](#) manufacturer:*

Other Similar products are found below :

[EVAL-ADM1168LQEBZ](#) [EVB-EP5348UI](#) [MIC23451-AAAYFL EV](#) [MIC5281YMME EV](#) [DA9063-EVAL](#) [ADP122-3.3-EVALZ](#) [ADP130-0.8-EVALZ](#) [ADP130-1.2-EVALZ](#) [ADP130-1.5-EVALZ](#) [ADP130-1.8-EVALZ](#) [ADP1714-3.3-EVALZ](#) [ADP1716-2.5-EVALZ](#) [ADP1740-1.5-EVALZ](#) [ADP1752-1.5-EVALZ](#) [ADP1828LC-EVALZ](#) [ADP1870-0.3-EVALZ](#) [ADP1871-0.6-EVALZ](#) [ADP1873-0.6-EVALZ](#) [ADP1874-0.3-EVALZ](#) [ADP1882-1.0-EVALZ](#) [ADP199CB-EVALZ](#) [ADP2102-1.25-EVALZ](#) [ADP2102-1.875EVALZ](#) [ADP2102-1.8-EVALZ](#) [ADP2102-2-EVALZ](#) [ADP2102-3-EVALZ](#) [ADP2102-4-EVALZ](#) [ADP2106-1.8-EVALZ](#) [ADP2147CB-110EVALZ](#) [AS3606-DB](#) [BQ24010EVM](#) [BQ24075TEVM](#) [BQ24155EVM](#) [BQ24157EVM-697](#) [BQ24160EVM-742](#) [BQ24296MEVM-655](#) [BQ25010EVM](#) [BQ3055EVM](#) [NCV891330PD50GEVB](#) [ISLUSBI2CKIT1Z](#) [LM2744EVAL](#) [LM2854EVAL](#) [LM3658SD-AEV/NOPB](#) [LM3658SDEV/NOPB](#) [LM3691TL-1.8EV/NOPB](#) [LM4510SDEV/NOPB](#) [LM5033SD-EVAL](#) [LP38512TS-1.8EV](#) [EVAL-ADM1186-1MBZ](#) [EVAL-ADM1186-2MBZ](#)