

LTC6930-X.XX, PRECISION DIGITALLY CONTROLLED OSCILLATORS

LTC6930-4.19, LTC6930-5.00, LTC6930-7.37, LTC6930-8.00, LTC6930-8.19

32.768KHZ - 8.192MHZ

DESCRIPTION

Demonstration Circuit 1141A features the LTC6930-X.XX series family of very low power precision silicon oscillators with a frequency error less than 0.09% at 25 °C. For each oscillator, the user can select one of 8 frequencies between 32.768 kHz and 8.192 MHz. Based on fixed master oscillator frequency internal frequency dividers between 1 and 128 provide the 8 different frequencies.

The LTC6930 requires no external components other than power supply bypass capacitors and operates with a single 1.7V to 5.5V supply.

A DC1141A PCB assembly consists of a 2 inch X 2 inch buffer board with a BNC output and a DIP-8 oscillator board mounted on an 8-pin socket. The DIP-8 oscillator board can be removed from the buffer board and used for prototyping.

The three digitally controlled inputs of an LTC6930-X.XX (DIVA, DIVB and DIVC) can be set on a DC1141A-X with three jumpers or set externally by connecting wires to the on board turrets.

The Digital Input and Divider Setting:

DIVC	DIVB	DIVA	DIVIDE BY
0	0	0	1
0	0	1	2
0	1	0	4
0	1	1	8
1	0	0	16
1	0	1	32
1	1	0	64
1	1	1	128

Note: DIVC is the MSB

There are five DC1141A boards:

1. DC1141A-A with an LTC6930-4.19
2. DC1141A-B with an LTC6930-5.00
3. DC1141A-C with an LTC6930-7.37
4. DC1141A-D with an LTC6930-8.00
5. DC1141A-E with an LTC6930-8.19

Design files for these circuit boards are available.

Call the LTC factory.

 , LTC and LT are registered trademarks of Linear Technology Corporation.

THE LTC6930-X.XX FREQUENCIES

The LTC6930-4.19 (DC1141A-A)

DIVC	DIVB	DIVA	Frequency
0	0	0	4.194304MHz
0	0	1	2.097152MHz
0	1	0	1.048576MHz
0	1	1	524.288kHz
1	0	0	262.144kHz
1	0	1	131.072kHz
1	1	0	65.536kHz
1	1	1	32.768kHz

The LTC6930-5.00 (DC1141A-B)

DIVC	DIVB	DIVA	Frequency
0	0	0	5.0000MHz
0	0	1	2.5000MHz
0	1	0	1.2500MHz
0	1	1	625.000kHz
1	0	0	312.500kHz
1	0	1	156.250kHz
1	1	0	78.1250kHz
1	1	1	39.0625kHz

The LTC6930-7.37 (DC1141A-C)

DIVC	DIVB	DIVA	Frequency
0	0	0	7.3728MHz
0	0	1	3.6864MHz
0	1	0	1.8432MHz
0	1	1	921.6kHz
1	0	0	460.8kHz
1	0	1	230.4kHz
1	1	0	115.2kHz
1	1	1	57.6kHz

DC1141A QUICK START GUIDE

The LTC6930-8.00 (DC1141A-D)

DIVC	DIVB	DIVA	Frequency
0	0	0	8.000MHz
0	0	1	4.000MHz
0	1	0	2.000MHz
0	1	1	1.000MHz
1	0	0	500.0kHz
1	0	1	250.0kHz
1	1	0	125.0kHz
1	1	1	62.5kHz

The LTC6930-8.19 (DC1141A-E)

DIVC	DIVB	DIVA	Frequency
0	0	0	8.192MHz
0	0	1	4.096MHz
0	1	0	2.048MHz
0	1	1	1.024MHz
1	0	0	512.0kHz
1	0	1	256.0kHz
1	1	0	128.0kHz
1	1	1	64.0kHz

QUICK START PROCEDURE

Test Equipment:

1. A single power supply, 3V – 5V.
2. An oscilloscope with at least 100MHz bandwidth.
3. A frequency counter

Test Procedure:

1. On the DC1141A-X.XX board set the DIVA, DIVB and DIVC jumpers to the “0” position.
2. Set power supply for 3.00V.
3. Connect power supply as shown in Figure 1.
4. Connect the VOUT BFR (J1) of the board to an oscilloscope input terminated with 50ohms.
5. Turn on the power supply.
6. The oscilloscope should show a “clean” squarewave 0V to 1.375V (the LTC6930 output is 0V to 3V and is divided by two thru the on board buffer with a typical 2.75V logic high).
7. Remove the board connection to the oscilloscope and connect to a frequency counter.
8. The counter’s frequency should be equal to the highest LTC6930-X.XX frequency $\pm 0.9\%$.

Highest Frequency (DIVC, DIVB, DIVA is 000)

DC1141A-A	4.194304MHz
DC1141A-B	5.000MHz
DC1141A-C	7.3728MHz
DC1141A-D	8.000MHz
DC1141A-E	8.192MHz

End of test.

Figure 1. Quick Test Set-Up

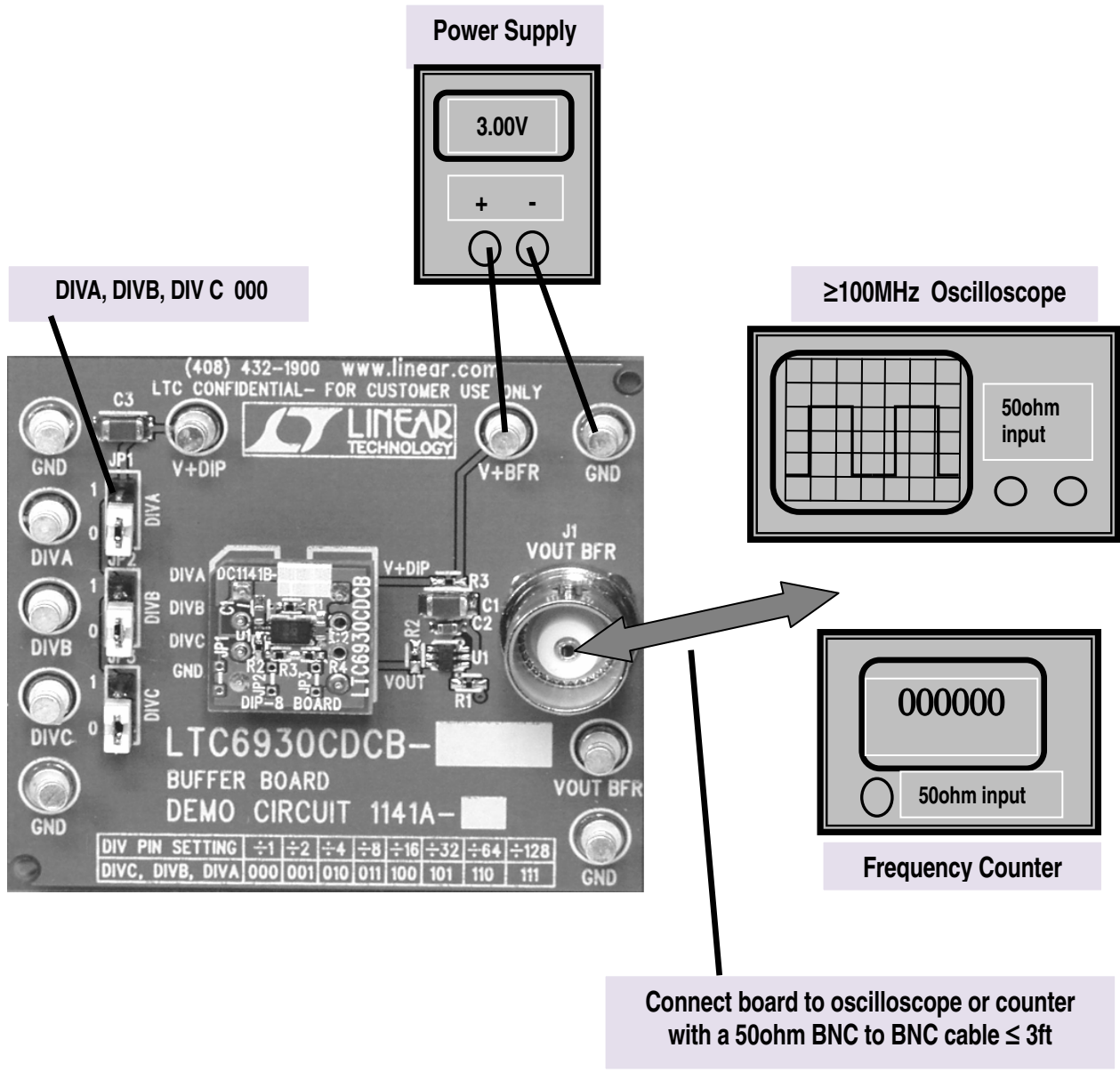

DC1141A QUICK START GUIDE

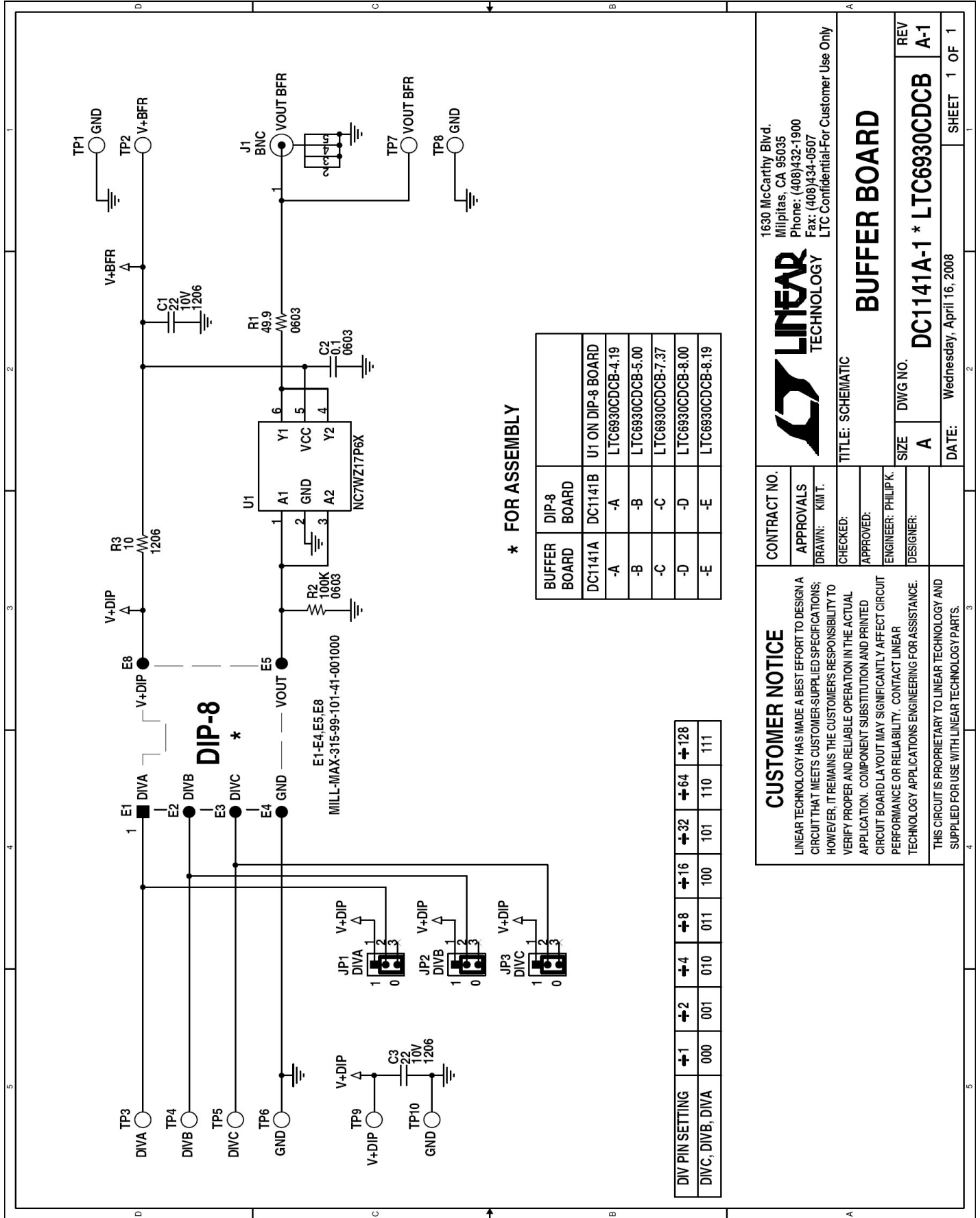

1630 McCarthy Blvd.
Milpitas, CA 95035
Phone: (408)432-1900
Fax: (408)434-0507
LTC Confidential-For Customer Use Only

LINEAR TECHNOLOGY

DC1141A-1 * LTC6930DCB A-1

DATE: Wednesday, April 16, 2008

SHEET 1 OF 1

CUSTOMER NOTICE

LINEAR TECHNOLOGY HAS MADE A BEST EFFORT TO DESIGN A CIRCUIT THAT MEETS CUSTOMER-SUPPLIED SPECIFICATIONS; HOWEVER, IT REMAINS THE CUSTOMER'S RESPONSIBILITY TO VERIFY PROPER AND RELIABLE OPERATION IN THE ACTUAL APPLICATION. COMPONENT SUBSTITUTION AND PRINTED CIRCUIT BOARD LAYOUT MAY SIGNIFICANTLY AFFECT CIRCUIT PERFORMANCE OR RELIABILITY. CONTACT LINEAR TECHNOLOGY APPLICATIONS ENGINEERING FOR ASSISTANCE.

THIS CIRCUIT IS PROPRIETARY TO LINEAR TECHNOLOGY AND SUPPLIED FOR USE WITH LINEAR TECHNOLOGY PARTS.

CONTRACT NO.

APPROVALS

DRAWN: KIM T.

CHECKED:

APPROVED:

ENGINEER: PHILIP K.

DESIGNER:

TITLE: SCHEMATIC

SIZE A

DWG NO. DC1141A-1 * LTC6930DCB

REV A-1

BUFFER BOARD

DC1141A QUICK START GUIDE

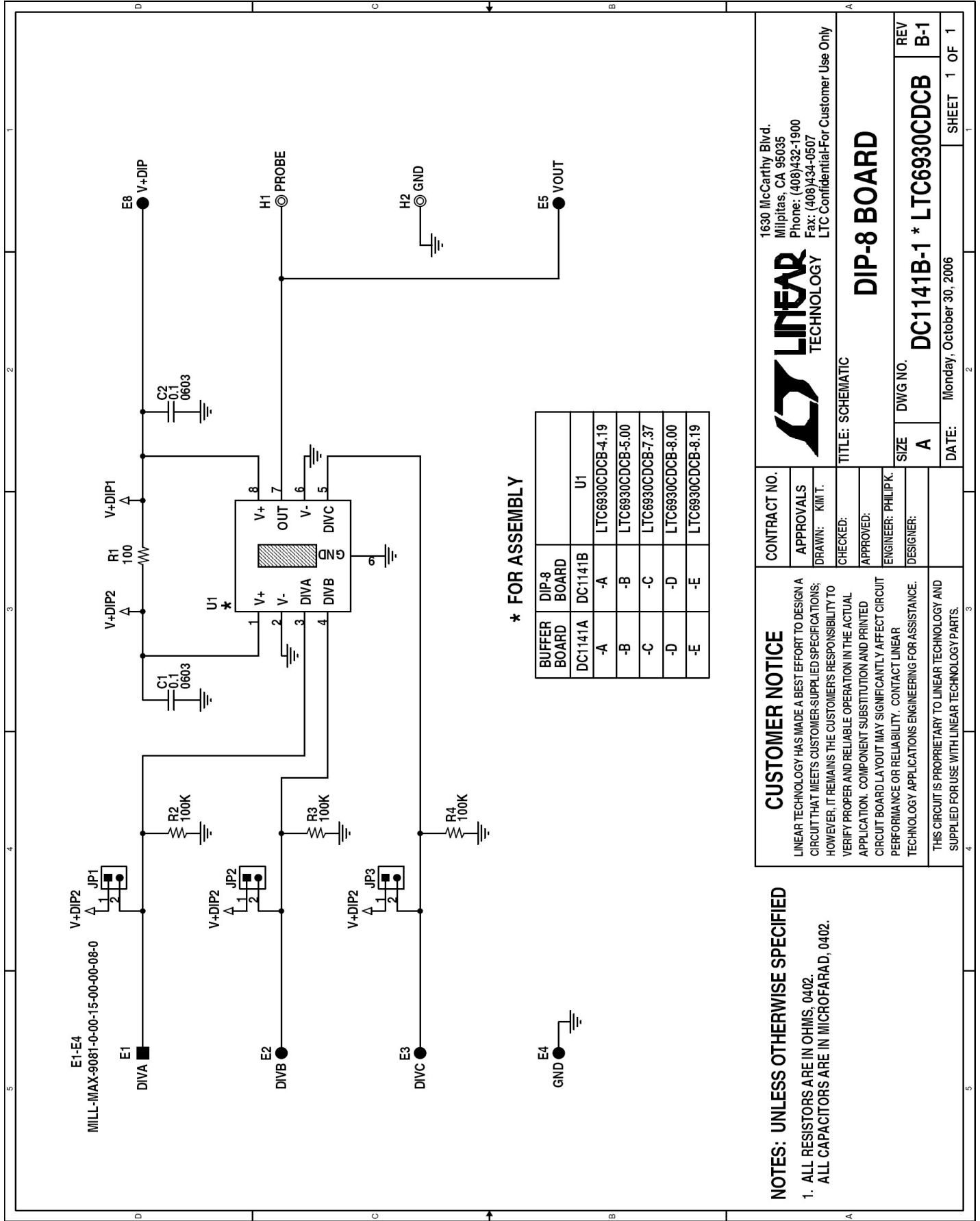

NOTES: UNLESS OTHERWISE SPECIFIED

- ALL RESISTORS ARE IN OHMS, 0402.
ALL CAPACITORS ARE IN MICROFARAD, 0402.

LINEAR TECHNOLOGY

1630 McCarthy Blvd.
Milpitas, CA 95035
Phone: (408)432-1900
Fax: (408)434-0507
LTC Confidential-For Customer Use Only

CUSTOMER NOTICE

LINEAR TECHNOLOGY HAS MADE A BEST EFFORT TO DESIGN A CIRCUIT THAT MEETS CUSTOMER-SUPPLIED SPECIFICATIONS; HOWEVER, IT REMAINS THE CUSTOMER'S RESPONSIBILITY TO VERIFY PROPER AND RELIABLE OPERATION IN THE ACTUAL APPLICATION. COMPONENT SUBSTITUTION AND PRINTED CIRCUIT BOARD LAYOUT MAY SIGNIFICANTLY AFFECT CIRCUIT PERFORMANCE OR RELIABILITY. CONTACT LINEAR TECHNOLOGY APPLICATIONS ENGINEERING FOR ASSISTANCE.

THIS CIRCUIT IS PROPRIETARY TO LINEAR TECHNOLOGY AND SUPPLIED FOR USE WITH LINEAR TECHNOLOGY PARTS.

CONTRACT NO.

APPROVALS

DRAWN: KIM T.

CHECKED:

APPROVED:

ENGINEER: PHILIPK.

DESIGNER:

LINEAR TECHNOLOGY

DIP-8 BOARD

DC1141B-1 * LTC6930DCB

REV B-1

DATE: Monday, October 30, 2006

SHEET 1 OF 1

X-ON Electronics

Largest Supplier of Electrical and Electronic Components

Click to view similar products for [Power Management IC Development Tools](#) *category:*

Click to view products by [Analog Devices](#) *manufacturer:*

Other Similar products are found below :

[EVAL-ADM1168LQEBZ](#) [EVB-EP5348UI](#) [MIC23451-AAAYFL EV](#) [MIC5281YMME EV](#) [DA9063-EVAL](#) [ADP122-3.3-EVALZ](#) [ADP130-0.8-EVALZ](#) [ADP130-1.2-EVALZ](#) [ADP130-1.5-EVALZ](#) [ADP130-1.8-EVALZ](#) [ADP1714-3.3-EVALZ](#) [ADP1716-2.5-EVALZ](#) [ADP1740-1.5-EVALZ](#) [ADP1752-1.5-EVALZ](#) [ADP1828LC-EVALZ](#) [ADP1870-0.3-EVALZ](#) [ADP1871-0.6-EVALZ](#) [ADP1873-0.6-EVALZ](#) [ADP1874-0.3-EVALZ](#) [ADP1882-1.0-EVALZ](#) [ADP199CB-EVALZ](#) [ADP2102-1.25-EVALZ](#) [ADP2102-1.875EVALZ](#) [ADP2102-1.8-EVALZ](#) [ADP2102-2-EVALZ](#) [ADP2102-3-EVALZ](#) [ADP2102-4-EVALZ](#) [ADP2106-1.8-EVALZ](#) [ADP2147CB-110EVALZ](#) [AS3606-DB](#) [BQ24010EVM](#) [BQ24075TEVM](#) [BQ24155EVM](#) [BQ24157EVM-697](#) [BQ24160EVM-742](#) [BQ24296MEVM-655](#) [BQ25010EVM](#) [BQ3055EVM](#) [NCV891330PD50GEVB](#) [ISLUSBI2CKIT1Z](#) [LM2744EVAL](#) [LM2854EVAL](#) [LM3658SD-AEV/NOPB](#) [LM3658SDEV/NOPB](#) [LM3691TL-1.8EV/NOPB](#) [LM4510SDEV/NOPB](#) [LM5033SD-EVAL](#) [LP38512TS-1.8EV](#) [EVAL-ADM1186-1MBZ](#) [EVAL-ADM1186-2MBZ](#)