

## LTC6404-x, LTC6406, LTC6405 and LTC6403-1 16-Bit Differential ADC Drivers

### DESCRIPTION

Demonstration circuit 1147 features the LTC6404-x, LTC6406, LTC6403-1, and LTC6405 16-bit ADC Drivers. It incorporates a variety of passive components to support configurations for varied applications. Single-ended or differential input and output configurations are possible, and there is a calibration circuit to null out the effects of other circuit components.

The LTC640x are high-speed differential amplifiers with superior distortion and noise performance, perfect for demanding communications transceivers, cellular base-stations, and other high-speed signal chain applications.

These fully-differential amplifiers accept single-ended or differential inputs with almost no difference in distortion performance. Each part has the ability to independently adjust the output common-mode voltage without any additional components, and flexible input common-mode ranges which enable level-shifting of input signals for ADC driving applications.

**Design files for this circuit board are available. Call the LTC factory.**

 , LTC and LT are registered trademarks of Linear Technology Corporation.

### QUICK START PROCEDURE

Table 1 shows the function of each SMA connector on the board. Refer to Figure 1 for the connection diagram and follow the procedure below:

1. Connect the power supply as shown. The power labels of V+, VOVM, and GND directly correspond to the power supply and VOVM pins of the LTC640x ICs (U1). Jumper JP1 enables or shuts down the amplifier.
2. The power supplies available for each part are shown in Table 1. **Do not exceed the maximum power supply voltage for the parts.**
3. Apply an input signal to J1. A low-distortion, low noise signal source with an external high-order filter will yield the best performance. DC1147's input is impedance-matched to 50Ω; no external termination is necessary.
4. Observe the output via J3. The output is impedance-matched to 50Ω, suitable for the input of a network or spectrum analyzer.

**Table 1: DC1147 Board I/O Descriptions**

CONNECTOR	FUNCTION
J1 (IN+)	Differential Input. Use this connector to supply an input to the DC1147. Drive from a 50ohm signal source, no external termination necessary.
J2 (OUT-)	Differential Output. <b>Not connected by default.</b> Resistor R9 can be installed and R10 removed to receive the output signal differentially.
J3 (OUT+)	Output. Impedance-matched to 50 ohms, can be used to drive a 50ohm network/spectrum analyzer input.
J4 (IN-)	Differential Input. <b>Not connected by default.</b> Resistor R24 can be installed and R27 removed for differential input drive. R4 and R7 should be matched or both removed to provide a balanced input impedance.
JP1 (SHDN)	Shutdown jumper. The left (EN) position enables the part, while the right (DIS) puts it into shutdown mode.
E3 (VOVM)	Output Common-Mode Adjust. <b>By default, this pin is self-biasing within U1.</b> Override this voltage with any DC voltage source.
E5 (VTIP)	Corresponds to the VTIP pin in DC1147-D (LTC6405/6). Consult the datasheet for pin function. Leave floating if unused. This pin is not connected for all the other parts in the family.

# DEMO CIRCUIT DC1147 QUICK START GUIDE

## LOW NOISE/DISTORTION 16-BIT DIFFERENTIAL ADC DRIVERS

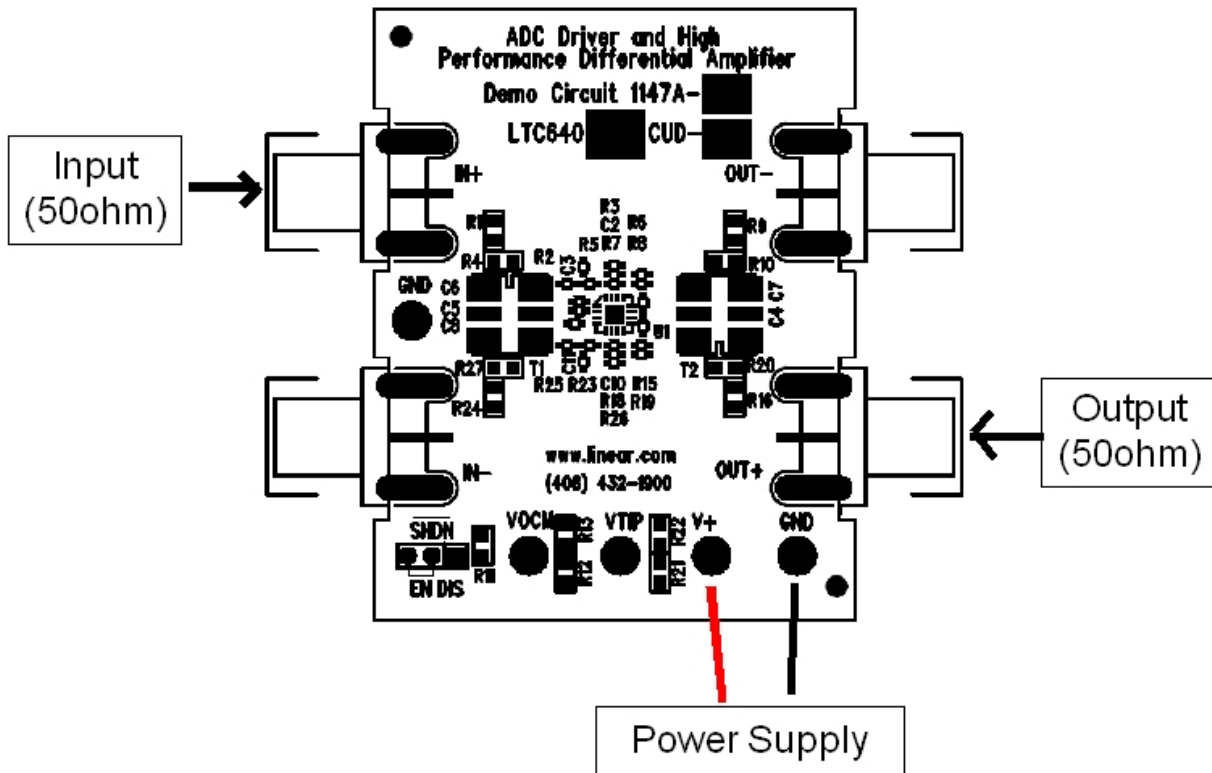

Figure 1: Proper Measurement Equipment Setup

### ADDITIONAL INFORMATION

Although the DC1147 demo board is ready to use out of the box, it has features that you can access by adding, removing or changing components on the board. These are described below.

#### DEMO BOARD VERSIONS

DC1147 has four versions to support all of the pin-compatible parts in the LTC640x amplifier family. Table 1 contains a listing of the different amplifiers and their supply voltage ranges. See the schematic (on the last page of this guide) for component differences between the versions.

#### DEMO BOARD SUPPLY VOLTAGES

Table 2: DC1147 Supply Voltages

DEMO BOARD	U1	SUPPLY VOLTAGE RANGE
DC1147A-A	LTC6404-1	2.7-5.25V
DC1147A-B	LTC6404-2	2.7-5.25V

DC1147A-C	LTC6404-4	2.7-5.25V
DC1147A-D	LTC6406	2.7-3.5V
DC1147A-E	LTC6403-1	2.7-5.25V
DC1147A-F	LTC6405	2.7-5.25V

#### DIFFERENTIAL INPUTS

To drive the inputs differentially, remove resistor R27 and install R24. J1 and J4 can now be driven differentially from a 50Ω signal source. R4 and R7 should be changed to differentially match the input to 50Ω if necessary.

#### DRIVING THE INPUTS DC-COUPLED

It is possible to drive the DC1147 inputs differentially with DC coupling. Transformer T1 should be replaced with 0Ω resistors. The inputs are now DC-coupled and can be driven single-ended or differentially (resistor values may be changed to balance the source impedances, et cetera. See

# DEMO CIRCUIT DC1147 QUICK START GUIDE

## LOW NOISE/DISTORTION 16-BIT DIFFERENTIAL ADC DRIVERS

---

the product datasheets for more information. Input bias currents will flow through the amplifier's input resistors if DC1147 is driven DC coupled.

### DIFFERENTIAL OUTPUTS

To use the both outputs of the DC1147, remove resistor R10 and install R9. The output now appears differentially across J3 and J2. The output of the DC1147 will still be matched to 50 $\Omega$  (differentially) when used in this manner.

### CHANGING THE OUTPUT COMMON-MODE VOLTAGE

Turret E3 controls the output common-mode voltage of U1. This function can be used to level-shift the DC output voltage for optimum system performance. If used for this purpose, transformer T2 can be replaced by 0 $\Omega$  resistors to allow the DC bias to reach the output. By default, the VOCM voltage is self-biased through resistors internal to the IC's (U1).

### OUTPUT DRIVE

Since the output of the LTC6400/1 is a low-impedance operational amplifier output, performance will degrade when the output is directly driving low impedances such as 50 $\Omega$ . On DC1147 there are series 100 ohms resistors at the output as well as a 4:1 transformer to increase the load impedance seen by the amplifier.

### ENABLE (SHUTDOWN)

Jumper JP1 controls the enable function of DC1147. When set to the EN position, the part will be on and draw quiescent current. In the DIS position, the part will be in shutdown and draw a very small amount of quiescent current.

### GROUND AND VCC CONNECTIONS

DC1147's GND connector is not only connected to V- of the LTC640x, it also serves as the board ground. For best performance, a low-impedance return path to the power supply from GND is crucial. Short, low impedance wires to the V+ and GND connectors of DC1147 will yield the best performance from the LTC6400/1.

### SCHEMATIC NOTES

Note that transformer T2 and the series resistors at the amplifier outputs create a 12.6dB attenuation (if the output has a 50 $\Omega$  load) that will affect the measured gain of the demo board. This is done so that the output of DC1147 can plug directly into a 50 $\Omega$  network/spectrum analyzer input, but the amplifier sees a higher 400 $\Omega$  load impedance.

# DEMO CIRCUIT DC1147 QUICK START GUIDE

## LOW NOISE/DISTORTION 16-BIT DIFFERENTIAL ADC DRIVERS

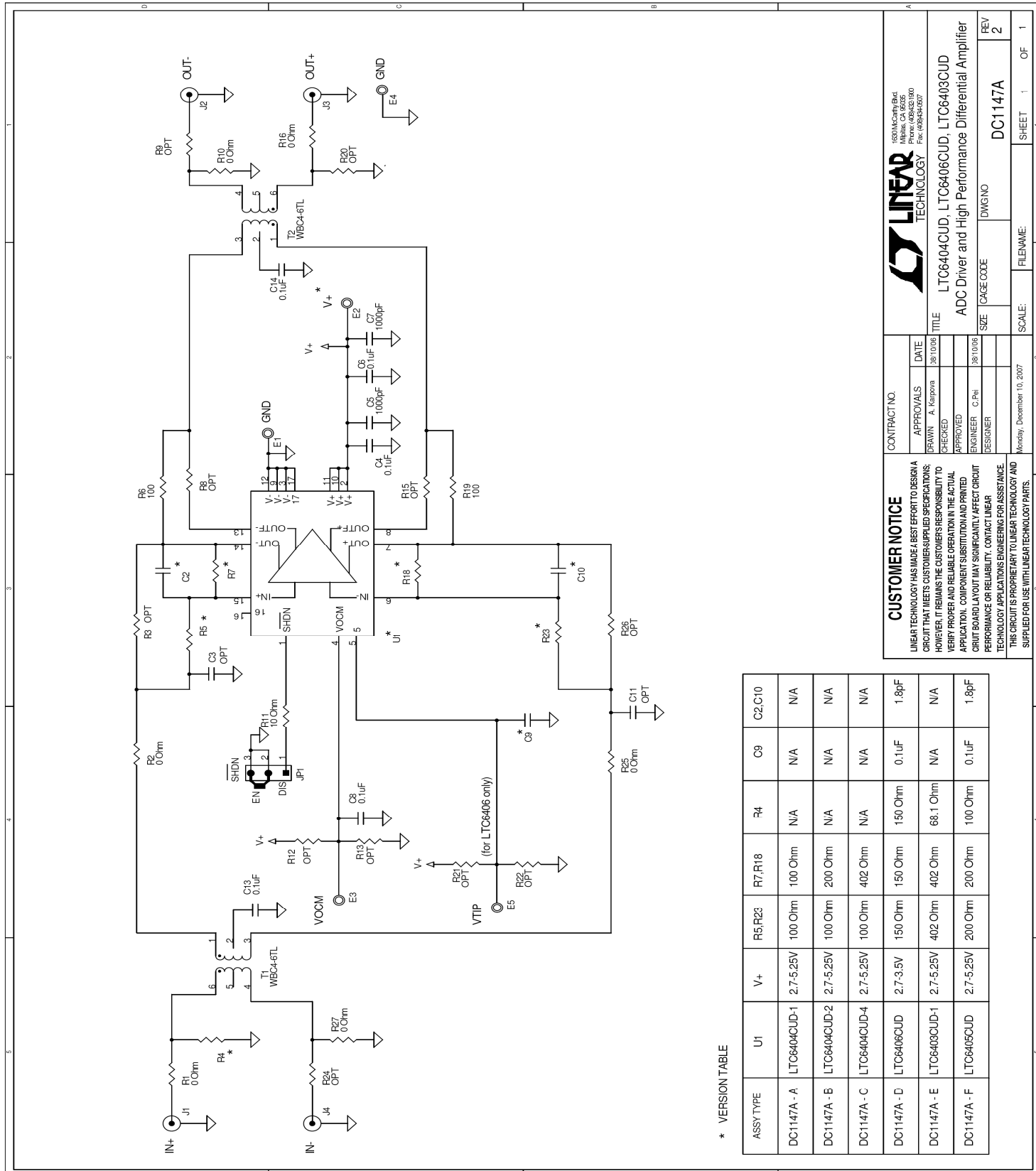

\* VERSION TABLE

ASSY TYPE	U1	V+	R5,R23	R4	C9	C2,C10
DC1147A - A	LTC6404CUD-1	2.7-5.25V	100 Ohm	N/A	N/A	N/A
DC1147A - B	LTC6404CUD-2	2.7-5.25V	200 Ohm	N/A	N/A	N/A
DC1147A - C	LTC6404CUD-4	2.7-5.25V	402 Ohm	N/A	N/A	N/A
DC1147A - D	LTC6406CUD	2.7-3.5V	150 Ohm	150 Ohm	0.1uF	1.8pF
DC1147A - E	LTC6403CUD-1	2.7-5.25V	402 Ohm	68.1 Ohm	N/A	N/A
DC1147A - F	LTC6405CUD	2.7-5.25V	200 Ohm	200 Ohm	0.1uF	1.8pF

### CUSTOMER NOTICE

LINEAR TECHNOLOGY HAS MADE A BEST EFFORT TO DESIGN A CIRCUIT THAT MEETS CUSTOMER-SUPPLIED SPECIFICATIONS; HOWEVER, IT REMAINS THE CUSTOMER'S RESPONSIBILITY TO VERIFY PROPER AND RELIABLE OPERATION IN THE ACTUAL APPLICATION. COMPONENT SUBSTITUTION AND PRINTED CIRCUIT BOARD LAYOUT THAT SIGNIFICANTLY AFFECT CIRCUIT PERFORMANCE OR RELIABILITY, CONTACT LINEAR TECHNOLOGY APPLICATIONS ENGINEERING FOR ASSISTANCE. THIS CIRCUIT IS PROPRIETARY TO LINEAR TECHNOLOGY AND SUPPLIED FOR USE WITH LINEAR TECHNOLOGY PARTS.

### CONTRACT NO.

APPROVALS	DATE
DRAWN: A. Karpova	3/8/10/06
CHECKED:	
APPROVED:	
ENGINEER: C. Pei	3/8/10/06
DESIGNER:	



16041 McCarty Rd.  
Milpitas, CA 95035  
Phone: (408) 432-1300  
Fax: (408) 432-1307

TITLE	SIZE	SCALE	FILENAME	SHEET	OF
LTC6404CUD, LTC6406CUD, LTC6403CUD ADC Driver and High Performance Differential Amplifier	DWGNO	1	DC1147A	1	1
REV					
2					

## X-ON Electronics

Largest Supplier of Electrical and Electronic Components

*Click to view similar products for [Data Conversion IC Development Tools](#) category:*

*Click to view products by [Analog Devices](#) manufacturer:*

Other Similar products are found below :

[EVAL-AD5063EBZ](#) [EVAL-AD5422LFEBZ](#) [EVAL-AD7265EDZ](#) [EVAL-AD7641EDZ](#) [EVAL-AD7674EDZ](#) [EVAL-AD7719EBZ](#) [EVAL-AD7767-1EDZ](#) [EVAL-AD7995EBZ](#) [AD9114-DPG2-EBZ](#) [AD9211-200EBZ](#) [AD9251-20EBZ](#) [AD9251-65EBZ](#) [AD9255-125EBZ](#) [AD9284-250EBZ](#) [AD9613-170EBZ](#) [AD9627-125EBZ](#) [AD9629-20EBZ](#) [AD9709-EBZ](#) [AD9716-DPG2-EBZ](#) [AD9737A-EBZ](#) [AD9787-DPG2-EBZ](#) [AD9993-EBZ](#) [DAC8555EVM](#) [ADS5482EVM](#) [ADS8372EVM](#) [EVAL-AD5061EBZ](#) [EVAL-AD5062EBZ](#) [EVAL-AD5443-DBRDZ](#) [EVAL-AD5570SDZ](#) [EVAL-AD7450ASDZ](#) [EVAL-AD7677EDZ](#) [EVAL-AD7992EBZ](#) [EVAL-AD7994EBZ](#) [AD9119-MIX-EBZ](#) [AD9148-M5375-EBZ](#) [AD9204-80EBZ](#) [AD9233-125EBZ](#) [AD9265-105EBZ](#) [AD9265-80EBZ](#) [AD9608-125EBZ](#) [AD9629-80EBZ](#) [AD9648-125EBZ](#) [AD9649-20EBZ](#) [AD9650-80EBZ](#) [AD9765-EBZ](#) [AD9767-EBZ](#) [AD9778A-DPG2-EBZ](#) [ADS8322EVM](#) [LM96080EB/NOPB](#) [EVAL-AD5445SDZ](#)