

LTC3860EUH DUAL OUTPUT SYNCHRONOUS BUCK CONVERTER

DESCRIPTION

Demonstration circuit DC1184A is a dual output voltage mode synchronous buck converter featuring the LTC3860EUH. This board provides two outputs of 1.2V/25A and 1.8V/25A from an input voltage of 10V to 14V at a switching frequency of 500kHz. The power stage consists of the Renesas R2J20602NP which is a tri-state PWM compatible 8mm x 8mm DrMOS and a 0.47uH 13.2mm x 12.8mm iron powder type inductor from Würth. An on-board 5V LT1616 buck regulator provides the 5V bias for the LTC3860 and the DrMOS.

The demo board uses a high density, two sided drop-in layout. The power components, excluding the bulk output and input capacitors, fit within a 1.5" x 1.25" area on the top layer. The control circuit resides in a 0.75" x 0.75" area on the bottom layer. The package style for the LTC3860EUH is a 32-lead 5mm x 5mm QFN.

The main features of the board are listed below:

- Differential amplifier for remote sensing V_{OUT1} which is setup for 1.2V.
- Optional components for single output dual phase operation.
- CLKIN pin for synchronization to an external clock which can be used in conjunction with optional PHSMD resistors and CLKOUT pin for up to 12-phase operation.
- TRACK/SS pins for external coincident rail tracking.
- RUN pins and PGOOD pins for each phase.
- For each phase, optional footprints for an LTC4449 gate driver and two top FETs and two bottom FETs.

Design files for this circuit board are available. Call the LTC factory.

Table 1. Performance Summary ($T_A = 25^\circ\text{C}$)

| PARAMETER | CONDITION | VALUE |
|-----------------------------|---|--------------------------|
| Minimum Input Voltage | | 10V |
| Maximum Input Voltage | | 14V |
| Output Voltage V_{OUT1} | $I_{OUT1} = 0\text{A TO } 25\text{A}, V_{IN} = 10\text{V to } 14\text{V}$ | $1.2\text{V} \pm 1.75\%$ |
| Output Voltage V_{OUT2} | $I_{OUT2} = 0\text{A TO } 25\text{A}, V_{IN} = 10\text{V to } 14\text{V}$ | $1.8\text{V} \pm 1.75\%$ |
| Nominal Switching Frequency | | 500kHz |
| Efficiency | $V_{OUT1} = 1.2\text{V}, I_{OUT1} = 25\text{A}, V_{IN} = 12\text{V}$ | 87.8% typical |
| See Figure 2 | $V_{OUT2} = 1.8\text{V}, I_{OUT2} = 25\text{A}, V_{IN} = 12\text{V}$ | 91.0% typical |

QUICK START PROCEDURE

Demonstration circuit 1184A is easy to set up to evaluate the performance of the LTC3860EUH. Refer to Figure 1 for the proper measurement equipment setup and follow the procedure below:

1. Place jumpers in the following positions:

| | | |
|------------|-------------------|------------|
| JP1 | RUN1 | ON |
| JP2 | RUN2 | ON |
| JP3 | INT 5V | ON |
| JP4 | +5V SELECT | INT |

2. With power off, connect the input power supply to VIN and GND. Turn on the power at the input and increase the input voltage to 10V or higher.
3. Check for the proper output voltages:
Vout1 = 1.179V to 1.221V
Vout2 = 1.769V to 1.832V

4. Once the proper output voltages are established, adjust the loads within the operating range and observe the output voltage regulation, ripple voltage, efficiency and other parameters.

Note 1. Do not apply load between the VOS1+ and VOS1- pins or between the VO2+ and VO2- pins. These pins are only intended to sense the output voltage across COUT4 and COUT10 respectively. Heavy load currents applied across these pins may damage the converter.

Note 2. Use J9 and J10 to monitor the output voltage ripple. J9 will measure the ripple across COUT2 and J10 will measure the ripple across COUT8. Connect J9 and J10 to the oscilloscope with a short coaxial cable. To avoid excessive noise pickup, keep the length of the cable to a minimum.

SINGLE OUTPUT / DUAL PHASE OPERATION

A single output / dual phase converter may be preferred for high output current applications. The benefits of single output / dual phase operation is lower ripple current through the input and output capacitors, improved load step response and simplified thermal design. To implement single output / dual phase operation, make the following modifications:

1. Select phase 1 to be the master and phase 2 the slave since the differential amplifier already senses V_{OUT1} .
2. Stuff R16 with 0 Ohms to disable the error amp for phase 2.
3. Stuff 0 Ohms at R49 to tie COMP1 to COMP2 and remove the redundant compensation components.
4. Stuff R20 with 0 Ohms.
5. Remove 0 Ohm resistor at R25 to release IAVG from ground.
6. Stuff C16 with 100pF to filter the IAVG signal.

7. Stuff R60 with 0 Ohms to tie the two RUN pins together.
8. Stuff R57 with 0 Ohms to tie the two TRK/SS pins together.
9. Tie VOUT1 to VOUT2 by tying together the exposed copper pads on the VOUT shapes with pieces of heavy copper foil.

LTC3860EUH

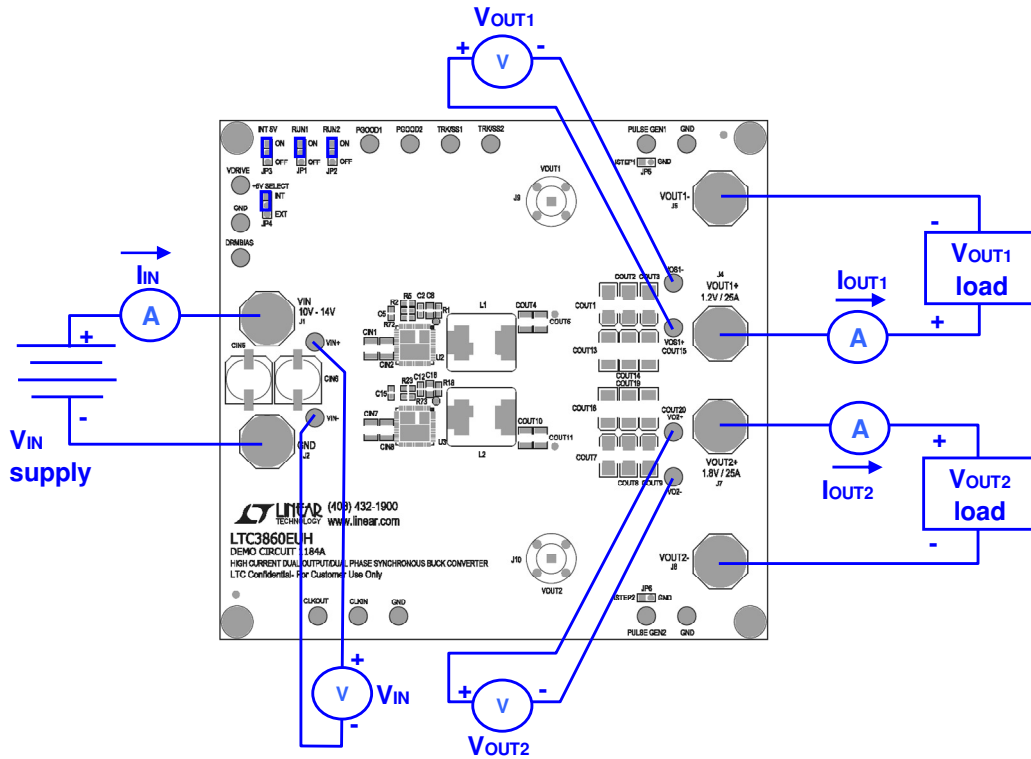

Figure 1. Proper Measurement Equipment Setup

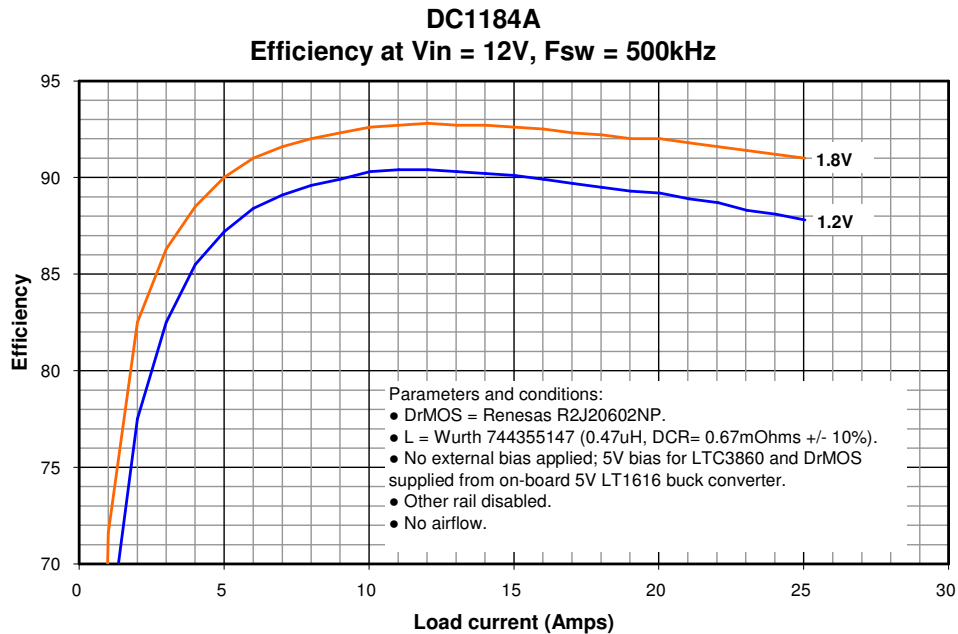
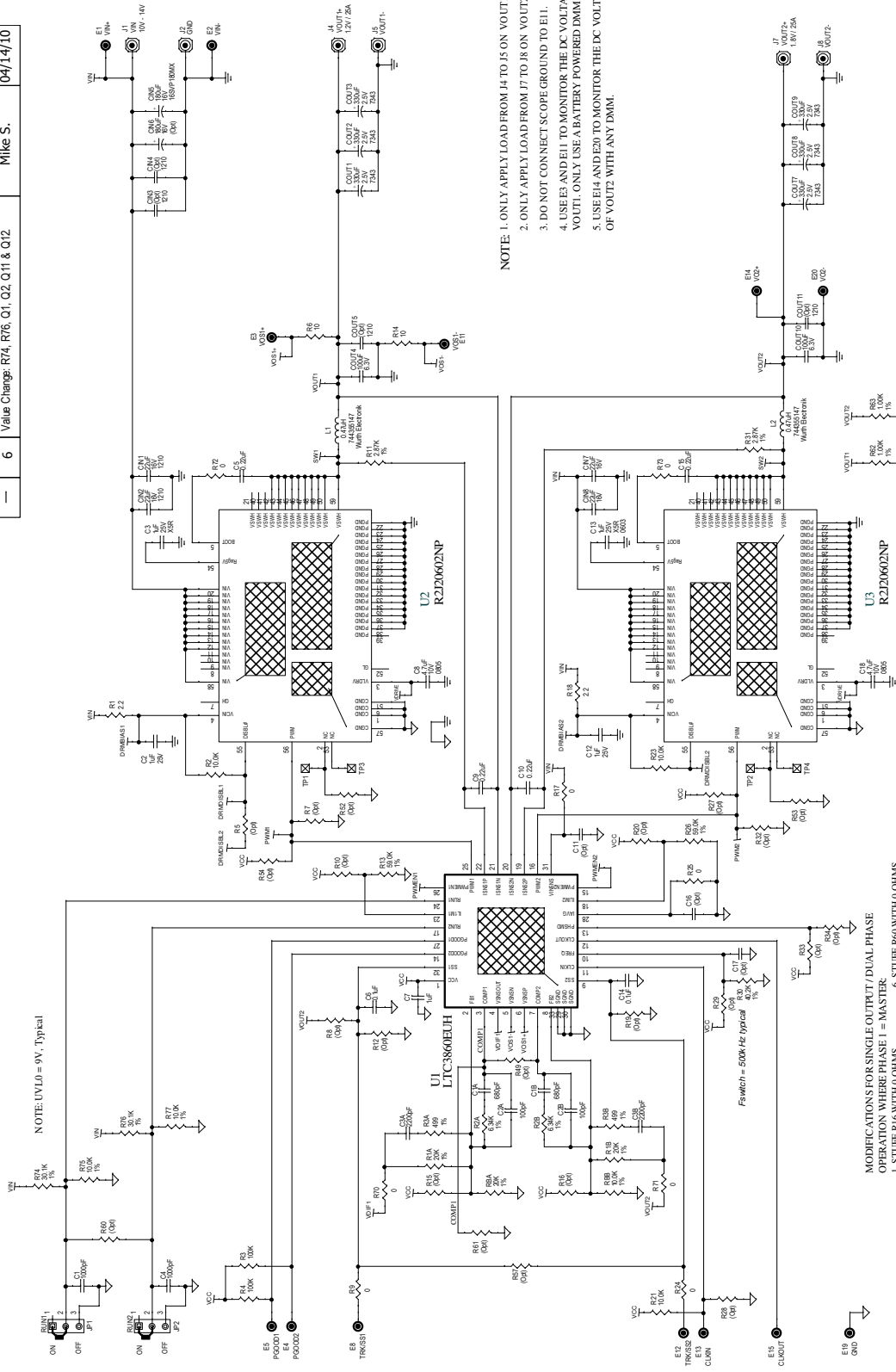

Figure 2. Typical Efficiency Curves

LTC3860EUH

| REVISION HISTORY | | | |
|------------------|-----|---|----------|
| ECO | REV | DESCRIPTION | DATE |
| - | 4 | PRODUCTION | 06/22/09 |
| - | 5 | Value Change: R2A, R2B, R30, R26, R13, COUT17, COUT22, C30 & C31. (ES with 400kHz @ 500kHz) | 01/11/10 |
| - | 6 | Value Change: R74, R76, Q1, Q2, Q11 & Q12 | 04/14/10 |



- NOTE: 1. ONLY APPLY LOAD FROM J4 TO J5 ON VOUT1.
 2. ONLY APPLY LOAD FROM J7 TO J8 ON VOUT2.
 3. DO NOT CONNECT SCOPE GROUND TO E1.
 4. USE E3 AND E11 TO MONITOR THE DC VOLTAGE OF VOUT1. ONLY USE A BATTERY POWERED DMM.
 5. USE E14 AND E20 TO MONITOR THE DC VOLTAGE OF VOUT2 WITH ANY DMM.

- NOTE: UNLESS OTHERWISE SPECIFIED,
 1. ALL RESISTORS ARE IN OHMS. 0603.
 2. ALL CAPACITORS ARE IN MICROFARAD. 0603.

- MODIFICATIONS FOR SINGLE OUTPUT / DUAL PHASE OPERATION WHERE PHASE 1 = MASTER:
 1. STUFF R16 WITH 0 OHMS.
 2. STUFF R49 WITH 0 OHMS.
 3. STUFF R57 WITH 0 OHMS.
 4. REMOVE R20 WITH 0 OHMS.
 5. STUFF C16 WITH 100PF.
 6. STUFF R60 WITH 0 OHMS.
 7. STUFF R57 WITH 0 OHMS.
 8. REMOVE REDUNDANT COMPENSATION COMPONENTS.
 9. TIE VOUT1 AND VOUT2 SHAPES TOGETHER.
- BODE PLOT SETUP:
 1. FOR VOUT1, APPLY EXCITATION SIGNAL ACROSS R6.
 2. FOR VOUT2, APPLY EXCITATION SIGNAL ACROSS R71 AND CHANGE ITS VALUE TO 10 OHMS.

NOTE: UVLO = 9V. Typical

Fswitch = 500kHz typical

OPTIONAL DISCRETE GATE DRIVER AND MOSFETS FOR PHASE 1

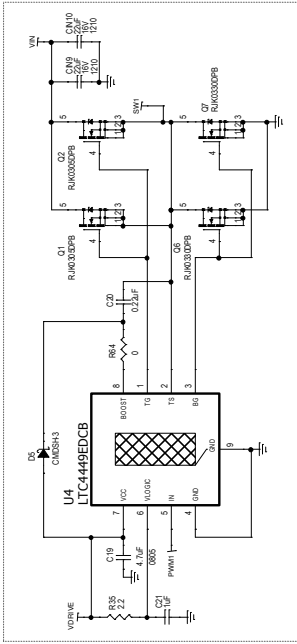

OPTIONAL DISCRETE GATE DRIVER AND MOSFETS FOR PHASE 2

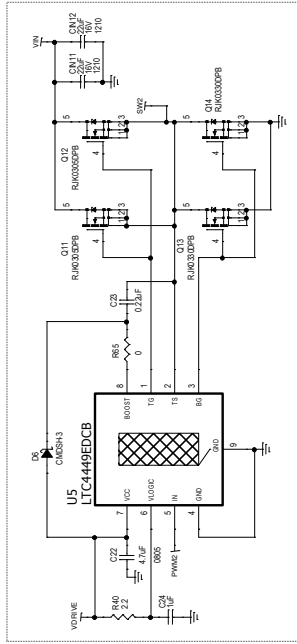

5V BIAS

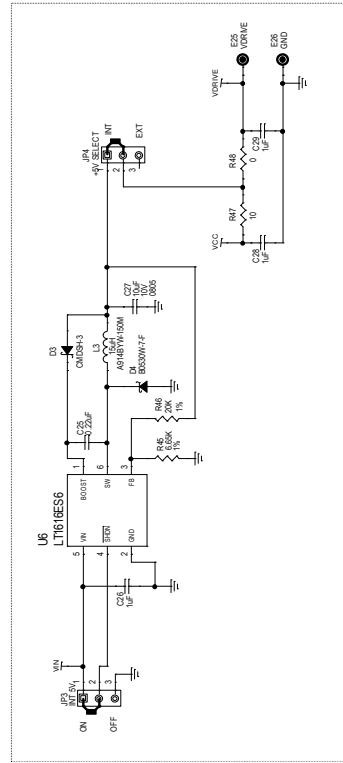

DYNAMIC LOAD CIRCUIT FOR VOUT1

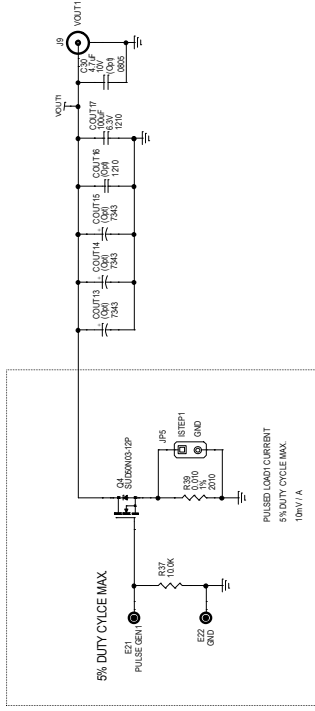

DYNAMIC LOAD CIRCUIT FOR VOUT2

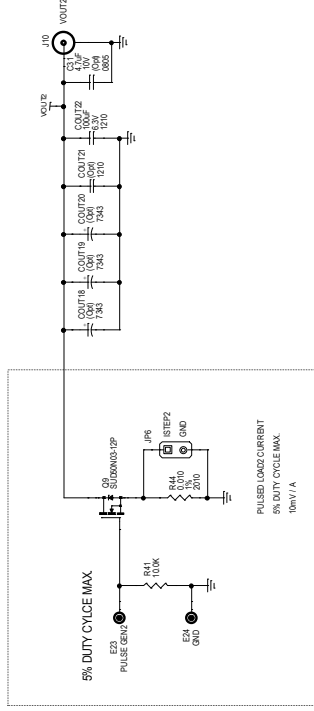

PWM ENABLE CIRCUIT FOR NON-THREE STATE COMPATIBLE DRMOs

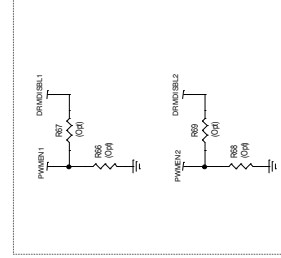

X-ON Electronics

Largest Supplier of Electrical and Electronic Components

Click to view similar products for [Power Management IC Development Tools](#) category:

Click to view products by [Analog Devices](#) manufacturer:

Other Similar products are found below :

[EVAL-ADM1168LQEBZ](#) [EVB-EP5348UI](#) [MIC23451-AAAYFL EV](#) [MIC5281YMME EV](#) [DA9063-EVAL](#) [ADP122-3.3-EVALZ](#) [ADP130-0.8-EVALZ](#) [ADP130-1.2-EVALZ](#) [ADP130-1.5-EVALZ](#) [ADP130-1.8-EVALZ](#) [ADP1714-3.3-EVALZ](#) [ADP1716-2.5-EVALZ](#) [ADP1740-1.5-EVALZ](#) [ADP1752-1.5-EVALZ](#) [ADP1828LC-EVALZ](#) [ADP1870-0.3-EVALZ](#) [ADP1871-0.6-EVALZ](#) [ADP1873-0.6-EVALZ](#) [ADP1874-0.3-EVALZ](#) [ADP1882-1.0-EVALZ](#) [ADP199CB-EVALZ](#) [ADP2102-1.25-EVALZ](#) [ADP2102-1.875EVALZ](#) [ADP2102-1.8-EVALZ](#) [ADP2102-2-EVALZ](#) [ADP2102-3-EVALZ](#) [ADP2102-4-EVALZ](#) [ADP2106-1.8-EVALZ](#) [ADP2147CB-110EVALZ](#) [AS3606-DB](#) [BQ24010EVM](#) [BQ24075TEVM](#) [BQ24155EVM](#) [BQ24157EVM-697](#) [BQ24160EVM-742](#) [BQ24296MEVM-655](#) [BQ25010EVM](#) [BQ3055EVM](#) [NCV891330PD50GEVB](#) [ISLUSBI2CKIT1Z](#) [LM2744EVAL](#) [LM2854EVAL](#) [LM3658SD-AEV/NOPB](#) [LM3658SDEV/NOPB](#) [LM3691TL-1.8EV/NOPB](#) [LM4510SDEV/NOPB](#) [LM5033SD-EVAL](#) [LP38512TS-1.8EV](#) [EVAL-ADM1186-1MBZ](#) [EVAL-ADM1186-2MBZ](#)