

## DESCRIPTION

Demonstration circuit 1193 is a triple output regulator consisting of three constant-frequency step-down converters integrated into LTC3545/-1. DC1193 has an input voltage range of 2.25V to 5.5V, with regulators capable of delivering 800mA of load current on each output. The three regulators operate independently with individual RUN pins and enter pulse skipping mode at low loads for reducing output ripple. In shutdown, the DC1193 draws less than 1 $\mu$ A total. The DC1193 is a very efficient circuit with efficiency reading above 90%. The LTC3545 comes in a 16-pin QFN package, which has an exposed pad on the bottom-side of the IC for better thermal performance. High

operating frequency of 2.25MHz allows exclusive use of the small size, low profile surface mount components. These features plus internal compensation circuits, make the DC1193 demo board an ideal circuit for use in battery-powered, hand-held applications. DC1193A-A is a demoboard for LTC3545 and DC1193A-B is a demoboard for LCT3545-1.

**Design files for this circuit board are available. Call the LTC factory.**

LTC is a trademark of Linear Technology Corporation

**Table 1.** Performance Summary ( $T_A = 25^\circ\text{C}$ )

PARAMETER	CONDITIONS	VALUE
Minimum Input Voltage		2.25V
Maximum Input Voltage		5.5V
Output Voltage Regulation VOUT1	$V_{IN} = 2.25\text{V to } 5.5\text{V}, I_{OUT} = 0\text{A to } 800\text{mA}$	1.8V $\pm$ 2%
Typical Output Ripple VOUT1	$V_{IN} = 4\text{V}, I_{OUT} = 800\text{mA}$ (20 MHz BW)	<15mV <sub>p-p</sub>
Output Voltage Regulation VOUT2	$V_{IN} = 2.25\text{V to } 5.5\text{V}, I_{OUT} = 0\text{A to } 800\text{mA}$	1.2V $\pm$ 2%
Typical Output Ripple VOUT2	$V_{IN} = 4\text{V}, I_{OUT} = 800\text{mA}$ (20 MHz BW)	<15mV <sub>p-p</sub>
Output Voltage Regulation VOUT3	$V_{IN} = 2.25\text{V to } 5.5\text{V}, I_{OUT} = 0\text{A to } 800\text{mA}$	1.5V $\pm$ 2%
Typical Output Ripple VOUT3	$V_{IN} = 4\text{V}, I_{OUT} = 800\text{mA}$ (20 MHz BW)	<15mV <sub>p-p</sub>
Nominal Switching Frequency		2.25 MHz

## QUICK START PROCEDURE

Demonstration Circuit 1193 is easy to set up to evaluate the performance of the LTC3545/-1. For proper measurement equipment configuration, set up the circuit according to the diagram in Figure 1.

NOTE: When measuring the input or output voltage ripple, care must be taken to avoid a long ground lead on the oscilloscope probe. Measure the input or output voltage ripple by touching the probe tip directly across the VIN or VOUT and GND terminals. See the Measurement Equipment Set-up diagram in Figure 2 for proper scope probe technique.

1. Connect the input power supply to the VIN and GND terminals. Connect the loads between the matching VOUT and GND terminals. Refer to Figure 1 for the proper measurement equipment setup. Make sure that loads on outputs VOUT1 to VOUT3 do not exceed 800mA, on each output (all three outputs can be loaded at the same time)
2. Apply 5V at VIN and then insert RUN jumper shunts JP1 through JP3 into the ON positions.
3. Measure all four outputs VOUT1 through VOUT3; they should read 1.8V, 1.2V and 1.5V correspondingly. All output voltages should be within +/- 2% tolerance.
4. Vary the input voltage from 5.5V to 2.25V; all four output voltages should be within +/- 2% tolerance.
5. Vary the VOUT1 load current from 0 to 800mA. Each output voltage should be within a tolerance of +/- 2%.
6. Vary the VOUT2 load currents from 0 to 800mA. Each output voltage should be within a tolerance of +/- 2%.
7. Vary the VOUT3 load current from 0 to 800mA. Each output voltage should be within a tolerance of +/- 2%.

8. To turn either output off set corresponding jumper into OFF position.

### For DC1193A-A only

To synchronize converter to external clock move jumper J4 to **Sync** position (contacts 1 and 2) and apply synchronization pulses in 1MHz to 3MHz frequency range to SYNC pin, see datasheet LTC3545 for details. For converter to operate in Pulse skipping mode move jumper J4 to **Pulse Skip** position (contacts 2 and 3). For converter to operate in Burst mode move jumper J4 into **Burst** position (contacts 3 and 4).

**Warning** - If the power for the demo board is carried in long leads, the input voltage at the part could “ring”, which could affect the operation of the converter. To eliminate the ringing, insert a small tantalum capacitor (for instance, AVX part # TAJW686M010) on the pads between the input power and return terminals on the bottom of the demo board. The (greater) ESR of the tantalum will dampen the (possible) ringing voltage due to the use of long input leads. On a normal, typical PCB, with short traces, the capacitor is not needed.

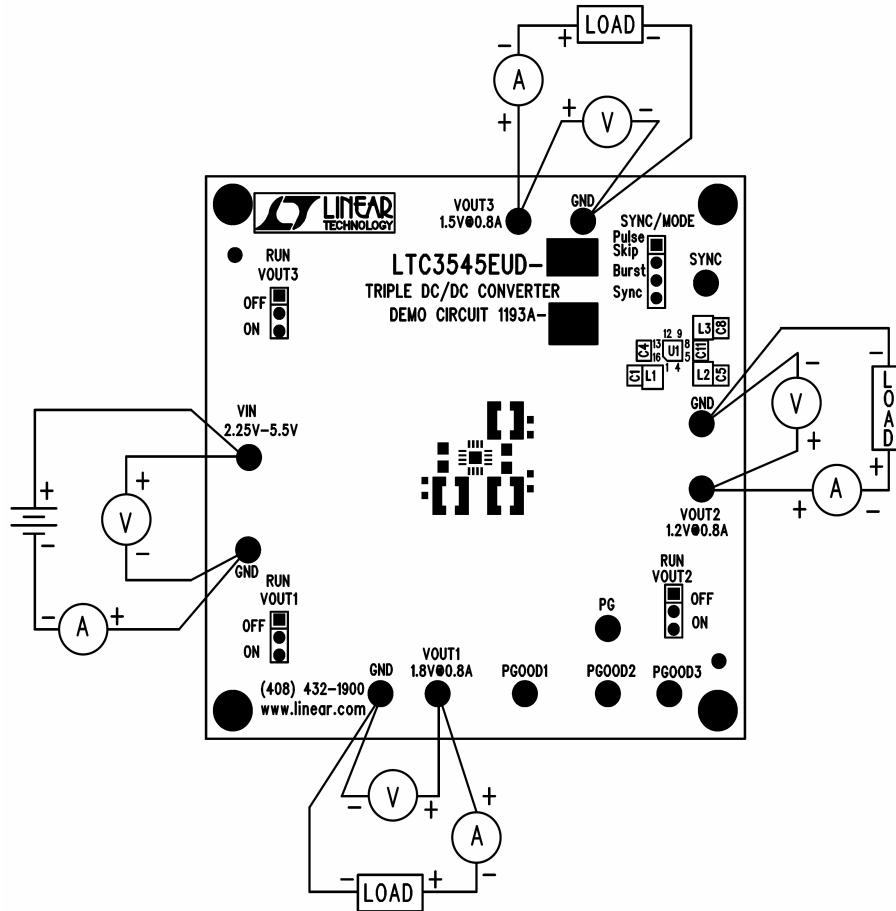

Figure 1. Proper Measurement Equipment Setup

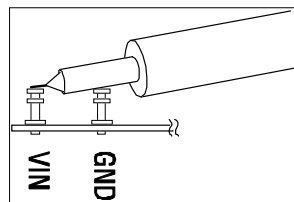
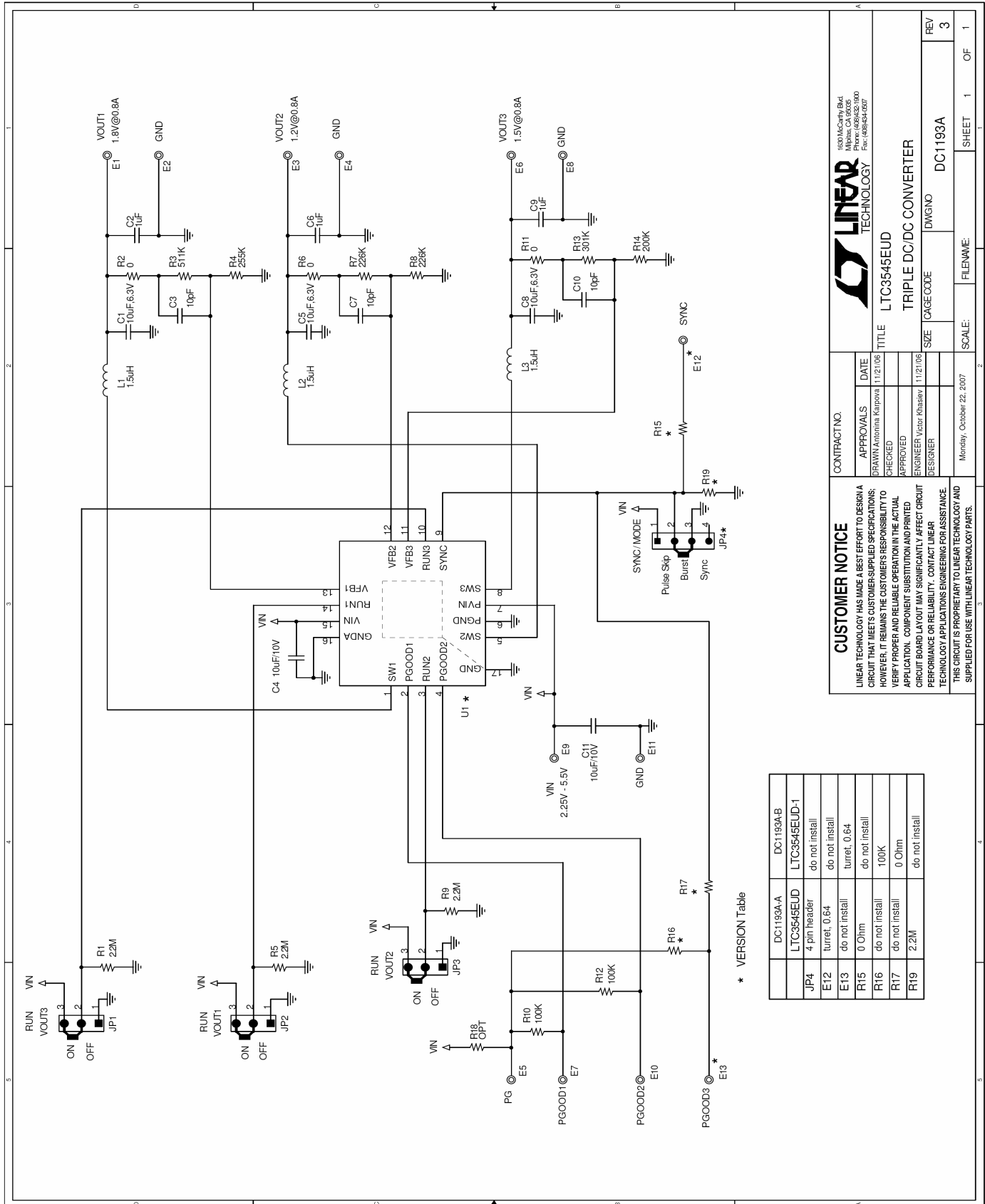

Figure 2. Measuring Input or Output Ripple

# QUICK START GUIDE FOR DEMONSTRATION CIRCUIT 1193

## TRIPLE DC/DC CONVERTER



**CUSTOMER NOTICE**  
 LINEAR TECHNOLOGY HAS MADE A BEST EFFORT TO DESIGN A CIRCUIT THAT MEETS ITS CUSTOMER-SUPPLIED SPECIFICATIONS; HOWEVER, IT REMAINS THE CUSTOMER'S RESPONSIBILITY TO VERIFY PROPER AND RELIABLE OPERATION IN THE ACTUAL APPLICATION. COMPONENT SUBSTITUTION AND PRINTED CIRCUIT BOARD LAYOUT MAY SIGNIFICANTLY AFFECT CIRCUIT PERFORMANCE OR RELIABILITY. CONTACT LINEAR TECHNOLOGY APPLICATIONS ENGINEERING FOR ASSISTANCE. THIS CIRCUIT IS PROPRIETARY TO LINEAR TECHNOLOGY AND SUPPLIED FOR USE WITH LINEAR TECHNOLOGY PARTS.

**CONTRACT NO.**  
 APPROVALS: [Signature] DATE: 11/2/06  
 DRAWN: Antonina Kalpova  
 CHECKED: [Signature]  
 APPROVED: [Signature]  
 ENGINEER: Victor Khaseyev  
 DESIGNER: [Signature]

**MONDAY, OCTOBER 22, 2007**

**\* VERSION Table**

DC1193A-A	DC1193A-B
LTC3545EUD	LTC3545EUD-1
JP4	4 pin header
E12	turret, 0.64
E13	do not install
R15	turret, 0.64
R16	do not install
R17	do not install
R19	do not install

**LINEAR TECHNOLOGY**  
 1680 McCarthy Blvd.  
 Fremont, CA 94533-0001  
 Phone: (408)433-1000  
 Fax: (408)434-1607

**LTC3545EUD**  
 TRIPLE DC/DC CONVERTER

SIZE: [ ] CASE CODE: [ ] DWGNO: DC1193A  
 SCALE: [ ] FILENAME: [ ] SHEET 1 OF 1

REV 3

## X-ON Electronics

Largest Supplier of Electrical and Electronic Components

*Click to view similar products for [Power Management IC Development Tools](#) category:*

*Click to view products by [Analog Devices](#) manufacturer:*

Other Similar products are found below :

[EVAL-ADM1168LQEBZ](#) [EVB-EP5348UI](#) [MIC23451-AAAYFL EV](#) [MIC5281YMME EV](#) [DA9063-EVAL](#) [ADP122-3.3-EVALZ](#) [ADP130-0.8-EVALZ](#) [ADP130-1.2-EVALZ](#) [ADP130-1.5-EVALZ](#) [ADP130-1.8-EVALZ](#) [ADP1714-3.3-EVALZ](#) [ADP1716-2.5-EVALZ](#) [ADP1740-1.5-EVALZ](#) [ADP1752-1.5-EVALZ](#) [ADP1828LC-EVALZ](#) [ADP1870-0.3-EVALZ](#) [ADP1871-0.6-EVALZ](#) [ADP1873-0.6-EVALZ](#) [ADP1874-0.3-EVALZ](#) [ADP1882-1.0-EVALZ](#) [ADP199CB-EVALZ](#) [ADP2102-1.25-EVALZ](#) [ADP2102-1.875EVALZ](#) [ADP2102-1.8-EVALZ](#) [ADP2102-2-EVALZ](#) [ADP2102-3-EVALZ](#) [ADP2102-4-EVALZ](#) [ADP2106-1.8-EVALZ](#) [ADP2147CB-110EVALZ](#) [AS3606-DB](#) [BQ24010EVM](#) [BQ24075TEVM](#) [BQ24155EVM](#) [BQ24157EVM-697](#) [BQ24160EVM-742](#) [BQ24296MEVM-655](#) [BQ25010EVM](#) [BQ3055EVM](#) [NCV891330PD50GEVB](#) [ISLUSBI2CKIT1Z](#) [LM2744EVAL](#) [LM2854EVAL](#) [LM3658SD-AEV/NOPB](#) [LM3658SDEV/NOPB](#) [LM3691TL-1.8EV/NOPB](#) [LM4510SDEV/NOPB](#) [LM5033SD-EVAL](#) [LP38512TS-1.8EV](#) [EVAL-ADM1186-1MBZ](#) [EVAL-ADM1186-2MBZ](#)