

# QUICK START GUIDE FOR DEMONSTRATION CIRCUIT 1208A LTC4151CDD HIGH VOLTAGE MONITOR WITH ADC AND I2C

## LTC4151CDD

## DESCRIPTION

Demonstration circuit 1208A features the LTC4151 high side power monitor that accepts input voltages from 7V to 80V. In default operation mode, the onboard 12-bit ADC continuously measures high side current, input voltage and an external voltage. Data is reported through the I2C interface when polled by a host. The monitors can also perform on-demand measurement in a snapshot mode. The LTC4151 features a dedicated shutdown pin to reduce power consumption.

DC1208A has jumpers on ADR1 and ADR0 to select one of nine distinct I2C addresses. A shut-

down jumper enables the LTC4151 or disables it into a low current shutdown state. I2C communication can be performed through the QuickEval system for evaluation of the part.

DC1208A can also be used in an assembly option with the LTC4151-1 which features split I2C data pins with data in and an inverted output to drive opto-isolators.

**Design files for this circuit board are available. Call the LTC factory.**

PowerPath is a trademark of Linear Technology Corporation

**Table 1. Typical DC1208A Performance Summary (T<sub>A</sub> = 25°C)**

PARAMETER	CONDITION	VALUE
Minimum Input Voltage	Voltage at VIN	7V
Maximum Input Voltage	LTC4151 Maximum Operating Input Voltage	80V
	DC1208 Maximum Operating VIN Voltage (Note 1)	75V
LTC4151 Supply Current	Shutdown JP3 on FLOAT	1mA
	Shutdown JP3 on LO	100µA
ADC Resolution		12 Bits
Full Scale Voltage	(SENSE+ – SENSE-)	81.92mV
	VIN	102.4V
	ADIN	2.048V
Full Scale Current	R1 (Sense) = 0.02Ω, I = (SENSE+ – SENSE-) / R1	4.096A
LSB Step Size	(SENSE+ – SENSE-)	20µV
	VIN	25mV
	ADIN	0.5mV

Note 1: DC1208 has a Transient Voltage Suppressor to assist with protection from voltages that can exceed absolute maximum voltages.

# QUICK START GUIDE FOR DEMONSTRATION CIRCUIT 1208A LTC4151CDD HIGH VOLTAGE MONITOR WITH ADC AND I2C

## QUICK START PROCEDURE

Demonstration circuit 1208A is easy to set up to evaluate the performance of the LTC4151. Refer to Figure 1 for proper measurement equipment setup and follow the procedure below:

1. Select I2C Address by setting JP1 and JP2.
2. Place jumper JP3 on FLOAT to enable the LTC4151.
3. Connect I2C master to SDA and SCL or connect QuickEval demonstration board to J1 through 14-pin ribbon cable and open software.
4. Connect the input power supply across VIN and GND.
5. Apply a load from VOUT to GND.
6. Apply a voltage at ADIN.
7. Read and write to the LTC4151 through I2C.

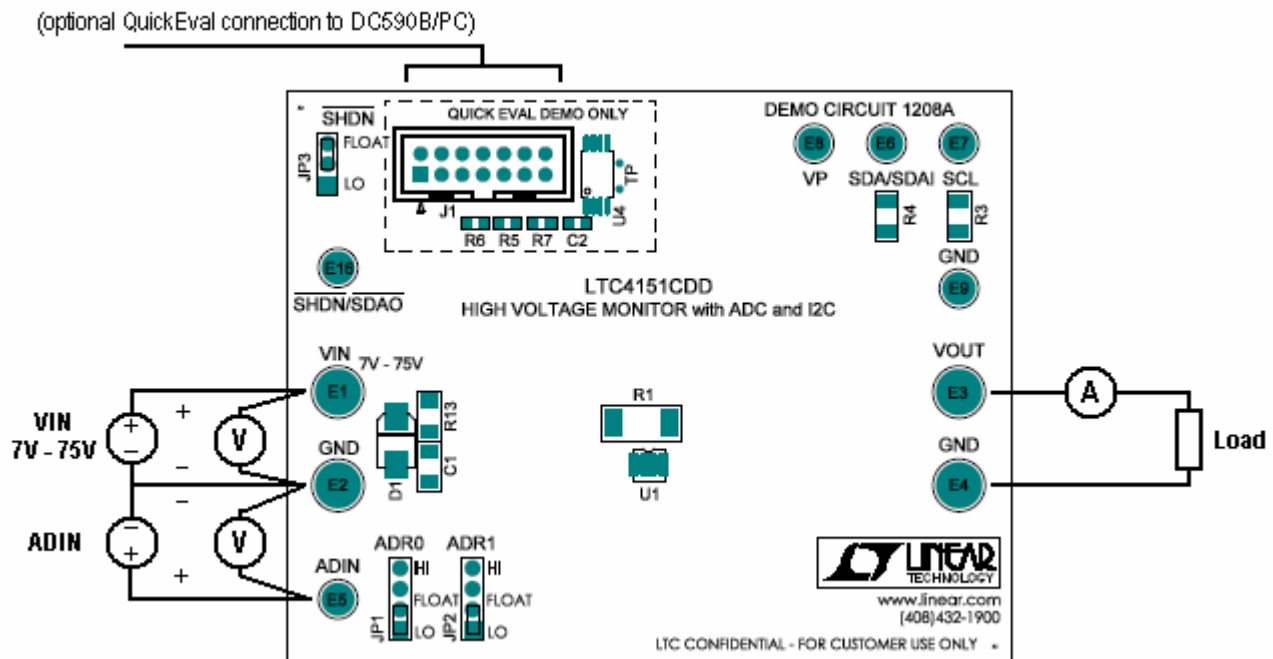

## ADDITIONAL INFORMATION

### ADDRESS

Nine distinct I2C bus addresses for the LTC4151/LTC4151-1 are configurable using the three-state pins ADR0 and ADR1. These are set on the DC1208A through JP1 and JP2. Refer to the address table shown in the LTC4151 data sheet. Address bits a6, a5, and a4 are configured to (110). In addition, the LTC4151/LTC4151-1 will respond to a mass write address (1100 110)b for writing to all LTC4151/ LTC4151-1s, regardless of their individual address settings.

### PROTECTION COMPONENTS

Components D1, C1 and R13 on the DC1208A are optional protection devices. These components protect the LTC4151 from an overvoltage during any ringing due to input turn on, inadvertent hot plug, or sudden extreme change in output load. When operating close to the maximum input voltage, the ringing without these components can exceed the absolute maximum voltage at the LTC4151 pins.

D1 provides a clamp selected with a maximum breakdown voltage below the absolute maximum rating of the LTC4151 VIN pin. The LTC4151 can operate up to 80V at VIN, but the zener diode limits the VIN supply voltage on the DC1208 to 75V. This helps protect against voltage spikes over 80V.

The RC provides a snubber circuit to assist in dampening and filtering any ringing that can occur. The RC values can be adjusted according to the application.

These protection components are optional in the end application if the input voltage is well below the absolute maximum and peak voltage due to spikes or ringing will not damage the LTC4151 or any other components connected to VIN.

### OPTO-ISOLATION (LTC4151-1 OPTION)

The DC1208 has parts placement pads for an opto-isolated I2C assembly option. The LTC4151-1 replaces the LTC4151 to provide separated /SDAO and SDAI pins that simplifies the opto-isolation. The LT3010 LDO powers on the LTC4151 side the high speed opto-couplers over the full input voltage range. Four 20k resistors in parallel on /SDAO distribute the power across this pull-up, enough for up to 80V at VIN.

On the isolated I2C side, the bus supply voltage is connected across ISO\_VP and ISO\_GND. Isolated I2C lines connected to ISO\_SDA and ISO\_SCL.

### I2C BUS PULL-UP

The LTC4151 I2C pull-up resistors on SDA and SCL are typically pulled up to the microcontroller supply. The SDA and SCL pins also have an internal 6V clamp that allow for I2C bus pull resistors to VIN. When selecting resistor values in the end application, take in to consideration maximum input voltage, resistor power rating, and resistor value to provide sufficient bus pull-up to meet I2C specification requirements. The same considerations apply to /SDAO with the LTC4151-1 option.

### QUICKEVAL

The QuickEval system provides a quick and easy I2C communication from a PC by connecting to the DC590B controller board though USB and to the DC1208A through a 14-pin ribbon cable. When the QuickEval software is opened and the demo board is connected, the software will identify the board and bring up the corresponding Graphical User Interface (GUI). When the demo board is disconnected the GUI is closed.

On the LTC4151 GUI, click on Auto Find to first find the LTC4151 address. Click on START to begin polling the LTC4151. SENSE, VIN, and ADIN

# QUICK START GUIDE FOR DEMONSTRATION CIRCUIT 1208A LTC4151CDD

## HIGH VOLTAGE MONITOR WITH ADC AND I2C

ADCs values are read in the left column. A Snapshot button for each ADC can be clicked on to perform on-demand measurement of the selected voltage. Register bits status are read in the registers section. Configurations can be done by checking the bits in the CONTROL register 'G'.

The QuickEval components are optional and used for evaluation purpose only on the demo board. These components are not needed in the final application and should not be included.

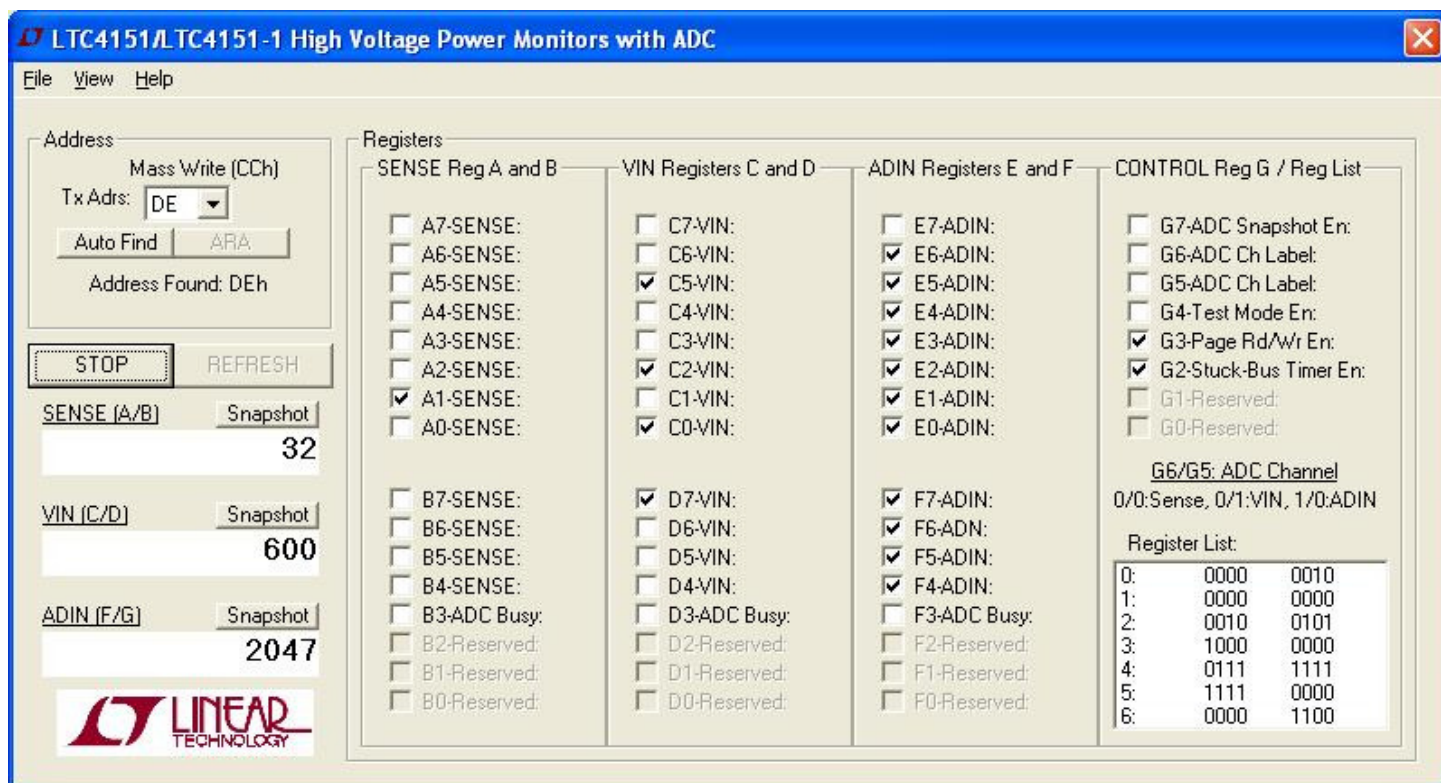

Figure 2. LTC4151 QuickEval Interface



## X-ON Electronics

Largest Supplier of Electrical and Electronic Components

*Click to view similar products for [Power Management IC Development Tools](#) category:*

*Click to view products by [Analog Devices](#) manufacturer:*

Other Similar products are found below :

[EVAL-ADM1168LQEBZ](#) [EVB-EP5348UI](#) [MIC23451-AAAYFL EV](#) [MIC5281YMME EV](#) [DA9063-EVAL](#) [ADP122-3.3-EVALZ](#) [ADP130-0.8-EVALZ](#) [ADP130-1.2-EVALZ](#) [ADP130-1.5-EVALZ](#) [ADP130-1.8-EVALZ](#) [ADP1714-3.3-EVALZ](#) [ADP1716-2.5-EVALZ](#) [ADP1740-1.5-EVALZ](#) [ADP1752-1.5-EVALZ](#) [ADP1828LC-EVALZ](#) [ADP1870-0.3-EVALZ](#) [ADP1871-0.6-EVALZ](#) [ADP1873-0.6-EVALZ](#) [ADP1874-0.3-EVALZ](#) [ADP1882-1.0-EVALZ](#) [ADP199CB-EVALZ](#) [ADP2102-1.25-EVALZ](#) [ADP2102-1.875EVALZ](#) [ADP2102-1.8-EVALZ](#) [ADP2102-2-EVALZ](#) [ADP2102-3-EVALZ](#) [ADP2102-4-EVALZ](#) [ADP2106-1.8-EVALZ](#) [ADP2147CB-110EVALZ](#) [AS3606-DB](#) [BQ24010EVM](#) [BQ24075TEVM](#) [BQ24155EVM](#) [BQ24157EVM-697](#) [BQ24160EVM-742](#) [BQ24296MEVM-655](#) [BQ25010EVM](#) [BQ3055EVM](#) [NCV891330PD50GEVB](#) [ISLUSBI2CKIT1Z](#) [LM2744EVAL](#) [LM2854EVAL](#) [LM3658SD-AEV/NOPB](#) [LM3658SDEV/NOPB](#) [LM3691TL-1.8EV/NOPB](#) [LM4510SDEV/NOPB](#) [LM5033SD-EVAL](#) [LP38512TS-1.8EV](#) [EVAL-ADM1186-1MBZ](#) [EVAL-ADM1186-2MBZ](#)