

1.1MHz, 500mA, Step-down Regulator in 2mmx2mm DFN

DESCRIPTION

Demo circuit DC1221B is a monolithic step-down DC/DC switching regulator featuring the LT3502. The demo circuit is designed for 3.3V output from a 4.5V to 40V input. The wide input range of the LT3502 allows a variety of input sources including automotive batteries and 24V industrial supplies. The high switching frequency allows the use of tiny, low cost external components. The current mode control scheme creates fast transient response and good loop stability. The boost diode is internal to reduce component count. The $\overline{\text{SHDN}}$ pin can also be used to program soft start. In this mode, the $\overline{\text{SHDN}}$ pin is driven through an external RC filter to create a voltage ramp on this pin. The soft start function reduces the input current surge during start-up. Cycle by cycle

current limit and frequency foldback provide the protection against shorted outputs. DA pin can further protect the silicon under fault conditions by sensing the diode current.

The LT3502 datasheet gives a complete description of the part, operation and application information. The datasheet must be read in conjunction with this quick start guide for demo circuit DC1221B.

Design files for this circuit board are available. Call the LTC factory.

 , LTC and LT are registered trademarks of Linear Technology Corporation.

Performance Summary ($T_A = 25^\circ\text{C}$)

PARAMETER	CONDITION	VALUE
Minimum Input Voltage		4.5V
Maximum Input Voltage		40V
Output Voltage V_{OUT}		3.328V $\pm 2.8\%$
Switching Frequency		1.1MHz $\pm 18\%$
Maximum Output Current		500mA
Efficiency	$V_{\text{IN}}=12\text{V}, I_{\text{OUT}}=500\text{mA}$	80%
Voltage Ripple	$V_{\text{IN}}=12\text{V}, I_{\text{OUT}}=500\text{mA}$	10mV

QUICK START PROCEDURE

Demonstration circuit 1221B is easy to set up to evaluate the performance of the LT3502. Refer to Figure 1 for proper measurement equipment setup and follow the procedure below:

NOTE . When measuring the input or output voltage ripple, care must be taken to avoid a long ground lead on the oscilloscope probe. Measure the input or output voltage ripple by touching the probe tip directly across the Vin or Vout and GND terminals. See Figure 2 for proper scope probe technique.

1. Place JP1 on the ON position.

2. With power off, connect the input power supply to Vin and GND.

3. Turn on the power at the input.

NOTE . Make sure that the input voltage does not exceed 40V.

4. Check for the proper output voltages.

NOTE . If there is no output, temporarily disconnect the load to make sure that the load is not set too high.

5. Once the proper output voltage is established, adjust the load within the operating range and observe the

LT3502

output voltage regulation, ripple voltage, efficiency and other parameters.

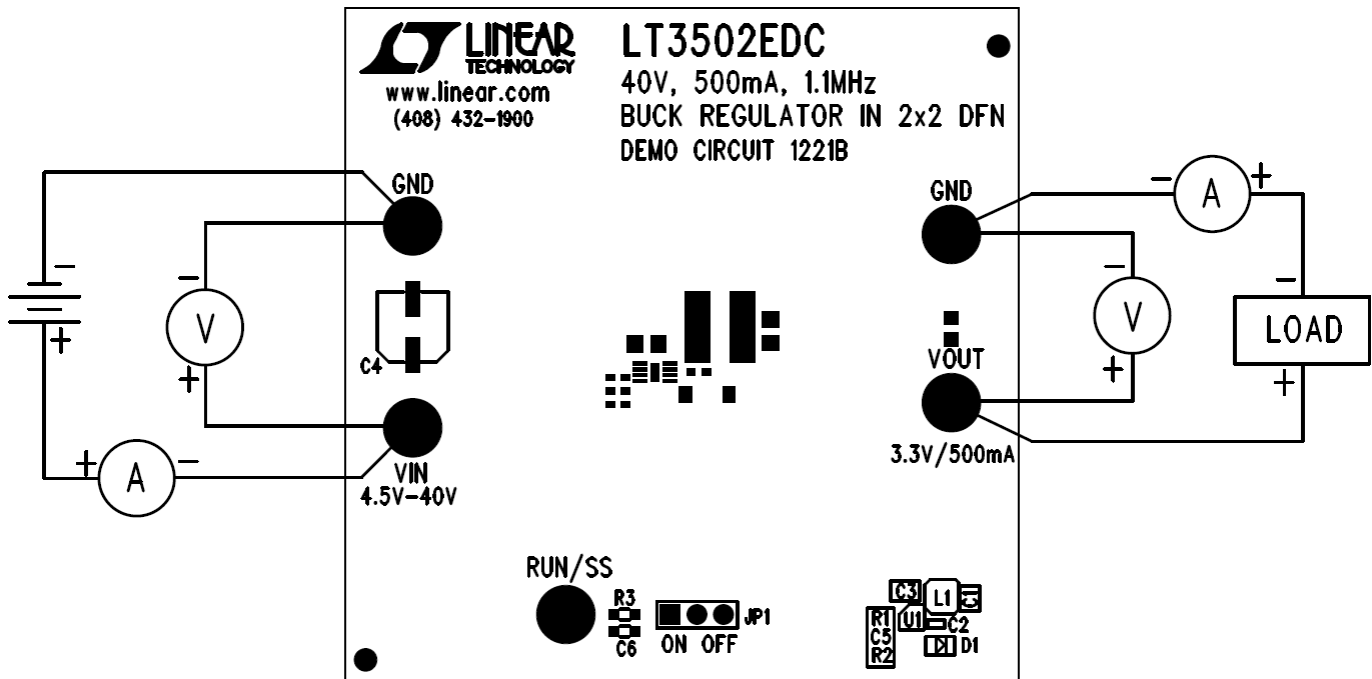

Figure 1. Proper Measurement Equipment Setup

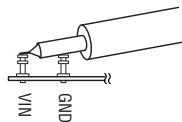
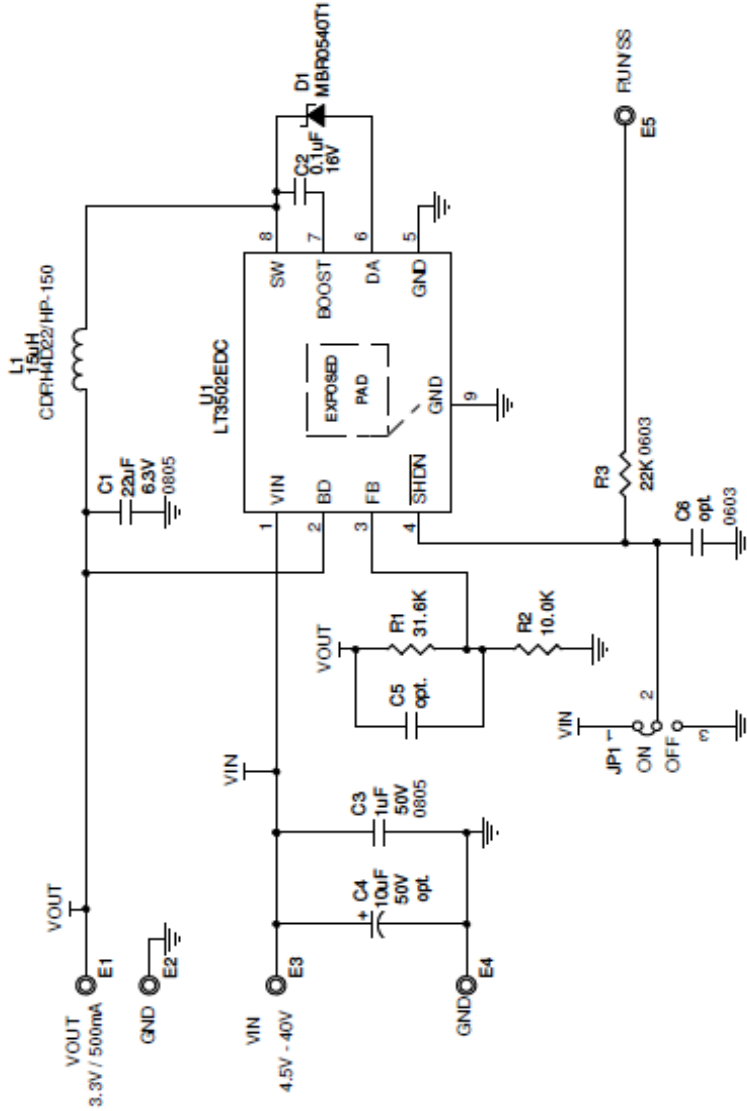

Figure 2. Measuring Input or Output Ripple

REVISION HISTORY				
ECO	REV	DESCRIPTION	APPROVED	DATE
-	1	PRODUCTION	MOLLYZ	04-05-10



NOTE: UNLESS OTHERWISE SPECIFIED

1. ALL RESISTORS ARE IN ΩΩZ.
2. ALL CAPACITORS ARE IN 040Z.
3. INSTALL SHUNTS AS SHOWN.

<p>CUSTOMER NOTICE</p> <p>LINEAR TECHNOLOGY HAS MADE A BEST EFFORT TO DESIGN A CIRCUIT THAT MEETS CUSTOMER-SUPPLIED SPECIFICATIONS; HOWEVER, IT REMAINS THE CUSTOMER'S RESPONSIBILITY TO VERIFY PROPER AND RELIABLE OPERATION IN THE ACTUAL APPLICATION. COMPONENT SUBSTITUTION AND PRINTED CIRCUIT BOARD LAYOUT MAY SIGNIFICANTLY AFFECT CIRCUIT PERFORMANCE OR RELIABILITY. CONTACT LINEAR TECHNOLOGY APPLICATIONS ENGINEERING FOR ASSISTANCE.</p>	<p>APPROVALS</p> <p>PCB DES. <i>JW</i></p> <p>APP. ENG. <i>MOLLYZ</i></p>	<p>SCALE = NONE</p>
	<p>LINEAR TECHNOLOGY</p> <p>1630 McCarthy Blvd. Milpitas, CA 95035 Phone: (408)432-1900 www.linear.com Fax: (408)434-0507 LTC Confidential For Customer Use Only</p>	<p>TITLE: SCHEMATIC</p> <p>40V, 500mA, 1.1MHz BUCK REGULATOR IN 2x2 DFN</p> <p>SIZE <i>N/A</i> IC NO. LT3502EDC</p>
<p>DATE: 04-05-10</p>		<p>SHEET 1 OF 1</p>

X-ON Electronics

Largest Supplier of Electrical and Electronic Components

Click to view similar products for [Power Management IC Development Tools](#) *category:*

Click to view products by [Analog Devices](#) *manufacturer:*

Other Similar products are found below :

[EVAL-ADM1168LQEBZ](#) [EVB-EP5348UI](#) [MIC23451-AAAYFL EV](#) [MIC5281YMME EV](#) [DA9063-EVAL](#) [ADP122-3.3-EVALZ](#) [ADP130-0.8-EVALZ](#) [ADP130-1.2-EVALZ](#) [ADP130-1.5-EVALZ](#) [ADP130-1.8-EVALZ](#) [ADP1714-3.3-EVALZ](#) [ADP1716-2.5-EVALZ](#) [ADP1740-1.5-EVALZ](#) [ADP1752-1.5-EVALZ](#) [ADP1828LC-EVALZ](#) [ADP1870-0.3-EVALZ](#) [ADP1871-0.6-EVALZ](#) [ADP1873-0.6-EVALZ](#) [ADP1874-0.3-EVALZ](#) [ADP1882-1.0-EVALZ](#) [ADP199CB-EVALZ](#) [ADP2102-1.25-EVALZ](#) [ADP2102-1.875EVALZ](#) [ADP2102-1.8-EVALZ](#) [ADP2102-2-EVALZ](#) [ADP2102-3-EVALZ](#) [ADP2102-4-EVALZ](#) [ADP2106-1.8-EVALZ](#) [ADP2147CB-110EVALZ](#) [AS3606-DB](#) [BQ24010EVM](#) [BQ24075TEVM](#) [BQ24155EVM](#) [BQ24157EVM-697](#) [BQ24160EVM-742](#) [BQ24296MEVM-655](#) [BQ25010EVM](#) [BQ3055EVM](#) [NCV891330PD50GEVB](#) [ISLUSBI2CKIT1Z](#) [LM2744EVAL](#) [LM2854EVAL](#) [LM3658SD-AEV/NOPB](#) [LM3658SDEV/NOPB](#) [LM3691TL-1.8EV/NOPB](#) [LM4510SDEV/NOPB](#) [LM5033SD-EVAL](#) [LP38512TS-1.8EV](#) [EVAL-ADM1186-1MBZ](#) [EVAL-ADM1186-2MBZ](#)