

DESCRIPTION

Demonstration Circuit DC1251A features the LTC6601-X series family of pin configurable, fully differential, 2nd order lowpass filter and amplifier.

There are two DC1251A boards: a DC1251A-A with an LTC6601-1 and a DC1251A-B with an LTC6601-2.

Typically an LTC6601-1 is the choice for most lowpass filter applications in a 5MHz to 27MHz cutoff frequency range and the LTC6601-2 is optimized for lower distortion and lower power applications.

The LTC6601-X is designed to make the implementation of high frequency fully-differential filtering functions very easy. A very low noise amplifier is surrounded by 8 precision matched resistors and 12 precision matched capacitors so that many 2nd order lowpass filter transfer functions can be configured by hard wiring pins.

Figure 1 shows the LTC6601-X block diagram with all the internal resistors and capacitors. On a DC1251A the LTC6601-X resistor and capacitor pins can be connected through 0603 resistor jumpers to configure the cutoff frequency and the passband gain. The LTC6601-1 or LTC6601-2 data sheet contains tables and circuits for configuring the pins for a variety of cutoff frequencies and passband gains (The cutoff or -3dB frequency is a function of the f_0 frequency and Q value, refer to the Figure 3 filter equations in the LTC6601-1 data sheet).

Figure 2 shows an example of an LTC6601-1 configured as a 2nd order lowpass filter with a 10MHz -3dB frequency and a passband gain equal to 1 (0dB). The DC1251A-A/B demonstration circuit default configuration is the circuit of Figure 2.

The DC1251A has SMA connectors for the differential input and output, a jumper with shunts to set the LTC6601-X to high power (HP), low power (LP) or shutdown (SHDN) operation and turrets to connect an external VOCM. A DC1251A board operates with a single 2.7V to 5.5V power supply.

Design files for these circuit boards are available.

Call the LTC factory.

LT, LTC and LT are registered trademarks of Linear Technology Corporation.

Figure 1. An LTC6601-X Block Diagram.

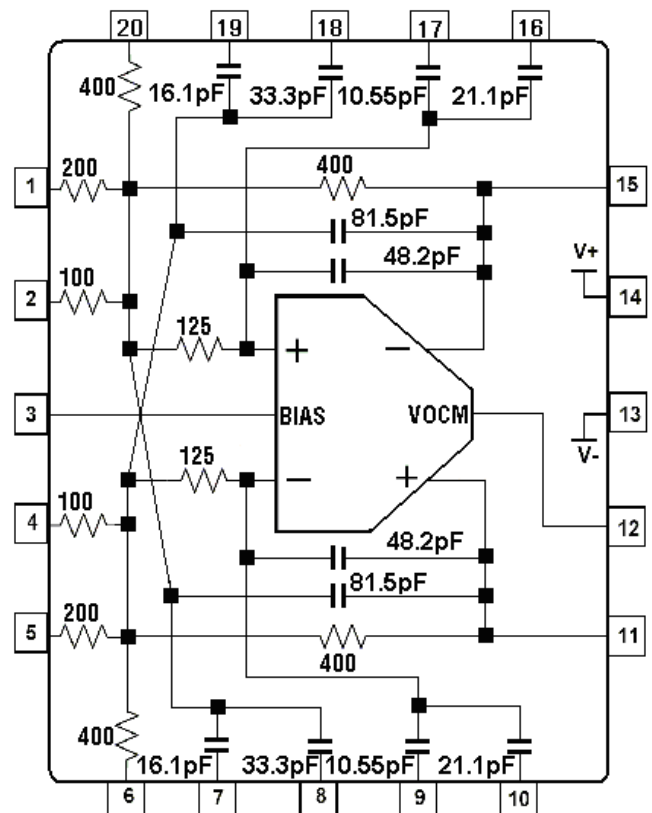
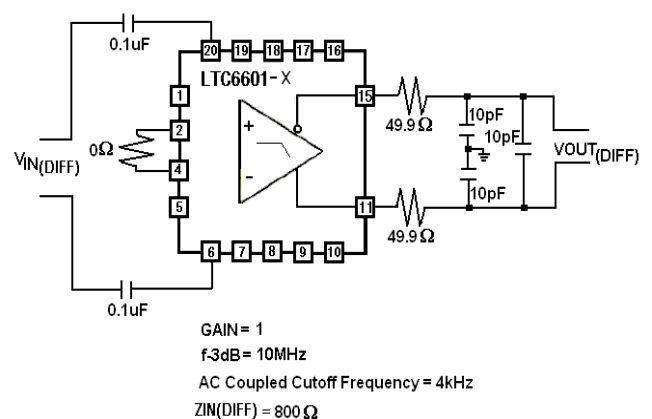

Figure 2. The LTC6601-X Circuit as configured in a DC1251A assembly.



DEMO CIRCUIT 1251 QUICK START GUIDE

5MHz TO 27MHz, PIN CONFIGURABLE, FULLY DIFFERENTIAL, 2ND ORDER LOWPASS FILTER

QUICK TEST SET-UP

Figure 3. A Quick Test Set-Up.

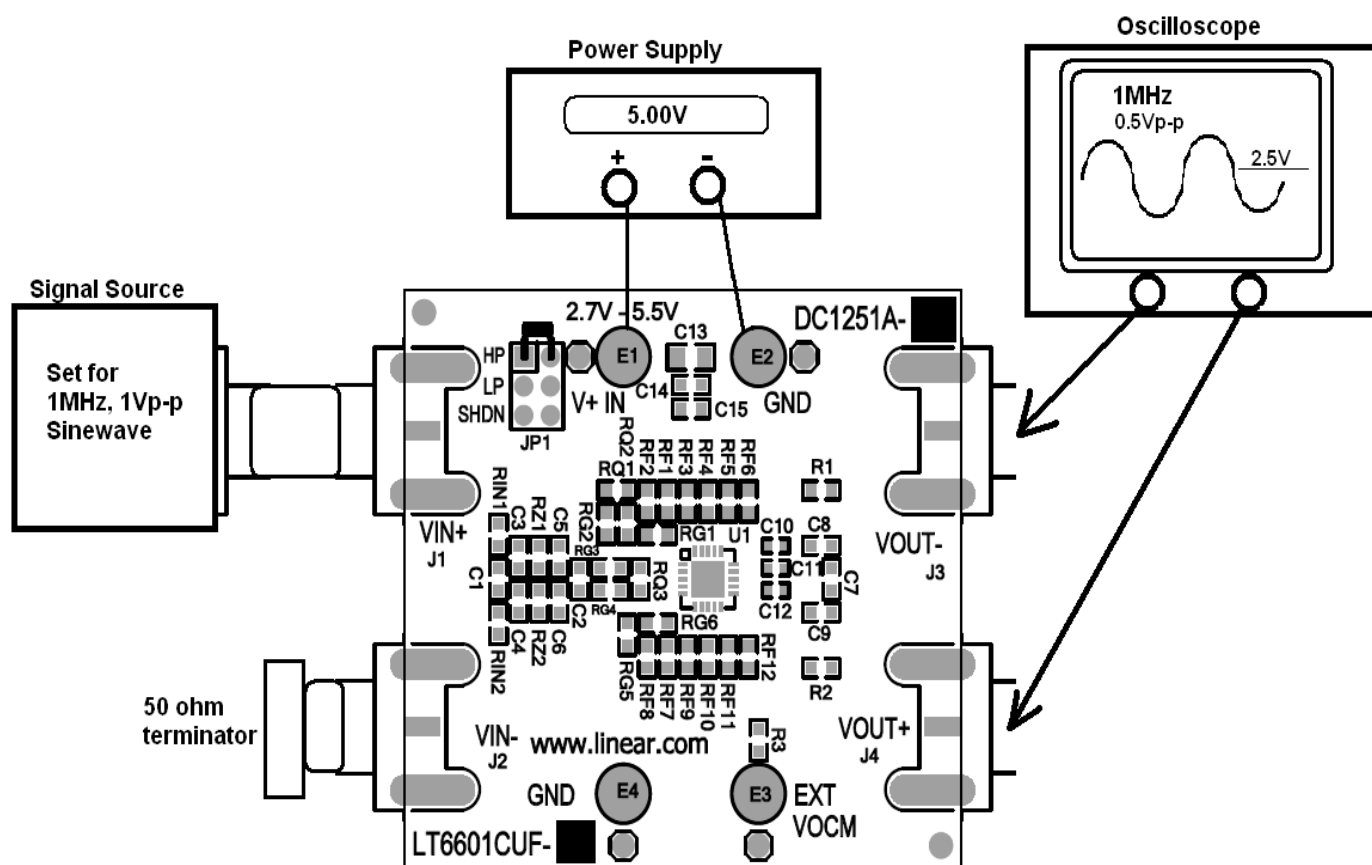

Quick Test Procedure

Test Equipment:

A Single Power Supply (3V – 5V).

A Sinewave Generator

An Oscilloscope (100MHz or greater).

1. Connect a DC1251 board as shown on Figure 1 (set the oscilloscope input impedance to $1M\Omega$).
2. Set the power supply to 3V.
3. Set the signal source output for a 1MHz, 1Vp-p sinewave.
4. Turn on the signal source and power supply.

5. Channel 1 and channel 2 on the oscilloscope should each show a 1MHz, 0.5Vp-p sine-wave.

Note 1: For accurate gain testing the DC1251 inputs must be ideally driven by a zero ohm source (for example, the outputs of a high speed differential amplifier). However, the 50 ohm impedance of the generator's output and terminator is in series with the LTC6601-X input resistors. A 50 ohm resistor in series with the input lowers the expected passband gain and changes the filter's Q value (refer to the Figure 3 GAIN and Q equations in the LTC6601-1 data sheet).

DEMO CIRCUIT 1251 QUICK START GUIDE

5MHZ TO 27MHZ, PIN CONFIGURABLE, FULLY DIFFERENTIAL, 2ND ORDER LOWPASS FILTER

CONFIGURING A DC1251 BOARD

The basic filter topology shown in Figure 4, can implement most LTC6601-X lowpass filter circuits. A DC1251A board has all the connections required for configuring the LTC6601-X basic filter topology. An example of a basic filter circuit and its DC1251A configuration is shown in Figure 6 and Figure 7 respectively.

The modified filter topology shown in Figure 4 provides for additional lowpass filter options. The use of the REXT resistor provides for setting precisely the filter's Q value without changing the fo frequency. In addition, the use of REXT provides for setting the filter's gain to greater than one without changing the Q value (refer to the Figure 13 Q equation in the LTC6601-1 data sheet).

The modified topology's C3 (the capacitor between the summing junction) implements lower Q values than the basic filter topology using only C1 and C2 (and lower Q values provide the option to implement lower -3dB frequencies).

A DC 1251A board has resistors pads for connecting the REXT of the modified topology. However the DC1251A layout does not have surface mount pads for connecting the 49.9 ohm resistor of the modified topology. An example of a modified filter circuit and its DC1251A configuration is shown in Figure 8 and Figure 9 respectively.

Note: The range of values for the resistor that connects the capacitors of the modified filter topology is 25–50 ohms.

Figure 4. The LTC6601-X basic filter topology.

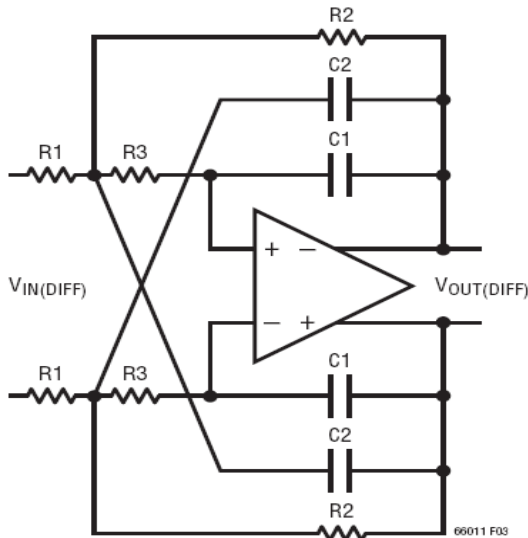
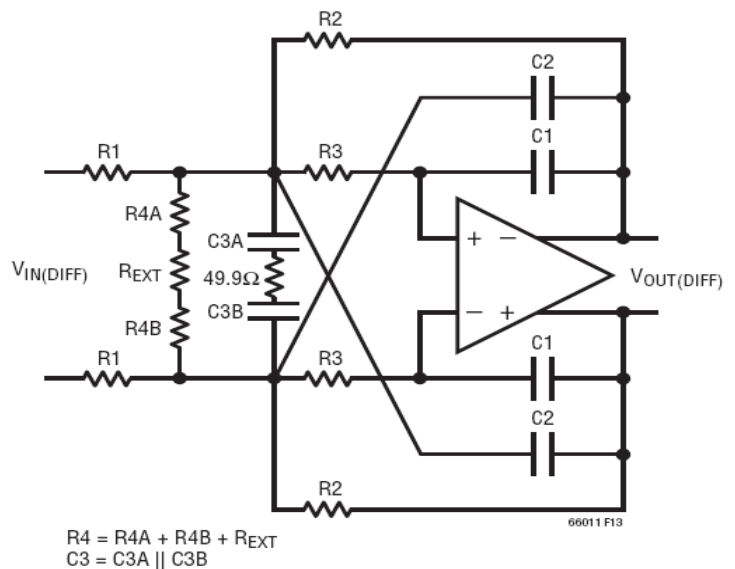

Figure 5. The LTC6601-X modified filter topology



DEMO CIRCUIT 1251 QUICK START GUIDE

5MHZ TO 27MHZ, PIN CONFIGURABLE, FULLY DIFFERENTIAL, 2ND ORDER LOWPASS FILTER

Figure 6. An LTC6601-1, Figure 4 circuit, configured as a 7MHz, lowpass filter with 12dB gain.

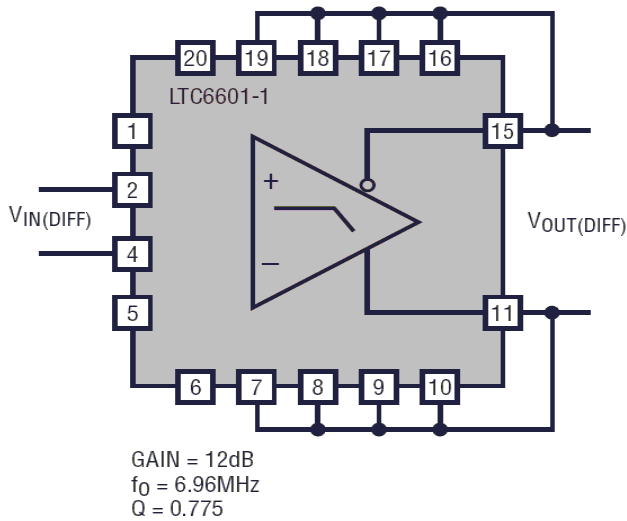
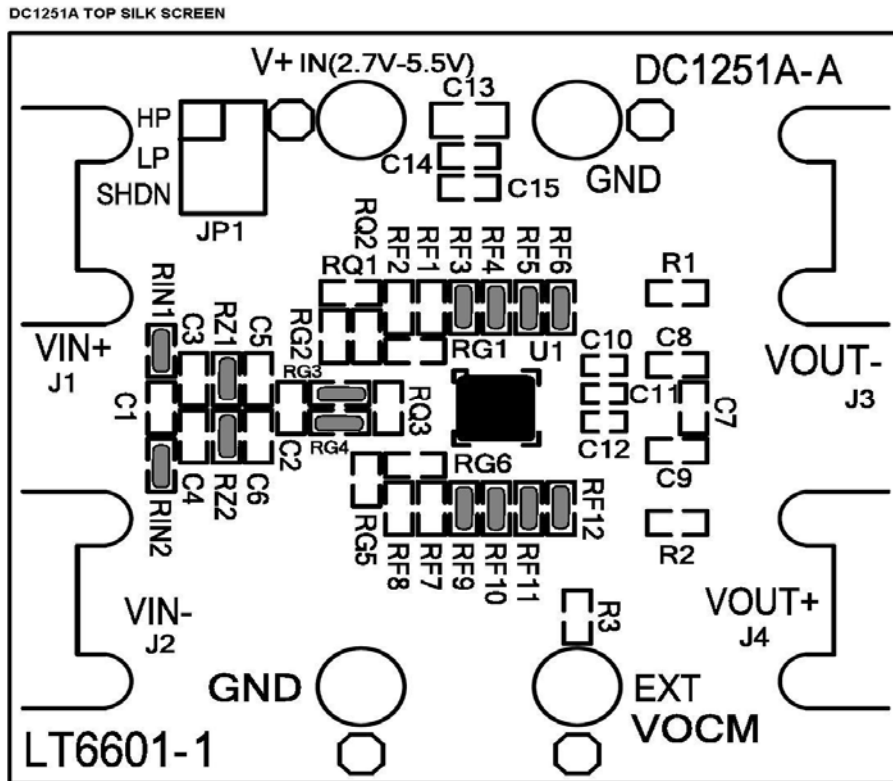

Figure 7. DC1251A configured as the Figure 6 circuit.

RIN1, RIN2, RG3, RG4, RF3-RF6, RF9-RF12 are zero ohm, 0603 resistors.
 For DC coupling, RZ1 and RZ2 are zero ohm resistors.
 For AC coupling, RZ1 and RZ1 are 0.1uF capacitors.



DEMO CIRCUIT 1251 QUICK START GUIDE

5MHz TO 27MHz, PIN CONFIGURABLE, FULLY DIFFERENTIAL, 2ND ORDER LOWPASS FILTER

Figure 8. An LTC6601-1, Figure 5 circuit, configured as a 5MHz, lowpass filter with 0dB gain.

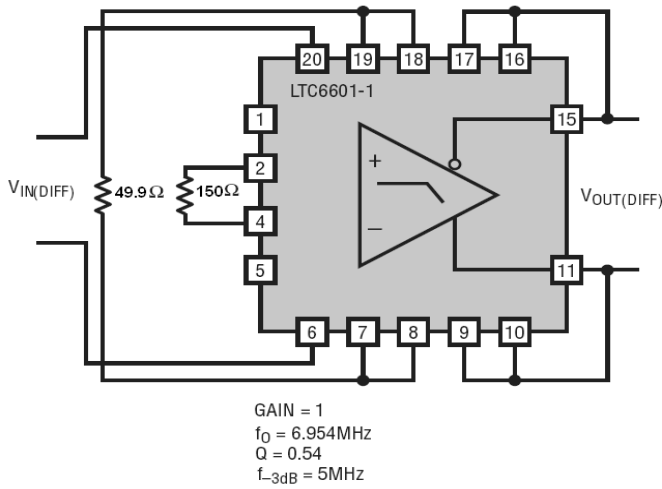
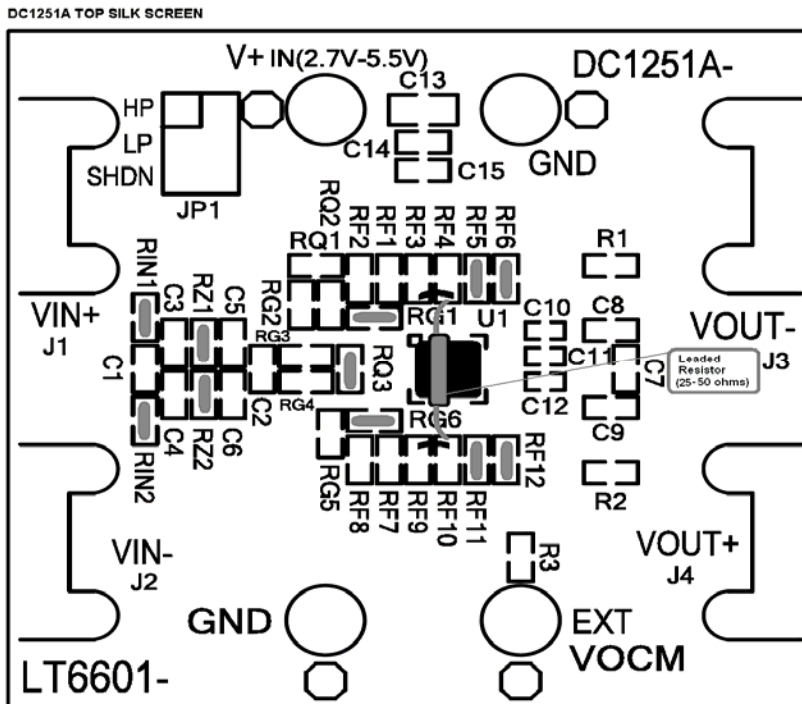

Figure 9. DC1251A configured as the Figure 8 circuit.

RIN1, RIN2, RG1, RG6, RF5-RF6, RF11 and RF12 are zero ohm, 0603 resistors.
 RQ3 is 150 ohms, 0603 resistor.
 For the 49.9 ohm resistor connection, short the RF3, RF4 and RF9, RF10 pads next to U1 and connect a 49.9 ohm resistor between the shorted pads.
 For DC coupling, RZ1 and RZ2 are zero ohm resistors.
 For AC coupling, RZ1 and RZ1 are 0.1uF capacitors.



DEMO CIRCUIT 1251 QUICK START GUIDE

5MHZ TO 27MHZ, PIN CONFIGURABLE, FULLY DIFFERENTIAL, 2ND ORDER LOWPASS FILTER

REVISION #		REVISION HISTORY		
SD	PC AD	FD	DATE	APPROVED
0	0	0		
2	2	2	02/12/08	Philip K
3	2	2	03/23/08	Philip K

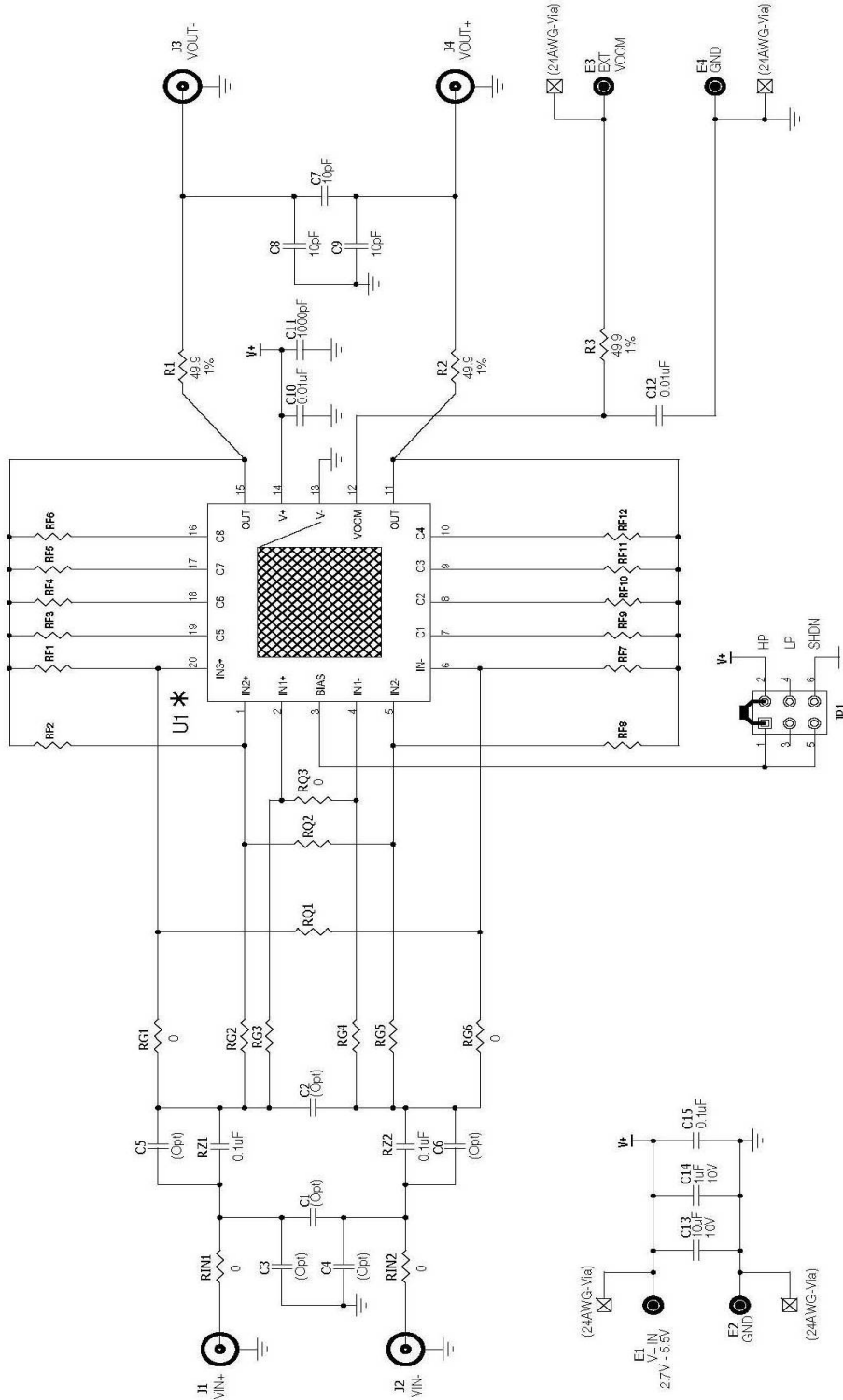

APPROVALS	
DRAWN: Rudy Bawdzisz	LINEAR TECHNOLOGY CORPORATION
ENGINEER: Philip K	1630 MCGARTHY BLVD
APPROVED:	MILPITAS, CA 95035
CHECKED:	(408)432-1900
	For Customer Use Only
	Title LTC6601CJF-1/LTC6601CJF-2
	Pin Programmable Amplifier and Filter (5MHz - 27MHz)
	Doc# Demo Circuit 1251A
Date: Tuesday, March 24, 2008	Sheet 1 of 1

This circuit is proprietary to Linear Technology and supplied for use with Linear Technology parts.

Customer Notice: Linear Technology has made a best effort to design a circuit that meets customers supplied specifications; however, it remains the customers responsibility to verify proper and reliable operation in the actual application. Component substitution and printed circuit board layout may significantly affect circuit performance or reliability. Contact Linear Applications Engineering for assistance.

BOARD ASSEMBLY

ASSY	U1
DC1251A-A	LTC6601CJF-1#TR
DC1251A-B	LTC6601CJF-2#TR

DEMO CIRCUIT 1251 QUICK START GUIDE

5MHZ TO 27MHZ, PIN CONFIGURABLE, FULLY DIFFERENTIAL, 2ND ORDER LOWPASS FILTER

DC1251A Parts List

Item	Qty	Reference	Part Description	Manufacturer / Part #
1	0	C1,C2,C3,C4,C5,C6(Opt)	Cap., 0603 TBD	
2	3	C7,C8,C9	Cap., NPO 10pF 25V 10%	AVX 06033A100KAT2A
3	2	C12,C10	Cap., X7R 0.01uF 16V 10%	AVX 0402YC103KAT2A
4	1	C11	Cap., X7R 1000pF 25V 10%	AVX 04023C102KAT2A
5	1	C13	Cap., X5R 10uF 10V 20%	Taiyo Yuden LMK212BJ106MG
6	1	C14	Cap., X5R 1uF 10V 20%	Taiyo Yuden LMK107BJ105MA-T
7	3	RZ1,RZ2,C15	Cap., X7R 0.1uF 25V 10%	AVX 06033C104KAT2A
8	4	E1,E2,E3,E4	Turret, Testpoint	Mill Max 2501-2-00-80-00-00-07-0
9	1	JP1	Headers, Dbl. Row 2 x 3 2mm Ctrs.	Samtec TMM-103-02-L-D
10	4	J1,J2,J3,J4	Conn., SMA 50-Ohm	EF Johnson 142-0701-851
11	0	RQ1,RF1,RQ2,RG2,RF2, (Opt) RG3,RF3,RG4,RF4,RG5, RF5,RF6,RF7,RF8,RF9, RF10,RF11,RF12	Res., 0603 TBD	
12	5	RIN1,RIN2,RG1,RG6,RQ3	Res/Jumper, Chip 0 1/16W 1 AMP	AAC CJ06-000M
13	3	R1,R2,R3	Res., Chip 49.9 0.1W 1%	VISHAY CRCW060349R9FKEA
14	0	TP1,TP2,TP3,TP4 (Opt)	Testpoint, Test pad	Component Corp. TP-107-02
15	1	XJP1	Shunt, 2mm Ctrs.	Samtec 2SN-BK-G

DC1251A-A

	1	U1	I.C., OpAmp	Linear Technology Corp. LTC6601CUF-1#TR
--	---	----	-------------	---

DC1251A-B

	1	U1	I.C., OpAmp	Linear Technology Corp. LTC6601CUF-2#TR
--	---	----	-------------	---

X-ON Electronics

Largest Supplier of Electrical and Electronic Components

Click to view similar products for [Active Filter Development Tools](#) category:

Click to view products by [Analog Devices](#) manufacturer:

Other Similar products are found below :

[MAXFILTERBRD+](#) [DC1418A-A](#) [DC962A-B](#) [DC962A-E](#) [DC962A-A](#) [DC338B-B](#) [131200-HMC900LP5E](#) [EKIT01-HMC1023LP5](#)
[EVAL01-HMC1044LP3E](#) [AFS1410-EVAL](#) [AFS2016-EVAL](#) [ADMV8432-EVALZ](#) [DC048A](#) [DC1251A-B](#) [DC1418A-B](#) [DC1418A-C](#)
[DC1418A-D](#) [DC962A-D](#) [EV1HMC881ALP5](#) [EV1HMC882ALP5](#) [EV1HMC891ALP5](#) [EVAL-FW-HPMFB2](#) [EVAL-FW-LPMFB2](#) [3-109-440](#) [3-111-353](#) [EVAL-FW-BPDF2](#) [EVAL-FW-HPMFB1](#) [EVAL-FW-HPSK2](#) [DC1251A-A](#) [3-115-037](#) [TPS7A3501EVM-547](#)