

# LTC4012-2

## MULTI CELL LI-ION BATTERY CHARGER BOARD

### DESCRIPTION

Demonstration circuit DC1256A is a single-battery stand-alone battery charger that can support any version of the LTC4012 family of parts. The LTC4012 family of charge controller IC's do not support charge termination for any specific battery chemistry. Any charger termination, if necessary, is accomplished outside the LTC4012 with the most common method using a microcontroller. The DC1256A is shipped with the LTC4012-2 installed, which is optimized for Li-ion charge applications using a 4.2V/Cell float voltage. The charger output voltage is programmed by jumpers to support 1, 2, 3 and 4 series stack Li-ion batteries. The input voltage is can be between 6V and 20V with the maximum voltage of the Demoboard design limited by the input capacitor voltage ratings. To reach full charge, the minimum input voltage must be greater than the float voltage setting. For optimal operation,  $V_{in}$  needs to be about 1.5V higher than the float voltage for fastest charge times. No matter what, the input voltage must be 6V minimum for the IC to work at all. The maximum charge current of the design is 3A. The Demoboard is shipped configured for 12.6V Li-ion batteries using a 15V to 20V input. By default, the charger will turn on with input power. However, if JP7 is set to the THM position, the power state will be determined by the physical presence of a battery on the battery connector. As designed, it is compatible with Smart Batteries where a dedicated pin is used to indicate battery presence. A standard battery can and should use the same idea. Status LEDs are provided for CHG, ACP, C/10, and ICL.

DC1256A also optionally includes an efficient battery discharge path via Q11. This circuit automatically turns on when  $V_{in}$  goes below the  $V_{bat}$ . Since Q1-2 is off when the charger not charging or  $V_{in}$  goes away, it is not wise to allow any battery current to flow though Q1-2 via its parasitic diode. Excessive battery discharge current will easily destroy Q1.

Although this charger is not a Smart Battery charger, the battery connector follows the industry standard. Optional use of a Smart Battery will permit data-logging with the OPTIONAL DC1223 Demoboard via J2. To be clear, you do NOT need a Smart Battery or the DC1223 to use the DC1256A Demoboard. DC1223 is an SMBus-to-USB port adapter and comes with associated software to monitor a Smart Battery for demonstration or characterization purposes only. Contact your LT representative for ordering a DC1223.

This Demoboard is capable of supporting the LTC4012, and LTC4012-1 with a simple IC swap-out. The LTC4012-1 sets the per-cell voltage to 4.1V/Cell for Li-ion where as the 4012 is a fully adjustable version for all other battery chemistries such as SLA or the now popular Lithium Iron Phosphate (LiFePo). See schematic.

**Design files for this circuit board are available. Call the LTC factory.**

**Table 1. As Shipped Performance Summary**

PARAMETER	CONDITIONS / NOTES	VALUE
Maximum Input Voltage	Limited by Input Capacitor Volt Ratings.	20V
Charge Float Voltage	JP1 = 1-2 & JP2 = 2-3	12.6V +/- 0.5%
Minimum Input Voltage	Using a 12.6V Li-ion battery.	15V recommended
Input Current Limit	JP4 at 4A setting.	4 Amps +/- 3.2%
Maximum Charge Current	$V_{in} \geq V_{bat} + 1.5V$	3A +/- 4.2%

**Table 2. Jumper Description**

JUMPER	FUNCTION	RANGE/SETTING (DEFAULT)
JP1 & JP2	SETUP: Charge Float Voltage.	4.2V, 8.4V, (12.6V) & 16.8V
JP3	LED PWR. Used for eliminate status LED current drain on Vcc.	(ON) - OFF
JP4	INPUT: Selects the Input Current Limit (ICL) Trip point.	(4A) - 2A
JP5	VCC SELECT: Selects what power source for Vcc power. Internally via U2 or Externally via EXT VCC pin.	(INT) - EXT
JP6	INTERNAL VCC: Enables or Disable Vout as the input power source for U2 and optional DC410/DC1223 adapter boards.	(ON) - OFF
JP7	SHUTDOWN: Controls how LTC4012 will run when input power is provided. THM = Extra pin on battery connector is used as Battery Detection. See text.	OFF - THM - (ON)

**Table 3. LED Status Indications**

LED	FUNCTION (ONLY VALID WHEN ACP IS ON)	VALUE ON	VALUE OFF
C/10	Charge current has fallen to 1/10 of full scale. (Top off Charge mode)	Icharge < 300mA	Icharge > 300mA
CHG	Charge current is above C/10. (Bulk Charge mode.)	Icharge > 300mA	Icharge < 300mA
ICL	Shows that Input Current Limit (ICL) is active.	Iin > ICL	Iin < ICL
ACP	Indicates Vin is sufficient to start charging the battery. Does not guarantee battery will reach full charge unless Vin > Vfloat.	ON: Vin > Vbat.	OFF: Vin < Vbat

## QUICK START PROCEDURE

1. Connect the input power source to VIN terminals J1 or VIN and GND using a power supply capable of handling 4.5A of current within a 13.5 to 20V range. The input supply voltage MUST be greater than the full voltage value of the battery to allow a full charge to take place.
2. Connect the load to VOUT and GND terminals.
3. Configure the jumpers for your specific battery.
4. Plug in the battery. Industry standard 5 Pin AMP Smart Battery connector is provided as well as generic soldering Test Points for hardwire connections.
5. Turn on the input power supply.
6. Optionally use the provided DC1223A demonstration software to configure and communicate with the DC1256A.

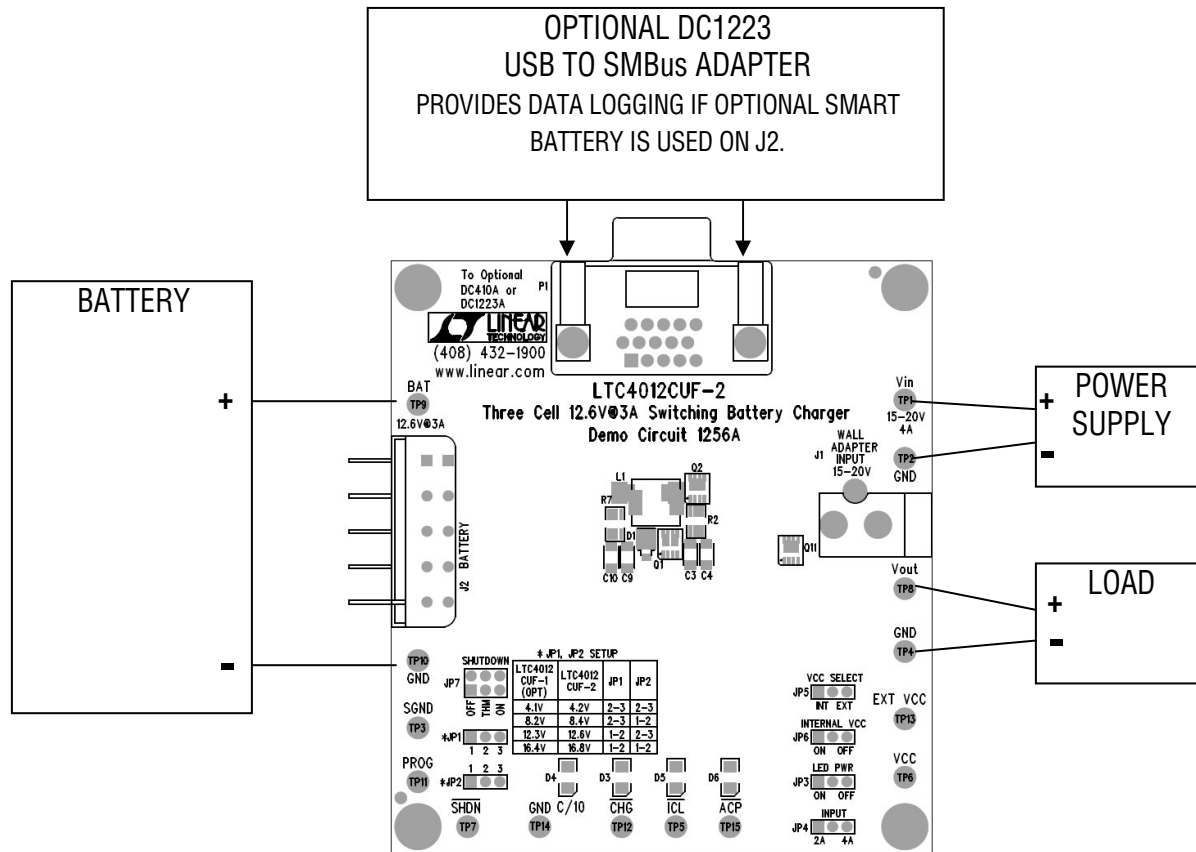

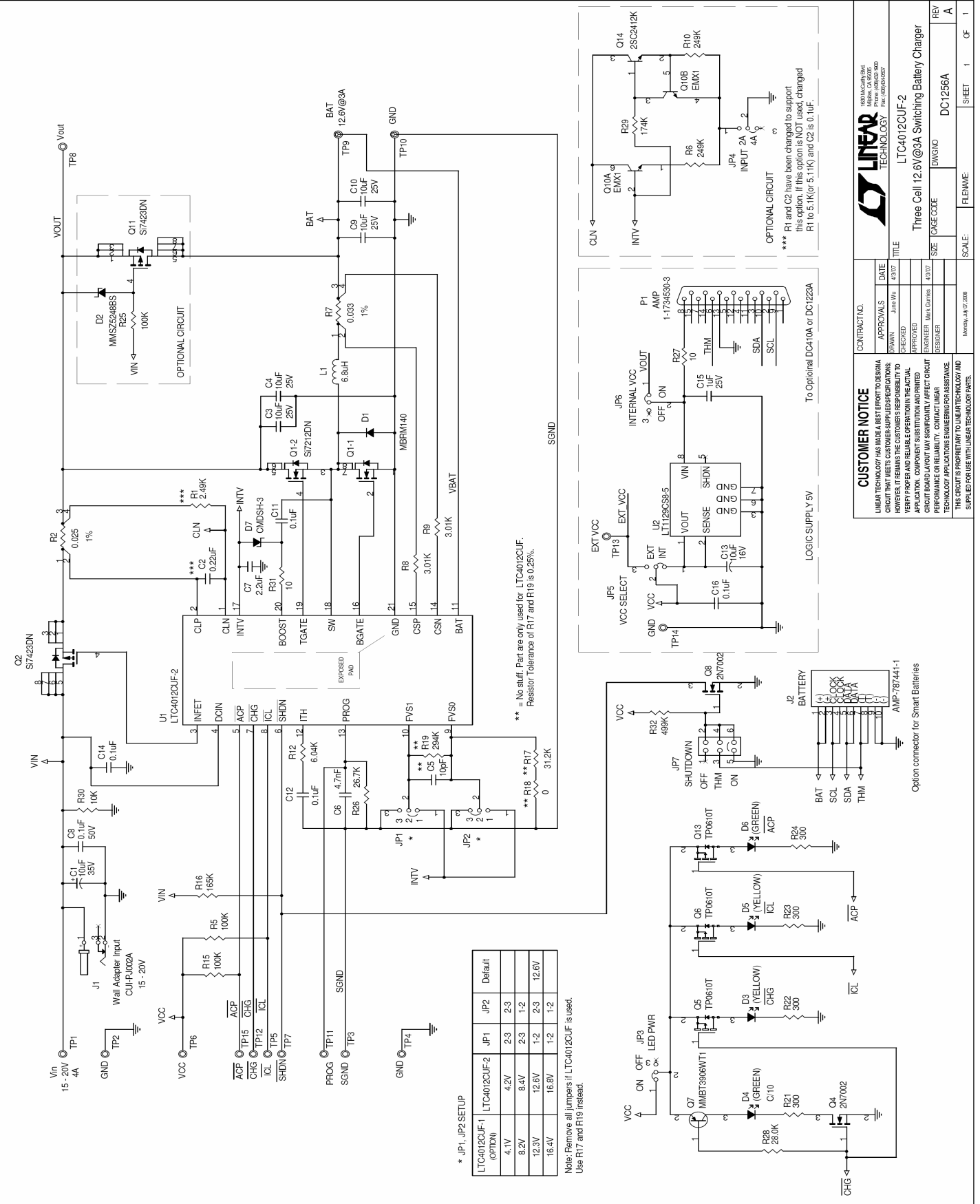

\* JP1, JP2 SETUP

LTC4012CUF-1 (OPTN)	JP1	JP2	Default
4.1V	2-3	2-3	
8.2V	2-3	1-2	
12.3V	1-2	2-3	12.6V
16.4V	1-2	1-2	

Note: Remove all jumpers if LTC4012CUF is used. Use R17 and R19 instead.

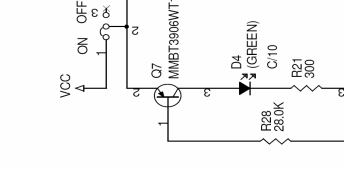
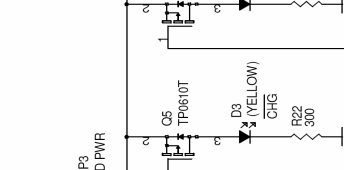
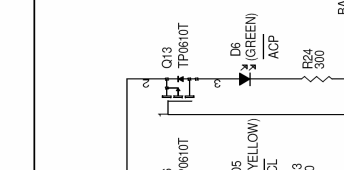
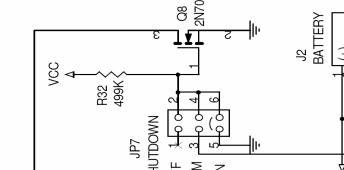
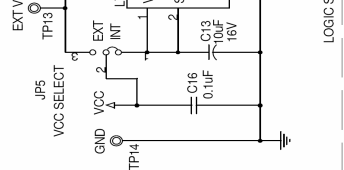
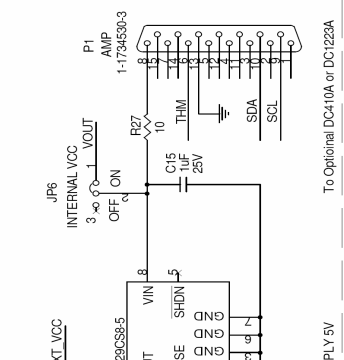
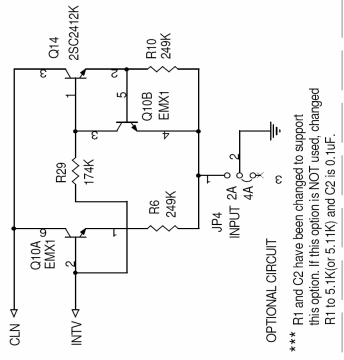

**CUSTOMER NOTICE**  
 LINEAR TECHNOLOGY HAS MADE A BEST EFFORT TO DESIGN A CIRCUIT THAT MEETS CUSTOMER-SUPPLIED PERFORMANCE REQUIREMENTS. HOWEVER, IT REMAINS THE CUSTOMER'S RESPONSIBILITY TO VERIFY PROPER AND RELIABLE OPERATION IN THE ACTUAL APPLICATION. CUSTOMER'S OWNERSHIP OF THE ACTUAL CIRCUIT BOARD (PRINT) MAY SIGNIFICANTLY AFFECT CIRCUIT PERFORMANCE OR RELIABILITY. CONTACT LINEAR TECHNOLOGY APPLICATIONS ENGINEERING FOR ASSISTANCE. THIS CIRCUIT IS PROPRIETARY TO LINEAR TECHNOLOGY AND SUPPLIED FOR USE WITH LINEAR TECHNOLOGY PARTS.

CONTRACT NO. \_\_\_\_\_  
 APPROVALS \_\_\_\_\_ DATE \_\_\_\_\_  
 DRAWN \_\_\_\_\_ DATE \_\_\_\_\_  
 CHECKED \_\_\_\_\_  
 APPROVED \_\_\_\_\_  
 ENGINEER \_\_\_\_\_  
 DESIGNER \_\_\_\_\_

LINEAR TECHNOLOGY  
 100 Webster Street  
 Milpitas, CA 95035  
 Phone: (408) 255-0000  
 Fax: (408) 255-0001

LTC4012CUF-2  
 Three Cell 12.6V@3A Switching Battery Charger

REV \_\_\_\_\_  
 DWGNO \_\_\_\_\_  
 CAGE CODE \_\_\_\_\_  
 DC1256A

SCALE: \_\_\_\_\_ SHEET 1 OF 1

\*\*\* R1 and C2 have been changed to support this option. If this option is NOT used, changed R1 to 5.1K (or 5.1K) and C2 is 0.1uF.

To Optional DC410A or DC1223A

LOGIC SUPPLY 5V

Option connector for Smart Batteries

AMP-787441-1

## X-ON Electronics

Largest Supplier of Electrical and Electronic Components

*Click to view similar products for [Power Management IC Development Tools](#) category:*

*Click to view products by [Analog Devices](#) manufacturer:*

Other Similar products are found below :

[EVAL-ADM1168LQEBZ](#) [EVB-EP5348UI](#) [MIC23451-AAAYFL EV](#) [MIC5281YMME EV](#) [DA9063-EVAL](#) [ADP122-3.3-EVALZ](#) [ADP130-0.8-EVALZ](#) [ADP130-1.2-EVALZ](#) [ADP130-1.5-EVALZ](#) [ADP130-1.8-EVALZ](#) [ADP1714-3.3-EVALZ](#) [ADP1716-2.5-EVALZ](#) [ADP1740-1.5-EVALZ](#) [ADP1752-1.5-EVALZ](#) [ADP1828LC-EVALZ](#) [ADP1870-0.3-EVALZ](#) [ADP1871-0.6-EVALZ](#) [ADP1873-0.6-EVALZ](#) [ADP1874-0.3-EVALZ](#) [ADP1882-1.0-EVALZ](#) [ADP199CB-EVALZ](#) [ADP2102-1.25-EVALZ](#) [ADP2102-1.875EVALZ](#) [ADP2102-1.8-EVALZ](#) [ADP2102-2-EVALZ](#) [ADP2102-3-EVALZ](#) [ADP2102-4-EVALZ](#) [ADP2106-1.8-EVALZ](#) [ADP2147CB-110EVALZ](#) [AS3606-DB](#) [BQ24010EVM](#) [BQ24075TEVM](#) [BQ24155EVM](#) [BQ24157EVM-697](#) [BQ24160EVM-742](#) [BQ24296MEVM-655](#) [BQ25010EVM](#) [BQ3055EVM](#) [NCV891330PD50GEVB](#) [ISLUSBI2CKIT1Z](#) [LM2744EVAL](#) [LM2854EVAL](#) [LM3658SD-AEV/NOPB](#) [LM3658SDEV/NOPB](#) [LM3691TL-1.8EV/NOPB](#) [LM4510SDEV/NOPB](#) [LM5033SD-EVAL](#) [LP38512TS-1.8EV](#) [EVAL-ADM1186-1MBZ](#) [EVAL-ADM1186-2MBZ](#)