

LTC6410-6 Differential IF Amplifier Four-Port Test Board

DESCRIPTION

Demonstration circuit 1264 features the LTC6410-6 low noise, low distortion differential Intermediate Frequency (IF) Amplifier. This second evaluation board is meant for four-port network analysis or in-circuit evaluation with a minimal number of board parasitic to achieve the full performance of the LTC6410-6. **For a general-purpose evaluation board for the LTC6410-6, obtain Demo Circuit 1103.**

The LTC6410-6 is a high-speed differential amplifier with superior distortion and noise performance, perfect for demanding communications transceivers, cellular base-

stations, and other high-speed signal chain applications. The LTC6410-6 features a fully differential input and output and is capable of directly driving a 50Ω load. One standout feature of the LTC6410-6 is the ability to independently adjust the input impedance with two resistors at the inputs. This allows the user to easily enhance the noise figure and power gain of the system for optimal performance.

Design files for this circuit board are available. Call the LTC factory.

 , LTC and LT are registered trademarks of Linear Technology Corporation.

QUICK START PROCEDURE

Table 1 shows the function of each SMA connector on the board. Refer to Figure 1 and follow the procedure below:

1. Connect the power supply to the VCC and GND turrets on the board. The LTC6410-6 accepts supply voltages from 2.8-5.25V. The power supply must be capable of supplying at least 150mA. The GND turret is directly connected to the board ground for single-supply operation.
2. Apply an input signal to J2 and J1. The input is fully differential and impedance-matched to 50Ω by default; no external termination is necessary. Resistors R1 and R2 can be used to change the input impedance of the LTC6410.

3. Observe the output via J4 and J3. The output is capable of driving a 50Ω load, such as the input of a network or spectrum analyzer.

Table 1: DC1264 Connector Descriptions

CONNECTOR	FUNCTION
J1 (-IN)	Differential Input. AC-Coupled by capacitor C1.
J2 (+IN)	Differential Input. AC-Coupled by capacitor C2.
TP1 (VOCM)	Self-Bias Voltage Adjust. Corresponds to VBIAS pin of LTC6410. By default, 1.45V is supplied to this pin by two resistors (VCC=3V). Override this voltage with any low-impedance DC voltage source.
J3 (-OUT)	Differential Output. AC-Coupled by capacitor C3.
J4 (+OUT)	Differential Output. AC-Coupled by capacitor C3.

DEMO CIRCUIT DC1264 QUICK START GUIDE

LOW NOISE, LOW DISTORTION DIFFERENTIAL IF AMPLIFIER

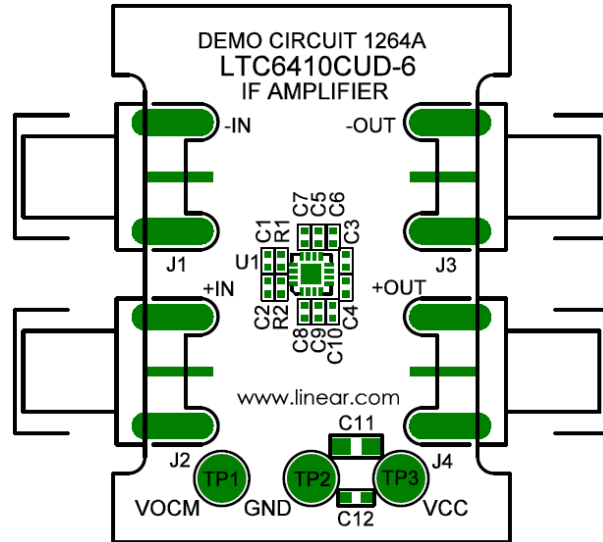

Figure 1. DC1264 Four-Port Evaluation Board

ADDITIONAL INFORMATION

Although the DC1264 demo board is designed for use with four-port network analyzers, it can also be used for in-circuit evaluation of the LTC6410-6. This and other important board information are included in this section.

SMA CONNECTOR SPACING

The input and output SMA connectors are spaced 0.6” (15.24mm) apart, suitable for direct connection to the DC1119 demo board for Linear Technology’s LT5527, LT5557, and LT5559 high linearity downconverting mixers.

ADJUSTING THE INPUT IMPEDANCE

The input impedance of the LTC6410 can be adjusted in the range of 58Ω-2000Ω by replacing R1 and R2 with equal-value non-zero resistors. The correct resistor value for the desired *differential* input impedance is:

$$R_1, R_2 = \frac{(3810 \cdot Z_{DIFF}) - 220000}{2000 - Z_{DIFF}}$$

Adjusting the input impedance too high may affect the performance of the part. See the LTC6410 datasheet.

DC-COUPLING THE INPUTS/OUTPUTS

It is possible to DC-couple the LTC6410 in the signal chain. Capacitors C1-C2 and C3-C4 should be replaced with 0Ω resistors. The inputs must be biased to within the common-mode range of the LTC6410.

The common-mode voltage at the LTC6410 inputs will propagate through to the outputs. The resistive load to ground at each output should be considered so that excessive current is not drawn from the outputs when DC-coupled. A differential R_{LOAD} should be used instead to avoid large quiescent load currents.

CHANGING THE BIAS VOLTAGE

Turret TP1 controls the self-bias voltage of DC1264. This function can be used to bias the next stage for optimum system performance. By default, internal resistors supply 1.45V to the V_{BIAS} pin (with V_{CC}=3.0V). This voltage can be over-ridden with an external voltage source at TP4 and/or by DC-coupling the inputs of the LTC6410.

DEMO CIRCUIT DC1264 QUICK START GUIDE

LOW NOISE, LOW DISTORTION DIFFERENTIAL IF AMPLIFIER

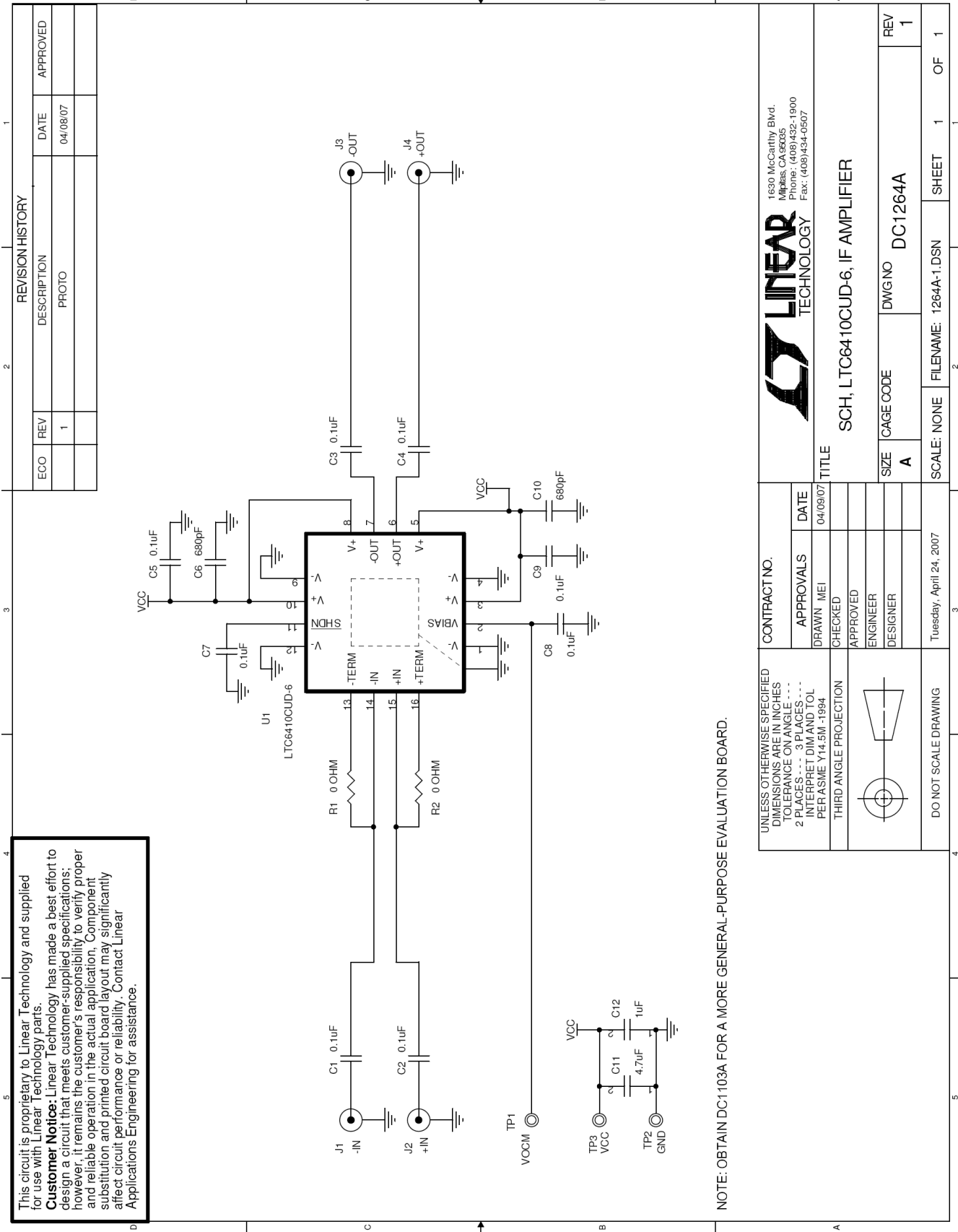

NOTE: OBTAIN DC1103A FOR A MORE GENERAL-PURPOSE EVALUATION BOARD.

This circuit is proprietary to Linear Technology and supplied for use with Linear Technology parts.
Customer Notice: Linear Technology has made a best effort to design a circuit that meets customer-supplied specifications; however, it remains the customer's responsibility to verify proper and reliable operation in the actual application. Component substitution and printed circuit board layout may significantly affect circuit performance or reliability. Contact Linear Applications Engineering for assistance.

X-ON Electronics

Largest Supplier of Electrical and Electronic Components

Click to view similar products for [Amplifier IC Development Tools](#) category:

Click to view products by [Analog Devices](#) manufacturer:

Other Similar products are found below :

[EVAL-ADCMP566BCPZ](#) [EVAL-ADCMP606BKSZ](#) [AD8013AR-14-EBZ](#) [AD8033AKS-EBZ](#) [AD8044AR-EBZ](#) [AD8225-EVALZ](#)
[ADA4859-3ACP-EBZ](#) [ADA4862-3YR-EBZ](#) [DEM-OPA-SO-2B](#) [AD744JR-EBZ](#) [AD8023AR-EBZ](#) [AD8030ARJ-EBZ](#) [AD8040ARU-EBZ](#)
[AD8073JR-EBZ](#) [AD813AR-14-EBZ](#) [AD848JR-EBZ](#) [ADA4858-3ACP-EBZ](#) [ADA4922-1ACP-EBZ](#) [551600075-001/NOPB](#) [DEM-OPA-SO-](#)
[2E](#) [THS7374EVM](#) [EVAL-ADCMP553BRMZ](#) [EVAL-ADCMP608BKSZ](#) [MIOP 42109](#) [EVAL-ADCMP609BRMZ](#) [MAX9928EVKIT+](#)
[MAX9636EVKIT+](#) [MAX9611EVKIT](#) [MAX9937EVKIT+](#) [MAX9934TEVKIT+](#) [MAX44290EVKIT#](#) [MAX2644EVKIT](#) [MAX2634EVKIT](#)
[MAX4073EVKIT+](#) [DEM-OPA-SO-2C](#) [MAX2643EVKIT](#) [ISL28158EVAL1Z](#) [MAX40003EVKIT#](#) [MAX2473EVKIT](#) [MAX2472EVKIT](#)
[MAX4223EVKIT](#) [MAX9700BEVKIT](#) [MADL-011014-001SMB](#) [DC1685A](#) [DEM-OPA-SO-2D](#) [MAX2670EVKIT#](#) [DEM-OPA-SO-1E](#)
[AD8137YCP-EBZ](#) [EVAL-ADA4523-1ARMZ](#) [MAX44242EVKIT#](#)