

DESCRIPTION

Demonstration circuit 1283 is an ultra-low dropout voltage supply using the LTC3025-1 linear regulator, which comes in a small 2mm x 2mm 6-Pin DFN package. The DC1283A has an input voltage range from 0.9V to 5.5V, an output voltage range between 0.4V and 2.6V, and is capable of delivering 500 mA max of output current. The 0.4V reference of the LTC3025-1 allows the DC1283A to supply power to very low voltage applications. The DC1283A is also an excellent choice for post

regulation of step-down switching regulators, combining to create a high efficiency low-noise supply. The DC1283 comes installed with small ceramic capacitors, showing the LTC3025-1 ability to maintain stability with ceramic output capacitors.

Design files for this circuit board are available. Call the LTC factory.

Table 1.

Performance Summary ($T_A = 25^\circ\text{C}$)

PARAMETER	CONDITIONS	VALUE
Input Voltage Range		0.9V to 5.5V
Bias Voltage Range	$V_{\text{BIAS}} \geq V_{\text{OUT}} + 1.5\text{V}$	2.5V to 5.5V
Output Voltage Regulation	$V_{\text{IN}} = 2.25\text{V to } 5.5\text{V}$, $I_{\text{OUT}} = 0\text{A to } 500\text{ mA}$, $V_{\text{BIAS}} = 5\text{V}$	0.8V \pm 2%(1.152V to 1.248V)
		1.2V \pm 2%(1.152V to 1.248V)
		1.5V \pm 2%(1.44V to 1.56V)
		1.8V \pm 2%(1.728V to 1.872V)
Typical Dropout Voltage	$V_{\text{IN}} = 1.5\text{V}$, $V_{\text{BIAS}} = 2.8\text{V}$, $I_{\text{OUT}} = 500\text{mA}$	75mV
Typical Output Voltage Ripple & Noise		< 10mV _{p-p}

QUICK START PROCEDURE

The DC1283 demonstration board is easy to set up to evaluate the performance of the LTC3025-1. For proper measurement equipment configuration, set up the circuit according to the diagram in Figure 2. Before proceeding to test, insert the Vout Enable jumper into the OFF (upper) position, connecting the RUN pin to ground (GND), which shuts down the circuit.

When measuring the input or output ripple or noise voltage, care must be taken to avoid a long ground lead on the oscilloscope probe. Measure the voltages by touching the probe tip

directly across the Vin or Vout and GND terminals. See Figure 1 for proper scope probe technique. The DC1283 is easy to set up to evaluate the performance of the LTC3025-1. For a proper measurement equipment configuration, set up the circuit according to the diagram in Figure 2.

Please follow the procedure outlined below for proper operation.

QUICK START GUIDE FOR DEMONSTRATION CIRCUIT 1283

500mA VERY LOW DROPOUT LINEAR REGULATOR

1. Before proceeding to test, insert the Vout Enable jumper into the OFF position, and insert a shunt into jumper of the 1.2V output voltage option.
2. Apply 1.4V to Vin (100 mV above Vout), and 5V to Vbias.

Caution: The bias voltage must be 1.5V, or greater, above the output voltage, and it must be 2.5V, or greater, for the circuit to regulate.

Insert Vout Enable jumper into the ON position. Measure Vout; it should be 1.2V +/- 2% (1.176V to 1.224V).

3. Vary the input voltage from 1.4V to 5.5V and the load current from no load to 500 mA. Vout should measure 1.2V +/- 2% (1.176V to 1.224V).
4. Insert the Vout Enable jumper into the OFF position and move the Vout shunt from the 1.2V option into any of the remaining output voltage options: 0.8V, 1.5V, or 1.8V.

Re-insert the Vout Enable jumper into the ON position. Just as in the 1.2V Vout test, the output voltage should read Vout +/- 2% tolerance under static line and load conditions, and +/- 2% tolerance under dynamic line and load conditions.

5. When finished evaluating, insert the Vout Enable jumper into the OFF position.

Note - If the power for the demo board is carried in long leads, the input voltage at the part could "ring", due to the inductance in the long leads. This ringing could affect the operation of the circuit or even exceed the maximum voltage rating of the IC. To eliminate the ringing, a small tantalum capacitor (for instance, an AVX part # TAJW226M010R) was inserted on the pads between the input power and return terminals on the bottom of the demo board. The (greater) ESR of the tantalum will dampen the (possible) ringing voltage due to the use of long input leads. On a normal, typical PCB, with short traces, the capacitor is not needed.

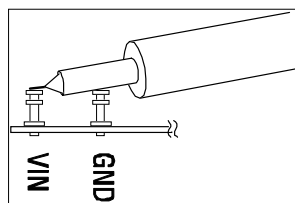

Figure 1. Measuring Input or Output Ripple

QUICK START GUIDE FOR DEMONSTRATION CIRCUIT 1283

500mA VERY LOW DROPOUT LINEAR REGULATOR

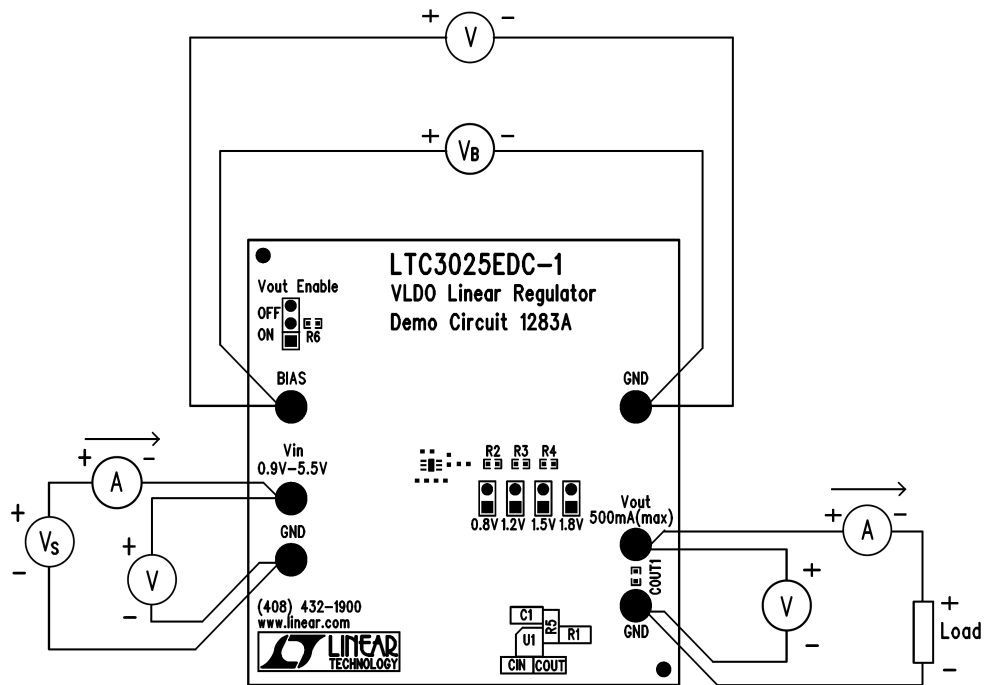

Figure 2. Proper Measurement Equipment Setup

QUICK START GUIDE FOR DEMONSTRATION CIRCUIT 1283

500mA VERY LOW DROPOUT LINEAR REGULATOR

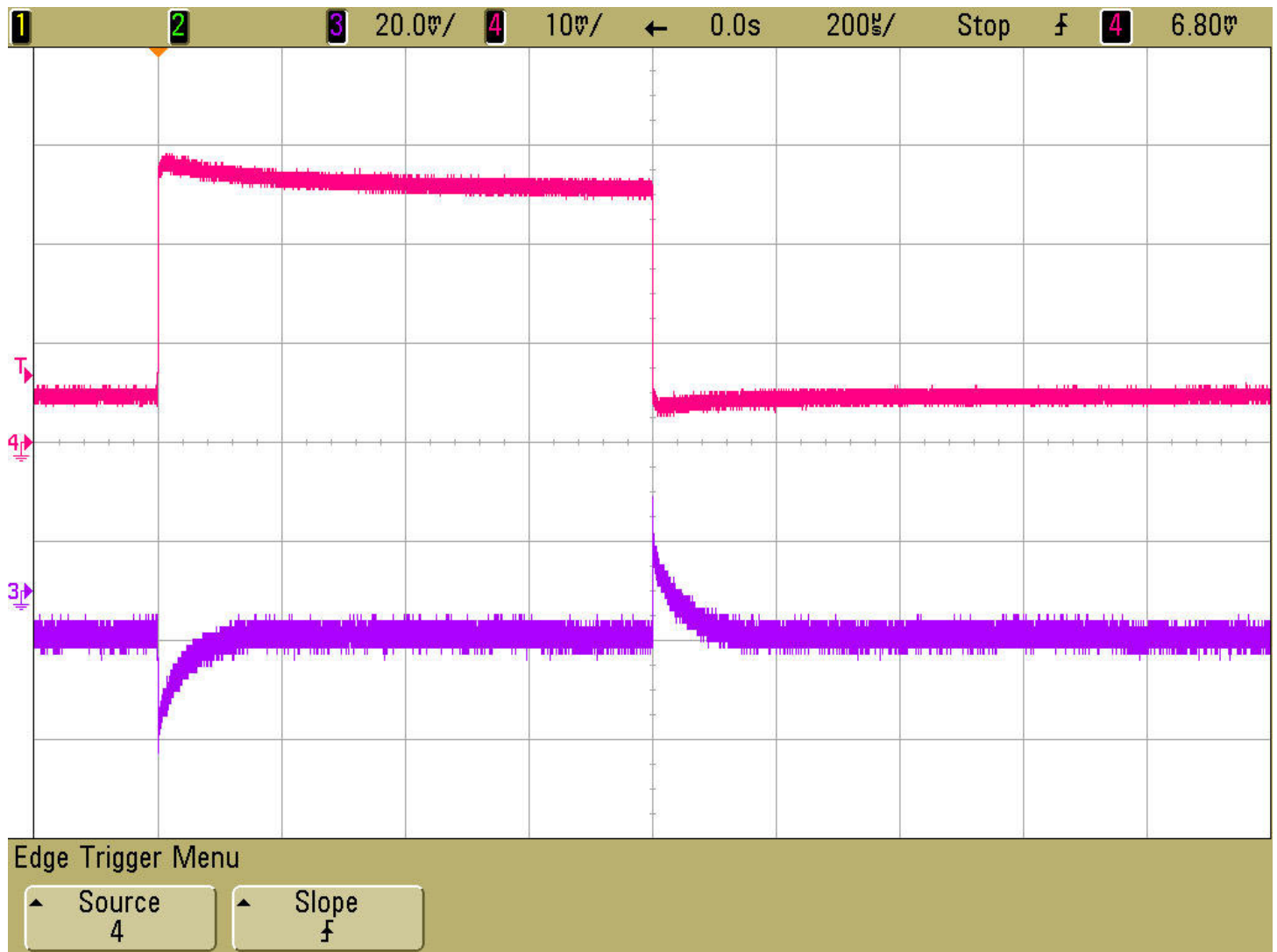

Figure 3. Load Step Response

$V_{IN} = 2.5V$, $V_{BIAS} = 5V$, $V_{OUT} = 1.5V$, 400 mA Load Step (100 mA \leftrightarrow 500 mA)

Trace 3: Output Current (100 mA/div)
Trace 4: Output Voltage (20mV/div AC)

X-ON Electronics

Largest Supplier of Electrical and Electronic Components

Click to view similar products for [Power Management IC Development Tools](#) category:

Click to view products by [Analog Devices](#) manufacturer:

Other Similar products are found below :

[EVAL-ADM1168LQEBZ](#) [EVB-EP5348UI](#) [MIC23451-AAAYFL EV](#) [MIC5281YMME EV](#) [DA9063-EVAL](#) [ADP122-3.3-EVALZ](#) [ADP130-0.8-EVALZ](#) [ADP130-1.2-EVALZ](#) [ADP130-1.5-EVALZ](#) [ADP130-1.8-EVALZ](#) [ADP1714-3.3-EVALZ](#) [ADP1716-2.5-EVALZ](#) [ADP1740-1.5-EVALZ](#) [ADP1752-1.5-EVALZ](#) [ADP1828LC-EVALZ](#) [ADP1870-0.3-EVALZ](#) [ADP1871-0.6-EVALZ](#) [ADP1873-0.6-EVALZ](#) [ADP1874-0.3-EVALZ](#) [ADP1882-1.0-EVALZ](#) [ADP199CB-EVALZ](#) [ADP2102-1.25-EVALZ](#) [ADP2102-1.875EVALZ](#) [ADP2102-1.8-EVALZ](#) [ADP2102-2-EVALZ](#) [ADP2102-3-EVALZ](#) [ADP2102-4-EVALZ](#) [ADP2106-1.8-EVALZ](#) [ADP2147CB-110EVALZ](#) [AS3606-DB](#) [BQ24010EVM](#) [BQ24075TEVM](#) [BQ24155EVM](#) [BQ24157EVM-697](#) [BQ24160EVM-742](#) [BQ24296MEVM-655](#) [BQ25010EVM](#) [BQ3055EVM](#) [NCV891330PD50GEVB](#) [ISLUSBI2CKIT1Z](#) [LM2744EVAL](#) [LM2854EVAL](#) [LM3658SD-AEV/NOPB](#) [LM3658SDEV/NOPB](#) [LM3691TL-1.8EV/NOPB](#) [LM4510SDEV/NOPB](#) [LM5033SD-EVAL](#) [LP38512TS-1.8EV](#) [EVAL-ADM1186-1MBZ](#) [EVAL-ADM1186-2MBZ](#)