

QUICK START GUIDE FOR DEMONSTRATION CIRCUIT 1286 48V OUTPUT BOOST CONVERTER

LTC3862EGN, LTC3862EGN-1

DESCRIPTION

Demonstration circuit 1286A is DC/DC boost converter featuring the LTC®3862EGN constant frequency current mode boost controller. The DC1286A-A operates over 5V to 36V input and provides 2A-5A of output current at 48V output. The DC1286A-B operates over 8V to 36V input and provides 3A-5A of output current at 48V output. The 200kHz constant frequency operation results in small and efficient circuit. The converter provides high output voltage accuracy (typically $\pm 3\%$) over wide load range with no minimum load requirement.

The demonstration circuit can be easily modified to generate different output voltages. Please consult LTC factory for details.

The DC1286A has small circuit footprint. It is a high performance and cost effective solution for Telecom, Automotive and Power Over Ethernet applications.

Design files for this circuit board are available. Call the LTC factory.

PowerPath is a trademark of Linear Technology Corporation

Table 1. Performance Summary

| PARAMETER | CONDITION | VALUE |
|---------------------------------|---------------------------------|----------------------|
| Minimum Input Voltage | $I_{OUT} = 0A$ to 2A | |
| DC1286A-A | | 5V |
| DC1286A-B | | 8V |
| Maximum Input Voltage | $I_{OUT} = 0A$ to 5A | 36V |
| V_{OUT} | $V_{IN} = 12V$, $I_{OUT} = 3A$ | 48V $\pm 3\%$ |
| Typical Output Ripple V_{OUT} | $V_{IN} = 12V$, $I_{OUT} = 4A$ | 400mV _{P-P} |
| Nominal Switching Frequency | | 200kHz |

QUICK START PROCEDURE

Demonstration circuit 1286A is easy to set up to evaluate the performance of the LTC3862. For proper measurement equipment setup refer to Figure 1 and follow the procedure below:

NOTE: When measuring the input or output voltage ripple, care must be taken to minimize the length of oscilloscope probe ground lead. Measure the input or output voltage ripple by connecting the probe tip directly across the VIN or VOUT and GND terminals as shown in Figure 2.

1. With power off, connect the input power supply to Vin and GND.

2. Check the Vcc Bias voltage-setting jumper JP5. Move it into Vin position if required.
3. Turn the input power source on and slowly increase the input voltage. Be careful not to exceed 36V.

NOTE: Make sure that the input voltage Vin does not exceed 36V. If higher operating voltage is required, power components with higher voltage ratings should be used. Also, Jumper JP5 will have to be moved to 12V position.

4. Check for the proper output voltage of 48V.

If there is no output, temporarily disconnect the load to make sure that the load is not set too high.

QUICK START GUIDE FOR DEMONSTRATION CIRCUIT 1286

48V OUTPUT BOOST CONVERTER

- Once the proper output voltage is established, adjust the load and observe the output voltage regulation, ripple voltage, efficiency and other parameters.

OPTIONAL BIAS CIRCUIT

The demo board DC1286A can be used for boosting higher input voltages as well. In that case, the bias power for LTC3862 has to be limited under 36V. An external power source can be used to accomplish this or the optional bias regulator can be used by moving JP4 to 12V position. Since the power dissipation in bias regulator Q5 depends on the size of MOSFETs, switching frequency and voltage difference across Q5 all of the factors need to be considered when selecting the appropriate device for Q5. Please refer to LTC3862 data sheet for bias power requirements.

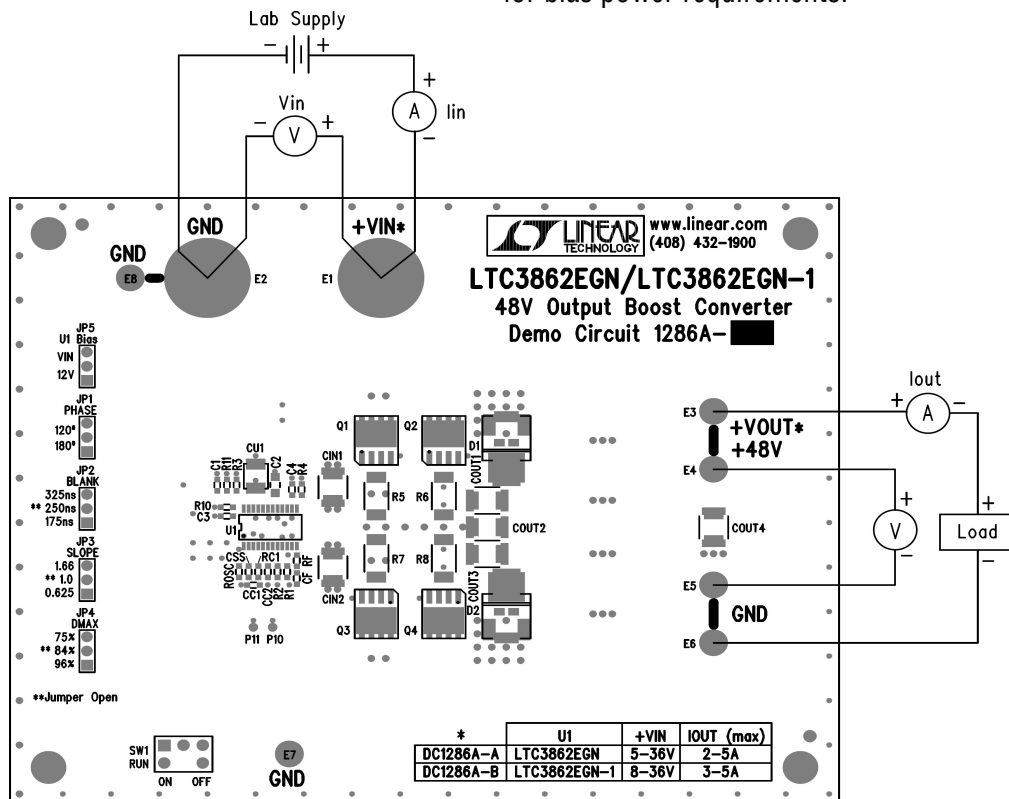

Figure 1. Proper Measurement Equipment Setup

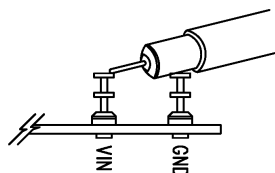

Figure 2. Measuring Input or Output Ripple

CHANGING THE OUTPUT VOLTAGE

To set the output voltage lower than 48V, change the bottom voltage divider resistor connected to LTC3862 FB pin.

To get higher than 48V output voltages MOSFETs and output diodes with higher voltage ratings may be required. Please contact LTC factory for details.

CONVERTER EFFICIENCY AND OUTPUT CURRENT

The DC1286A output current capability depends on the input voltage and proper cooling. Typical performance of DC1286A-A is shown in Figure 3. The efficiency of DC1286A-B which is equipped with 10V gate drive version of PWM controller LTC3862-1 is shown in Figure 4.

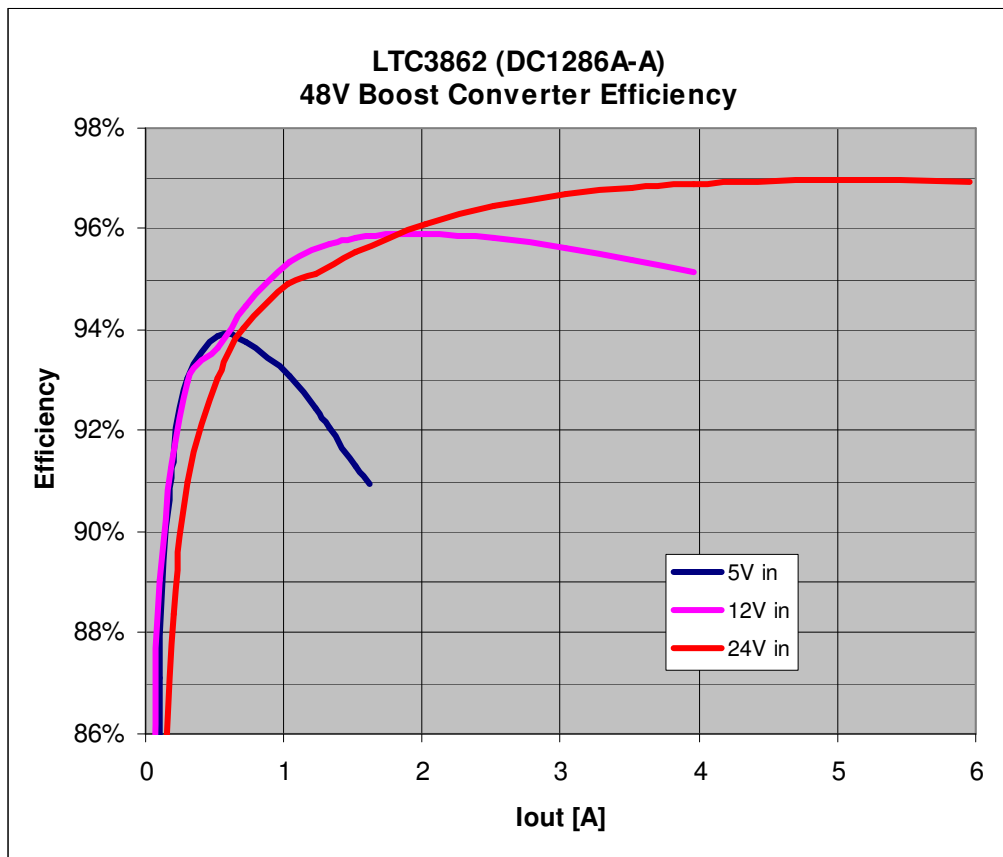

Figure 3. DC1286A-A Efficiency

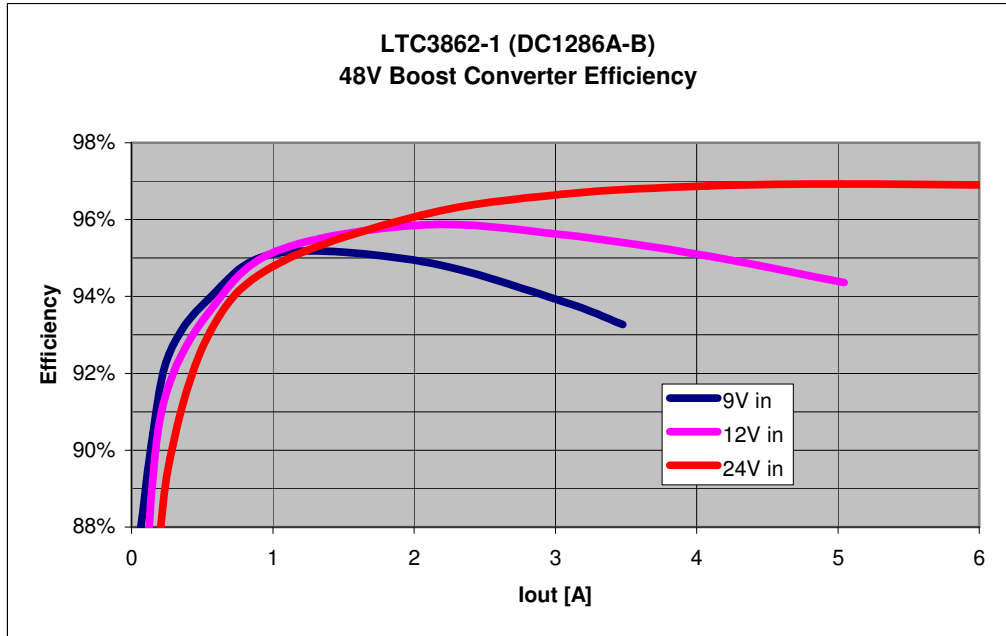

Figure 4. DC1286A-B Efficiency

OUTPUT LOAD STEP RESPONSE

The load step response of DC1286A-A is very fast even though relatively small amount of output capacitance is present at the output. If higher load steps need to be handled more output capacitance can be added in order to keep the voltage transients at the desired level. The load step transients are shown in Figure 5.

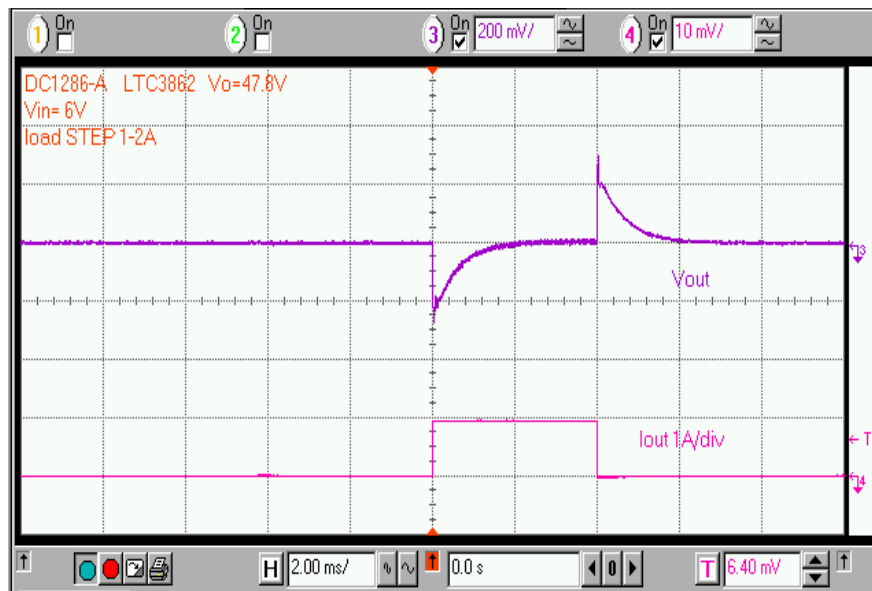
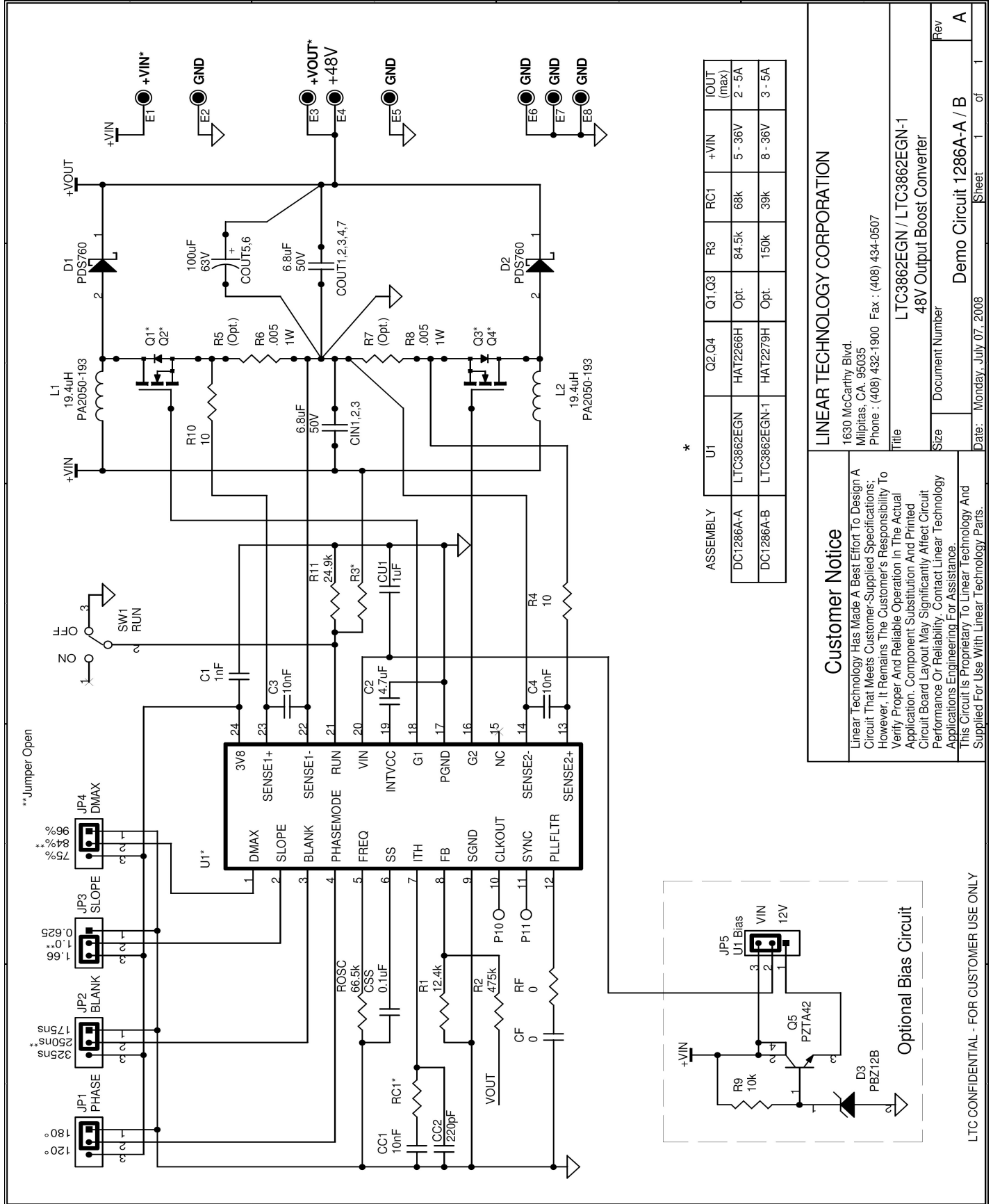

Figure 5. Output Load Step Response

QUICK START GUIDE FOR DEMONSTRATION CIRCUIT 1286

48V OUTPUT BOOST CONVERTER



X-ON Electronics

Largest Supplier of Electrical and Electronic Components

Click to view similar products for [Power Management IC Development Tools](#) category:

Click to view products by [Analog Devices](#) manufacturer:

Other Similar products are found below :

[EVAL-ADM1168LQEBZ](#) [EVB-EP5348UI](#) [MIC23451-AAAYFL EV](#) [MIC5281YMME EV](#) [DA9063-EVAL](#) [ADP122-3.3-EVALZ](#) [ADP130-0.8-EVALZ](#) [ADP130-1.2-EVALZ](#) [ADP130-1.5-EVALZ](#) [ADP130-1.8-EVALZ](#) [ADP1714-3.3-EVALZ](#) [ADP1716-2.5-EVALZ](#) [ADP1740-1.5-EVALZ](#) [ADP1752-1.5-EVALZ](#) [ADP1828LC-EVALZ](#) [ADP1870-0.3-EVALZ](#) [ADP1871-0.6-EVALZ](#) [ADP1873-0.6-EVALZ](#) [ADP1874-0.3-EVALZ](#) [ADP1882-1.0-EVALZ](#) [ADP199CB-EVALZ](#) [ADP2102-1.25-EVALZ](#) [ADP2102-1.875EVALZ](#) [ADP2102-1.8-EVALZ](#) [ADP2102-2-EVALZ](#) [ADP2102-3-EVALZ](#) [ADP2102-4-EVALZ](#) [ADP2106-1.8-EVALZ](#) [ADP2147CB-110EVALZ](#) [AS3606-DB](#) [BQ24010EVM](#) [BQ24075TEVM](#) [BQ24155EVM](#) [BQ24157EVM-697](#) [BQ24160EVM-742](#) [BQ24296MEVM-655](#) [BQ25010EVM](#) [BQ3055EVM](#) [NCV891330PD50GEVB](#) [ISLUSBI2CKIT1Z](#) [LM2744EVAL](#) [LM2854EVAL](#) [LM3658SD-AEV/NOPB](#) [LM3658SDEV/NOPB](#) [LM3691TL-1.8EV/NOPB](#) [LM4510SDEV/NOPB](#) [LM5033SD-EVAL](#) [LP38512TS-1.8EV](#) [EVAL-ADM1186-1MBZ](#) [EVAL-ADM1186-2MBZ](#)