

DESCRIPTION

Demonstration circuit 1289 is a no rsense step-down dc/dc converter featuring the LTC3879EUD. Its output supplies 1.2V @ 15A and its input voltage range is from 4.5V to 14V. The demo board uses a high density, two sided drop-in layout. The power components, excluding the bulk output capacitors and bulk input capacitors, fit within a 0.94" x 0.69" area on the top layer. The control circuit on the bottom layer has a footprint of 0.40" x 0.50".

The fixed on-time valley current mode architecture of the LTC3879EUD provides a very fast load step response. Other features of the board include a RUN pin, a TRACK pin, a PGOOD pin and a MODE jumper to select either CCM or DCM operation at light load.

Design files for this circuit board are available. Call the LTC factory.

Table 1. Performance Summary (T_A = 25°C)

PARAMETER	CONDITION	VALUE
Minimum Input Voltage		4.5V
Maximum Input Voltage		14V
Output Voltage V _{OUT}	V _{IN} = 4.5V to 14V, I _{OUT} = 0A to 15A	1.2V ±2%
Maximum Output Current		15A
Typical Output Voltage Ripple	V _{IN} = 12V, I _{OUT} = 15A (20MHz BW)	18mV _{p-p}
Nominal Switching Frequency	100% load	430kHz
Efficiency (see Figure 3 for efficiency curves)	V _{IN} = 12V, 100% load	87.7% Typical

QUICK START PROCEDURE

Demonstration circuit 1289 is easy to set up to evaluate the performance of the LTC3879EUD. Refer to Figure 1 for proper measurement equipment setup and follow the procedure below:

NOTE: When measuring the input or output voltage ripple, care must be taken to avoid a long ground lead on the oscilloscope probe. See Figure 2 for proper scope probe technique. Short, stiff leads should be soldered to the (+) and (-) terminals of an output capacitor. The probe's ground ring needs to touch the (-) lead and the probe tip needs to touch the (+) lead.

- Place jumpers in the following positions:

RUN	ON
MODE	CCM
- With power off, connect the input power supply to Vin and GND.
- Turn on the power at the input.
- Check for the proper output voltages.
V_{out} = 1.176V to 1.224V
- Once the proper output voltages are established, adjust the loads within the operating range and observe the output voltage regulation, ripple voltage, efficiency and other parameters.

QUICK START GUIDE FOR DEMONSTRATION CIRCUIT 1289

NO RSENSE STEP-DOWN DC/DC CONVERTER

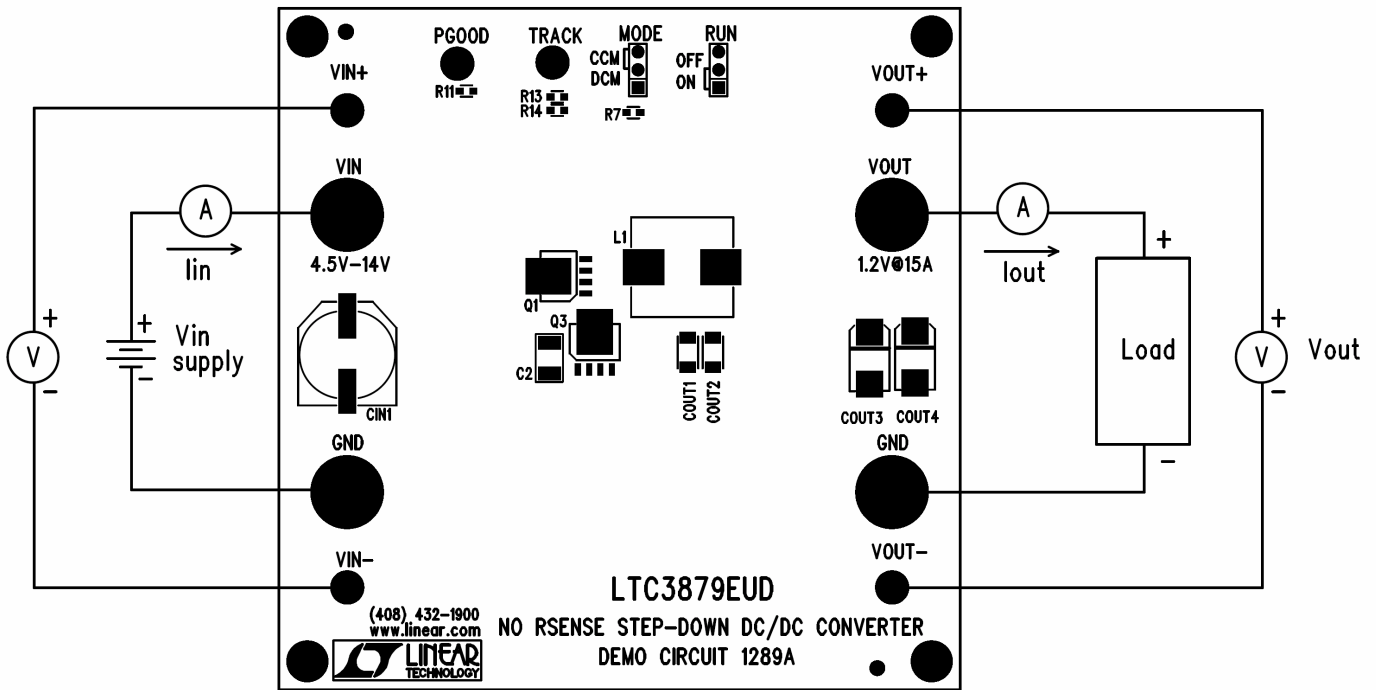

Figure 1. Proper Measurement Equipment Setup

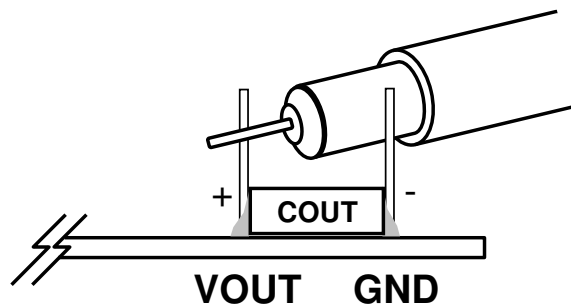

Figure 2. Measuring Output Voltage Ripple

F_{sw} = 430kHz, CCM

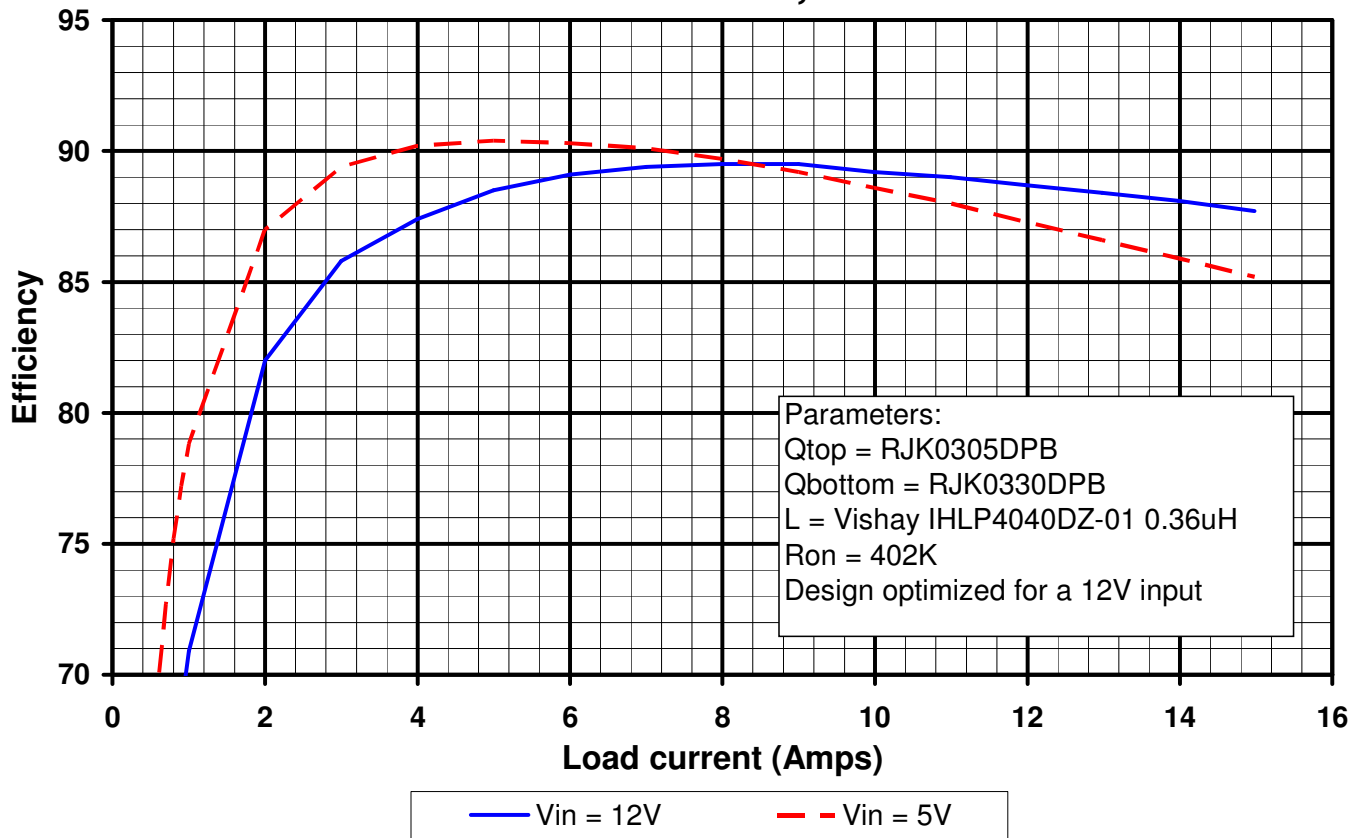
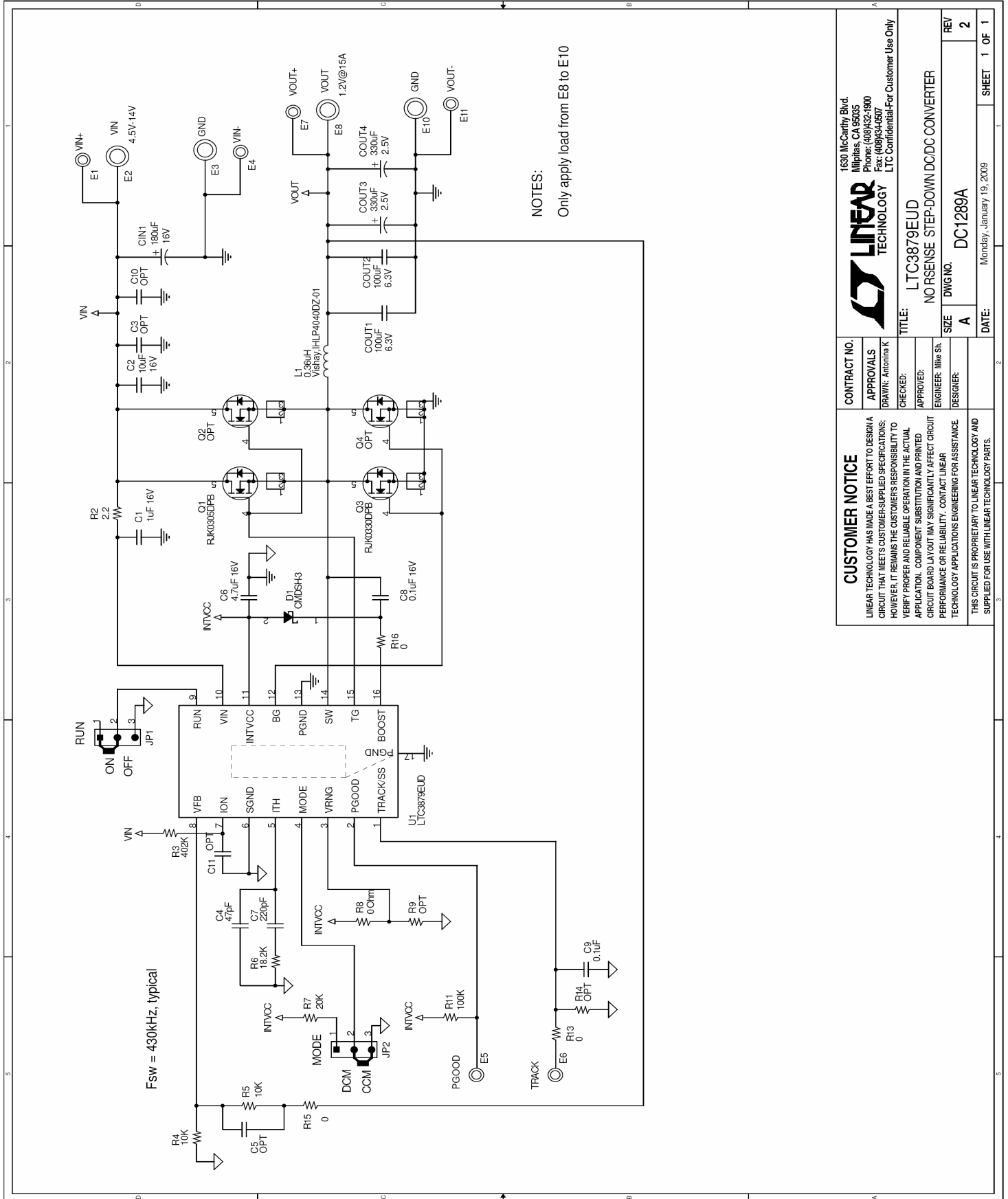

Figure 3. Typical Efficiency Curves

QUICK START GUIDE FOR DEMONSTRATION CIRCUIT 1289

NO RSENSE STEP-DOWN DC/DC CONVERTER



CUSTOMER NOTICE		CONTRACT NO.	
LINEAR TECHNOLOGY HAS MADE A BEST EFFORT TO DESIGN A CIRCUIT THAT MEETS CUSTOMER-SUPPLIED SPECIFICATIONS; HOWEVER, IT REMAINS THE CUSTOMER'S RESPONSIBILITY TO VERIFY PROPER AND RELIABLE OPERATION IN THE ACTUAL APPLICATION. COMPONENT SUBSTITUTION AND PRINTED CIRCUIT BOARD LAYOUT MAY SIGNIFICANTLY AFFECT CIRCUIT PERFORMANCE OR RELIABILITY. CONTACT LINEAR TECHNOLOGY APPLICATIONS ENGINEERING FOR ASSISTANCE.		APPROVALS	
		DRAWN: Antonia K	
		CHECKED:	
		APPROVED:	
		ENGINEER: Mike Sh.	
		DESIGNER:	
		TITLE: LTC3879EUD	
		NO RSENSE STEP-DOWN DC/DC CONVERTER	
		SIZE: A	
		DWG NO: DC1289A	
		DATE: Monday, January 19, 2009	
		SHEET 1 OF 1	

X-ON Electronics

Largest Supplier of Electrical and Electronic Components

Click to view similar products for [Power Management IC Development Tools](#) category:

Click to view products by [Analog Devices](#) manufacturer:

Other Similar products are found below :

[EVAL-ADM1168LQEBZ](#) [EVB-EP5348UI](#) [MIC23451-AAAYFL EV](#) [MIC5281YMME EV](#) [DA9063-EVAL](#) [ADP122-3.3-EVALZ](#) [ADP130-0.8-EVALZ](#) [ADP130-1.2-EVALZ](#) [ADP130-1.5-EVALZ](#) [ADP130-1.8-EVALZ](#) [ADP1714-3.3-EVALZ](#) [ADP1716-2.5-EVALZ](#) [ADP1740-1.5-EVALZ](#) [ADP1752-1.5-EVALZ](#) [ADP1828LC-EVALZ](#) [ADP1870-0.3-EVALZ](#) [ADP1871-0.6-EVALZ](#) [ADP1873-0.6-EVALZ](#) [ADP1874-0.3-EVALZ](#) [ADP1882-1.0-EVALZ](#) [ADP199CB-EVALZ](#) [ADP2102-1.25-EVALZ](#) [ADP2102-1.875EVALZ](#) [ADP2102-1.8-EVALZ](#) [ADP2102-2-EVALZ](#) [ADP2102-3-EVALZ](#) [ADP2102-4-EVALZ](#) [ADP2106-1.8-EVALZ](#) [ADP2147CB-110EVALZ](#) [AS3606-DB](#) [BQ24010EVM](#) [BQ24075TEVM](#) [BQ24155EVM](#) [BQ24157EVM-697](#) [BQ24160EVM-742](#) [BQ24296MEVM-655](#) [BQ25010EVM](#) [BQ3055EVM](#) [NCV891330PD50GEVB](#) [ISLUSBI2CKIT1Z](#) [LM2744EVAL](#) [LM2854EVAL](#) [LM3658SD-AEV/NOPB](#) [LM3658SDEV/NOPB](#) [LM3691TL-1.8EV/NOPB](#) [LM4510SDEV/NOPB](#) [LM5033SD-EVAL](#) [LP38512TS-1.8EV](#) [EVAL-ADM1186-1MBZ](#) [EVAL-ADM1186-2MBZ](#)