

DESCRIPTION

Demonstration Circuit 1304A features two programmable filter ICs, the LTC6602 dual, matched, bandpass filter and the LTC6603, dual, matched, lowpass filter.

**The DC1304A-A is for an LTC6602 and
The DC1304A-B is for an LTC6603.**

The LTC®6602 is a dual, programmable bandpass filter and differential driver. The selectivity of the LTC6602 is ideal for filtering baseband tag signals in RFID systems. The LTC®6603 is a dual, programmable lowpass filter for communications receivers and transmitters in TD-SCDMA, WCDMA, CDMA2000, UMTS and 802.11x systems. A DC1304A-A or -B board has two pairs of SMA connectors for differential inputs and two pairs of SMA connectors for differential outputs. The differential inputs can be AC coupled or DC coupled. On board jumpers provide control of an LTC6602 or an LTC6603. The jumper control settings are: serial or parallel control, internal or external clock, gain and bandwidth control and input AC or DC coupling. An on board multi-turn potentiometer sets the value of the RBIAS resistor that sets the IC power supply current and clock frequency. PCB turrets provide for board connections to an SPI master for a serial control of IC gain and bandwidth.

LTC6602 features:

- Guaranteed Phase and Gain Matching Specs
- Programmable 5th Order Lowpass: 40 kHz to 900 kHz
- Programmable 4th Order Highpass: 4 kHz to 90 kHz
- Programmable Gain (0dB/12dB/24dB/30dB)
- Simple Pin Programming or SPI Interface
- Input Range Extends from 0V to 5V
- Low Voltage Operation: 2.7V to 3.6V
- Shutdown and Mute Mode
- 4mm × 4mm QFN Package

LTC6603 features:

- Guaranteed Phase and Gain Matching Specs
- Programmable 9th Order Lowpass: 24 kHz to 2.5 MHz
- Programmable Gain (0dB/6dB/12dB/24dB)
- Simple Pin Programming or SPI Interface
- Input Range Extends from 0V to 5V
- Low Voltage Operation: 2.7V to 3.6V
- Shutdown Mode
- 4mm × 4mm QFN Package

The LTC6602 BLOCK DIAGRAM

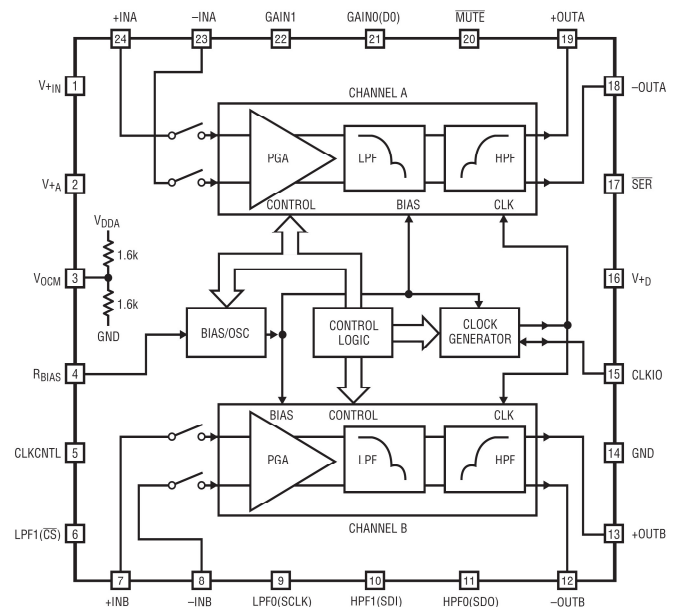

The LTC6603 BLOCK DIAGRAM

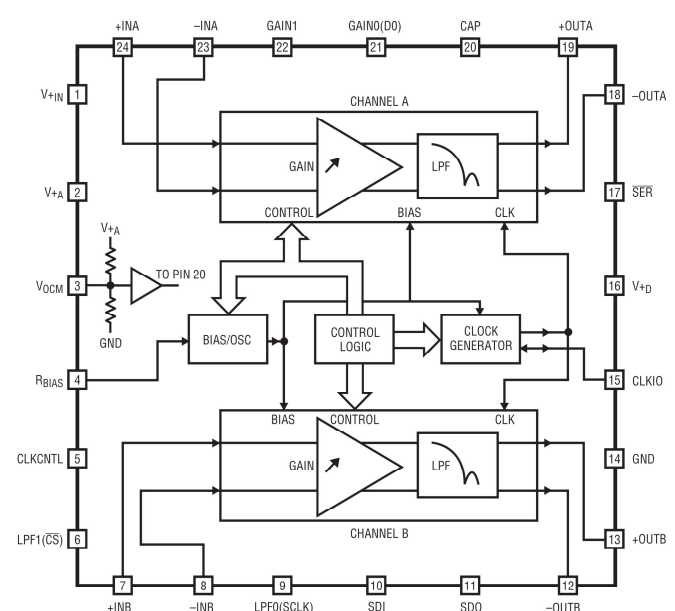

**Design Files for this circuit are available.
Call the LTC factory.**

 , LTC and LT are registered trademarks of Linear Technology Corporation.

DC1304 QUICK START GUIDE

QUICK TEST SETUP – PARALLEL CONTROL

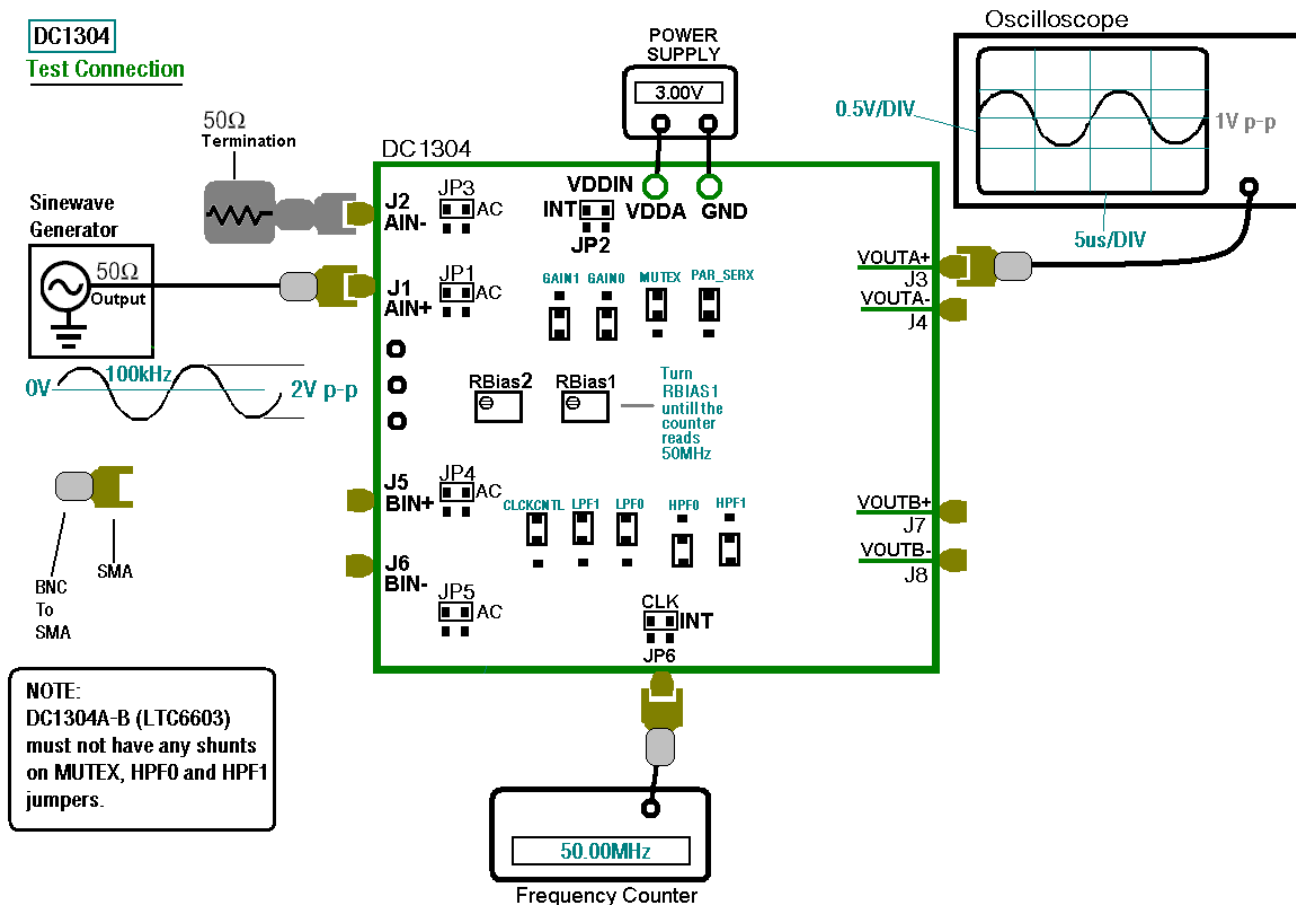

QUICK TEST PROCEDURE

Test Procedure

1. Connect DC1304 as shown, turn on power and adjust the RBIAS1 pot for 50MHz.
2. Connect 50 ohm terminator to AIN-(J2) and sinewave generator to AIN+ (J1).
3. Connect oscilloscope to VOUTA+ and on the oscilloscope display must show a 1Vp-p sinewave.
4. Connect oscilloscope to VOUTA- and on the oscilloscope display must show a 1Vp-p sinewave.
5. Connect 50 ohm terminator to BIN-(J2) and sinewave generator to BIN+ (J1).
6. Connect oscilloscope to VOUTB+ and on the oscilloscope display must show a 1Vp-p sinewave.
7. Connect oscilloscope to VOUTB- and on the oscilloscope display must show a 1Vp-p sinewave.

DC1304 QUICK START GUIDE

LTC6602 FCLK AND FCUTOFF RANGE

FCLK Range, 24MHz to 90MHz

$RBIAS = (4.941 \cdot 10^9) / FCLK$; RBIAS in k

Example: If FCLK = 50 MHz Then

$RBIAS = (4.941 \cdot 10^9) / (50 \cdot 10^6) = 98.82k$

The Lowpass FCUTOFF = $FCLK / NLP$

The Highpass FCUTOFF = $FCLK / NHP$

NLP and NHP are the clock dividers set by the (LPF1, LPF0) and (HPF1, HPF0) inputs respectively.

LPF1	LPF0	NLP	HPF1	HPF0	NHP
0	0	600	0	0	6000
0	1	300	0	1	2000
1	0	100	1	0	1000
1	1	100	1	1	Bypass HPF

Lowpass Filter FCUTOFF Range

NLP	Range
100	240kHz – 900kHz
300	80kHz – 300kHz
600	40kHz – 150kHz

Highpass Filter FCUTOFF Range

NHP	Range
1000	24kHz – 90kHz
2000	12kHz – 45kHz
6000	4kHz – 15kHz

LTC6602 FCLK AND FCUTOFF RANGE

FCLK Range, 12MHz to 80MHz

$RBIAS = (2.472 \cdot 10^9) / FCLK$; RBIAS in k

Example: If FCLK = 50 MHz Then

$RBIAS = (2.472 \cdot 10^9) / (50 \cdot 10^6) = 49.44k$

The Lowpass FCUTOFF = $FCLK / NLP$

NLP clock divider set by the (LPF1, LPF0) inputs.

LPF1	LPF0	NLP
0	0	512
0	1	128
1	0	32
1	1	32

Lowpass Filter FCUTOFF Range

NLP	Range
32	375kHz – 2.5MHz
128	93.75kHz – 625kHz
512	23.44kHz – 156.25kHz

DC1304 QUICK START GUIDE

DC1304 SERIAL CONTROL SETUP

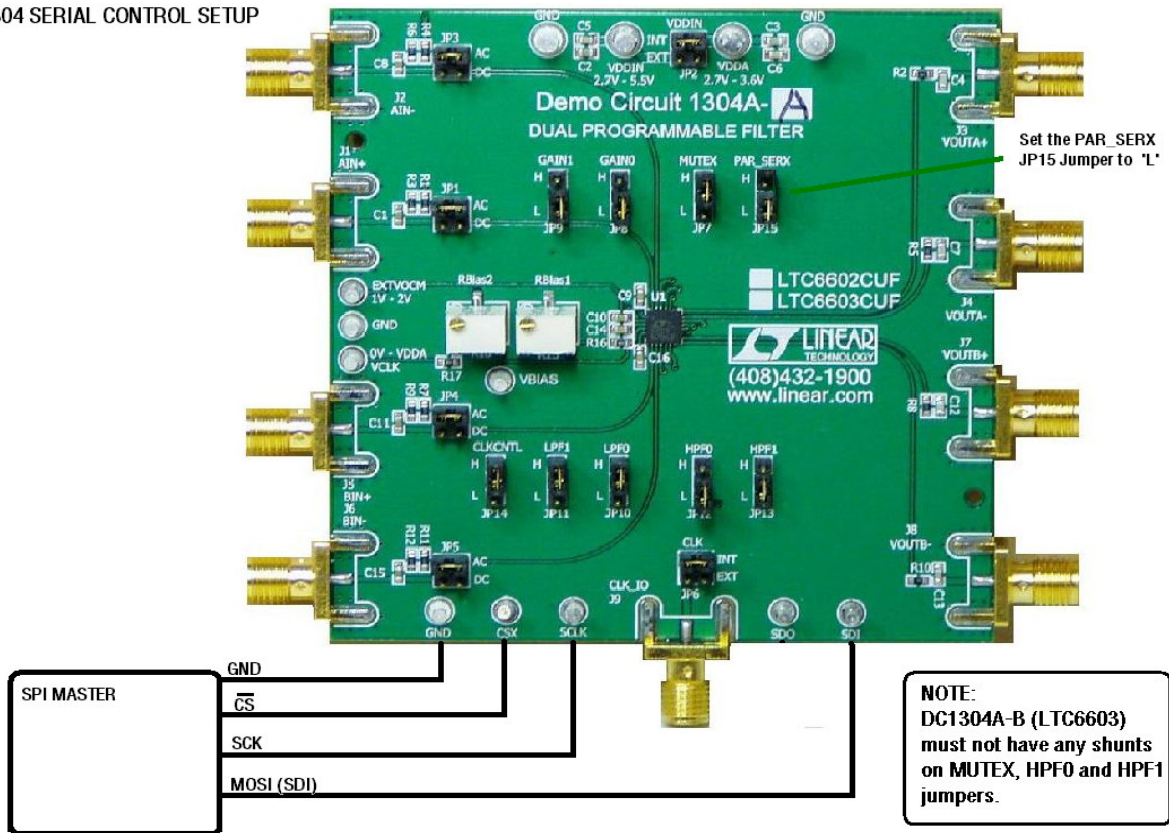

Timing Diagram of the Serial Interface

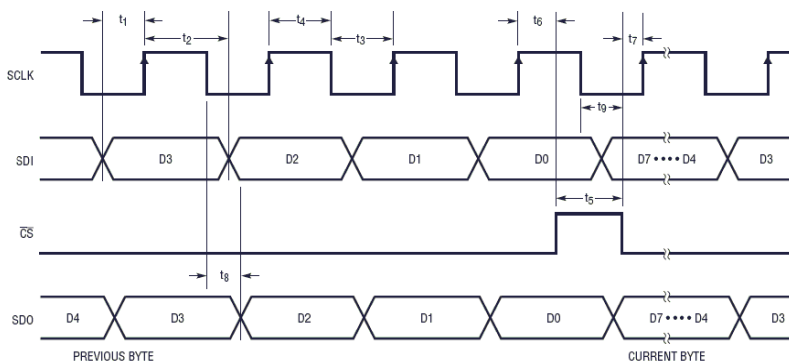

	MIN	MAX	
t_1	SDI Valid to SCLK Setup	60	ns
t_2	SDI Valid to SCLK Hold	0	ns
t_3	SCLK Low	100	ns
t_4	SCLK High	100	ns
t_5	\overline{CS} Pulse Width	60	ns
t_6	LSB SCLK to \overline{CS}	60	ns
t_7	\overline{CS} Low to SCLK	30	ns
t_8	SDO Output Delay	125	ns
t_9	SCLK Low to \overline{CS} Low	0	ns

LTC6602

Serial Control Register Definition

D7	D6	D5	D4	D3	D2	D1	D0
GAIN0	GAIN1	LPF0	LPF1	HPF0	HPF1	SHDN	OUT

LTC6603

Serial Control Register Definition

D7	D6	D5	D4	D3	D2	D1	D0
GAIN0	GAIN1	LPF0	LPF1	NO FUNCTION	NO FUNCTION	SHDN	OUT

DC1304 QUICK START GUIDE

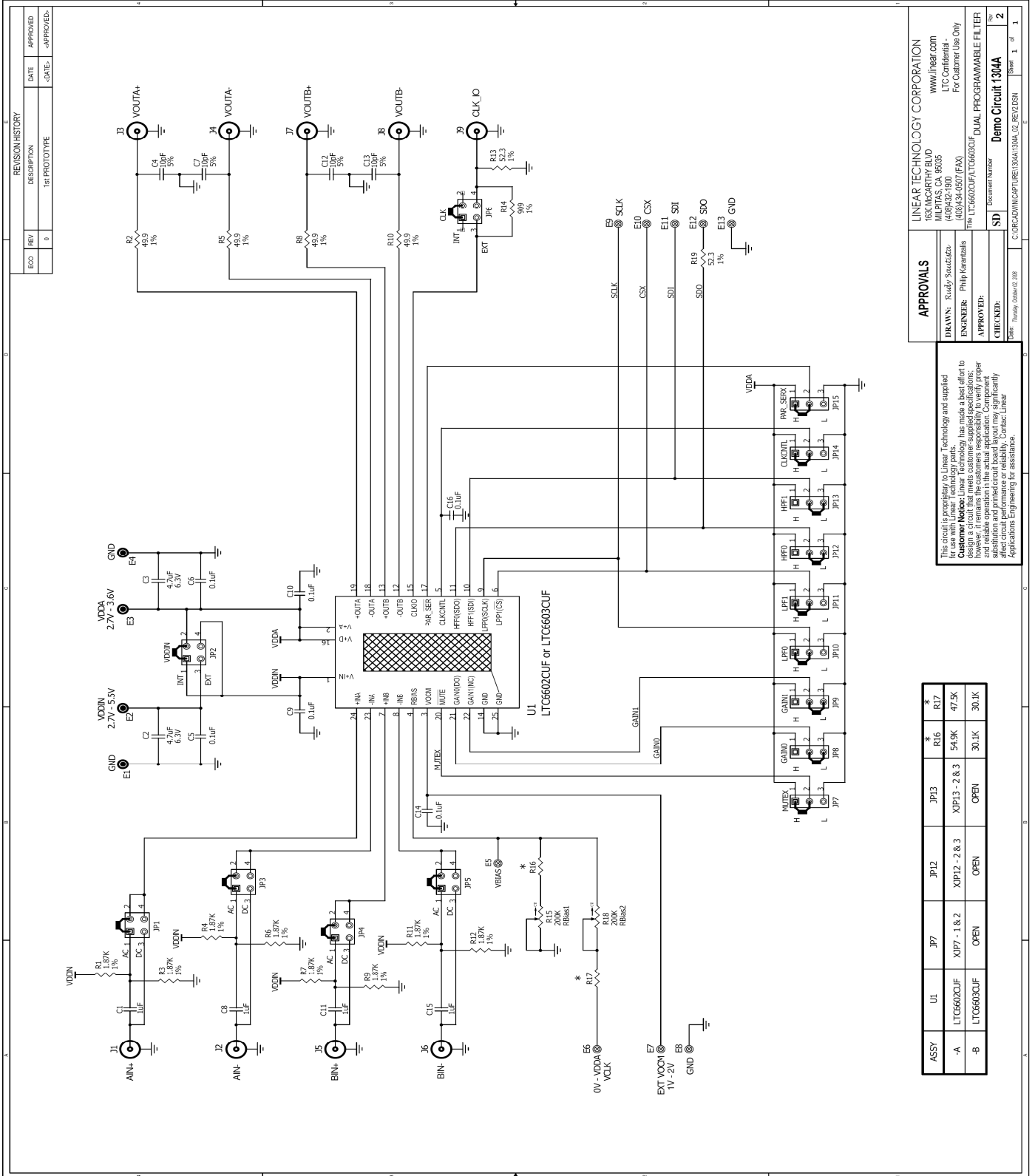

DC1304 QUICK START GUIDE

DC1304A-A PARTS LIST

Item	Qty	Reference	Part Description	Manufacturer / Part #
1	4	C1,C8,C11,C15	Cap., X5R 1uF 25V 20%	AVX 06033D105MAT2A
2	2	C3,C2	Cap., X5R 4.7uF 6.3V 10%	AVX 06036D475KAT1A
3	4	C4,C7,C12,C13	Cap., NPO 10pF 25V 5%	AVX 06033A100JAT2A
4	6	C5,C6,C9,C10,C14,C16	Cap., X7R 0.1uF 25V 10%	AVX 06033C104KAT2A
5	4	E1,E2,E3,E4	Turret, Testpoint	Mill Max 2501-2-00-80-00-00-07-0
6	9	E5,E6,E7,E8,E9,E10,E11, E12,E13	Turret, Testpoint	Mill Max 2308-2-00-80-00-00-07-0
7	6	JP1,JP2,JP3,JP4,JP5,JP6	Headers, 4 Pins 2mm Ctrs.	Samtec TMM-102-02-L-D
8	9	JP7,JP8,JP9,JP10,JP11, JP12,JP13,JP14,JP15	Headers, 3 Pins 2mm Ctrs.	Samtec TMM-103-02-L-S
9	9	J1,J2,J3,J4,J5,J6,J7,J8,J9	Conn., SMA 50-Ohm	Connex 132357
10	1	R16	Res., Chip 54.9K 0.06W 1%	Vishay CRCW060354K9FKEA
11	1	R17	Res., Chip 47.5K 0.06W 1%	Vishay CRCW060347K5FKEA
12	8	R1,R3,R4,R6,R7,R9,R11,R12	Res., Chip 1.87K 0.06W 1%	Vishay CRCW06031K87FKEA
13	4	R2,R5,R8,R10	Res., Chip 49.9 0.06W 1%	Vishay CRCW060349R9FKEA
14	2	R13,R19	Res., Chip 52.3 0.06W 1%	Vishay CRCW060352R3FKEA
15	1	R14	Res., Chip 909 0.06W 1%	Vishay CRCW0603909RFKEA
16	2	R18,R15	Trimpot Vert. Mount 200K	VISHAY TS63Y-204-K-TR250
17	2	R16,R17	Res., Chip 20.0K 0.06W 1%	Vishay CRCW060320K0FKEA
18	1	U1	I.C., OpAmp	LTC6602CUF
19	15	XJP1,XJP2,XJP3,XJP4,XJP5, XJP6,XJP7,XJP8,XJP9, XJP10,XJP11,XJP12,XJP13 XJP14,XJP15	Shunt, 2mm Ctrs.	Samtec 2SN-BK-G

DC1304A-B PARTS LIST

Item	Qty	Reference	Part Description	Manufacturer / Part #
1	4	C1,C8,C11,C15	Cap., X5R 1uF 25V 20%	AVX 06033D105MAT2A
2	2	C3,C2	Cap., X5R 4.7uF 6.3V 10%	AVX 06036D475KAT1A
3	4	C4,C7,C12,C13	Cap., NPO 10pF 25V 5%	AVX 06033A100JAT2A
4	6	C5,C6,C9,C10,C14,C16	Cap., X7R 0.1uF 25V 10%	AVX 06033C104KAT2A
5	4	E1,E2,E3,E4	Turret, Testpoint	Mill Max 2501-2-00-80-00-00-07-0
6	9	E5,E6,E7,E8,E9,E10,E11, E12,E13	Turret, Testpoint	Mill Max 2308-2-00-80-00-00-07-0
7	6	JP1,JP2,JP3,JP4,JP5,JP6	Headers, 4 Pins 2mm Ctrs.	Samtec TMM-102-02-L-D
8	9	JP7,JP8,JP9,JP10,JP11, JP12,JP13,JP14,JP15	Headers, 3 Pins 2mm Ctrs.	Samtec TMM-103-02-L-S
9	9	J1,J2,J3,J4,J5,J6,J7,J8,J9	Conn., SMA 50-Ohm	Connex 132357
10	2	R16,R17	Res., Chip 30.1K 0.06W 1%	Vishay CRCW060330K1FKEA
11	8	R1,R3,R4,R6,R7,R9,R11, R1	Res., Chip 1.87K 0.06W 1%	Vishay CRCW06031K87FKEA
12	4	R2,R5,R8,R10	Res., Chip 49.9 0.06W 1%	Vishay CRCW06049R9FKEA
13	2	R13,R19	Res., Chip 52.3 0.06W 1%	Vishay CRCW060352R3FKEA
14	1	R14	Res., Chip 909 0.06W 1%	Vishay CRCW0603909RFKEA
15	2	R18,R15	Trimpot Vert. Mount 200K	VISHAY TS63Y-204-K-TR250
16	1	U1	I.C., OpAmp	LTC6603CUF
17	12	XJP1,XJP2,XJP3,XJP4,XJP5, XJP6,XJP8,XJP9, XJP10,XJP11,XJP14,XJP15	Shunt, 2mm Ctrs.	Samtec 2SN-BK-G

X-ON Electronics

Largest Supplier of Electrical and Electronic Components

Click to view similar products for [Active Filter Development Tools](#) category:

Click to view products by [Analog Devices](#) manufacturer:

Other Similar products are found below :

[MAXFILTERBRD+](#) [DC1418A-A](#) [DC962A-B](#) [DC962A-E](#) [DC962A-A](#) [DC338B-B](#) [131200-HMC900LP5E](#) [EKIT01-HMC1023LP5](#)
[EVAL01-HMC1044LP3E](#) [AFS1410-EVAL](#) [AFS2016-EVAL](#) [ADMV8432-EVALZ](#) [DC048A](#) [DC1251A-B](#) [DC1418A-B](#) [DC1418A-C](#)
[DC1418A-D](#) [DC962A-D](#) [EV1HMC881ALP5](#) [EV1HMC882ALP5](#) [EV1HMC891ALP5](#) [EVAL-FW-HPMFB2](#) [EVAL-FW-LPMFB2](#) [3-109-440](#) [3-111-353](#) [EVAL-FW-BPDF2](#) [EVAL-FW-HPMFB1](#) [EVAL-FW-HPSK2](#) [DC1251A-A](#) [3-115-037](#) [TPS7A3501EVM-547](#)