

DESCRIPTION

Demonstration circuit 1311 is a Telecom isolated DC/DC converter featuring the LTC3805/-5 constant frequency current mode flyback controller. The DC1311 converts 18V to 72V input voltage to an isolated 3A of output current at 3.3V. The 300kHz constant frequency operation is maintained down to very light load to reduce low frequency noise generated over a wide range of load current. The converter provides high output voltage accuracy (typically $\pm 2\%$) over wide load range with no minimum load requirement.

The DC1311 also provides non-isolated design by removing opto coupler and LTC4430 circuit. The demonstration circuit can be easily modified to generate different output voltages up to 15V. As

output voltage is increased, the maximum output current must be reduced to limit the output power to no more than 10W. Higher output voltages and currents can be achieved by changing the MOSFET, transformer and output capacitors. Please consult LTC factory for details.

The DC1311 has a small circuit footprint. It is a high performance and cost effective solution for Telecom, Automotive and Power over Ethernet applications.

Design files for this circuit board are available. Call the LTC factory.

LTC and LT are registered trademarks of Linear Technology Corporation.

QUICK START PROCEDURE

Demonstration circuit 1311 is easy to set up to evaluate the performance of the LTC3805/-5. For proper measurement equipment setup refer to Figure 1 and follow the procedure below.

When measuring the input or output voltage ripple, care must be taken to minimize the length of the oscilloscope probe ground lead. Measure the input or output voltage ripple by connecting the probe tip directly across the V_{IN} or V_{OUT} and GND terminals, see Figure 2.

1. With power off, connect the input power supply to +Vin and -Vin.
2. Move the J1 (RUN) switch to ON position.
3. Turn the input power source on and slowly increase the input voltage. Be careful not to exceed 72V. Make sure that the input voltage V_{IN} does not exceed 72V. If higher operating voltage is required,

power components with higher voltage ratings should be used.

4. Check for proper output voltage. $V_{out}=3.3V$.

If there is no output, temporarily disconnect the load to make sure that the load is not set too high.

5. To shut the converter down, move the RUN switch into OFF position
6. To synchronize converter to external clock, set jumper JP2 (SYNC) to 'EXT' position, apply signal to FSET pin. See LTC3805/-5 datasheet for synchronization signal parameters.
7. Once the proper output voltage is established, adjust the load within 3.0A range and observe the output voltage regulation, ripple voltage, efficiency and other parameters.

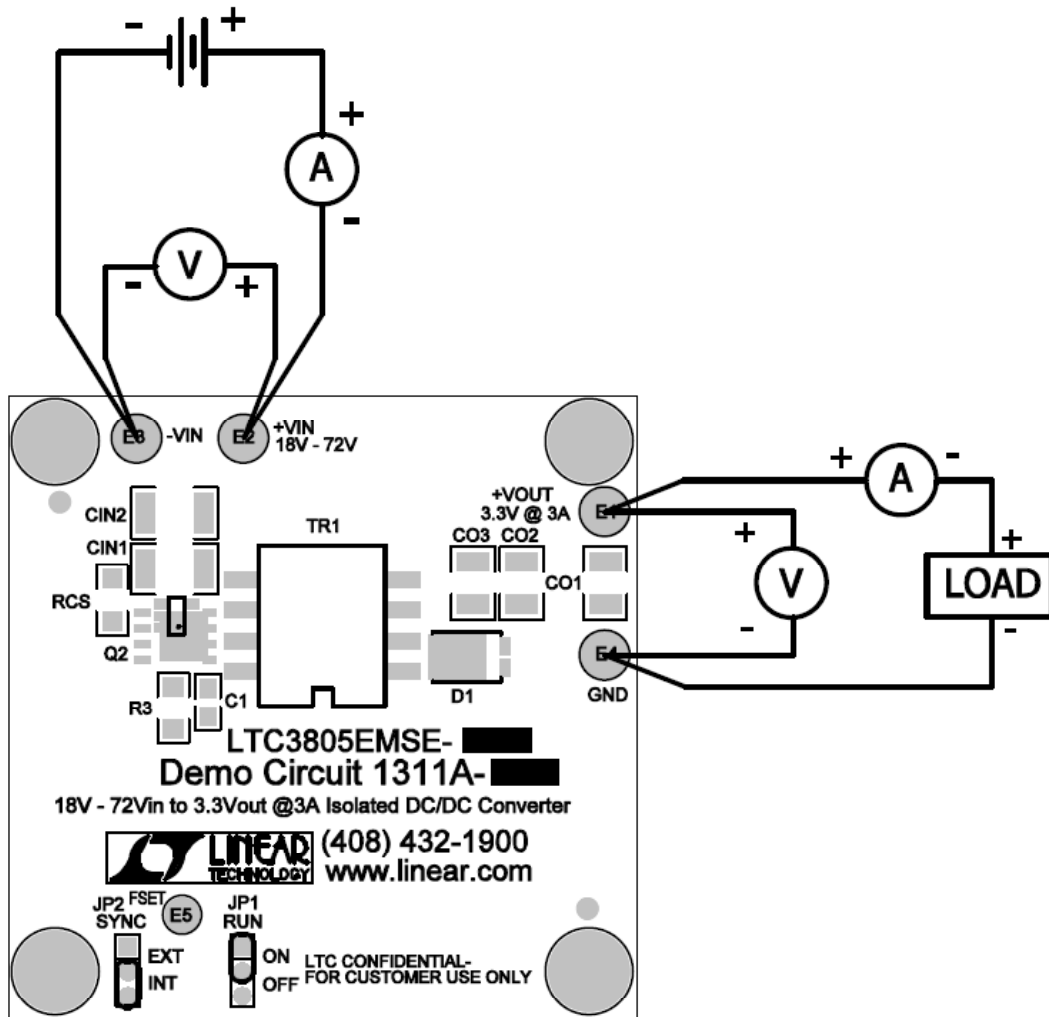

Figure 1. Proper Measurement Equipment Setup

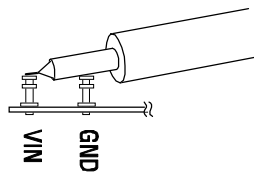
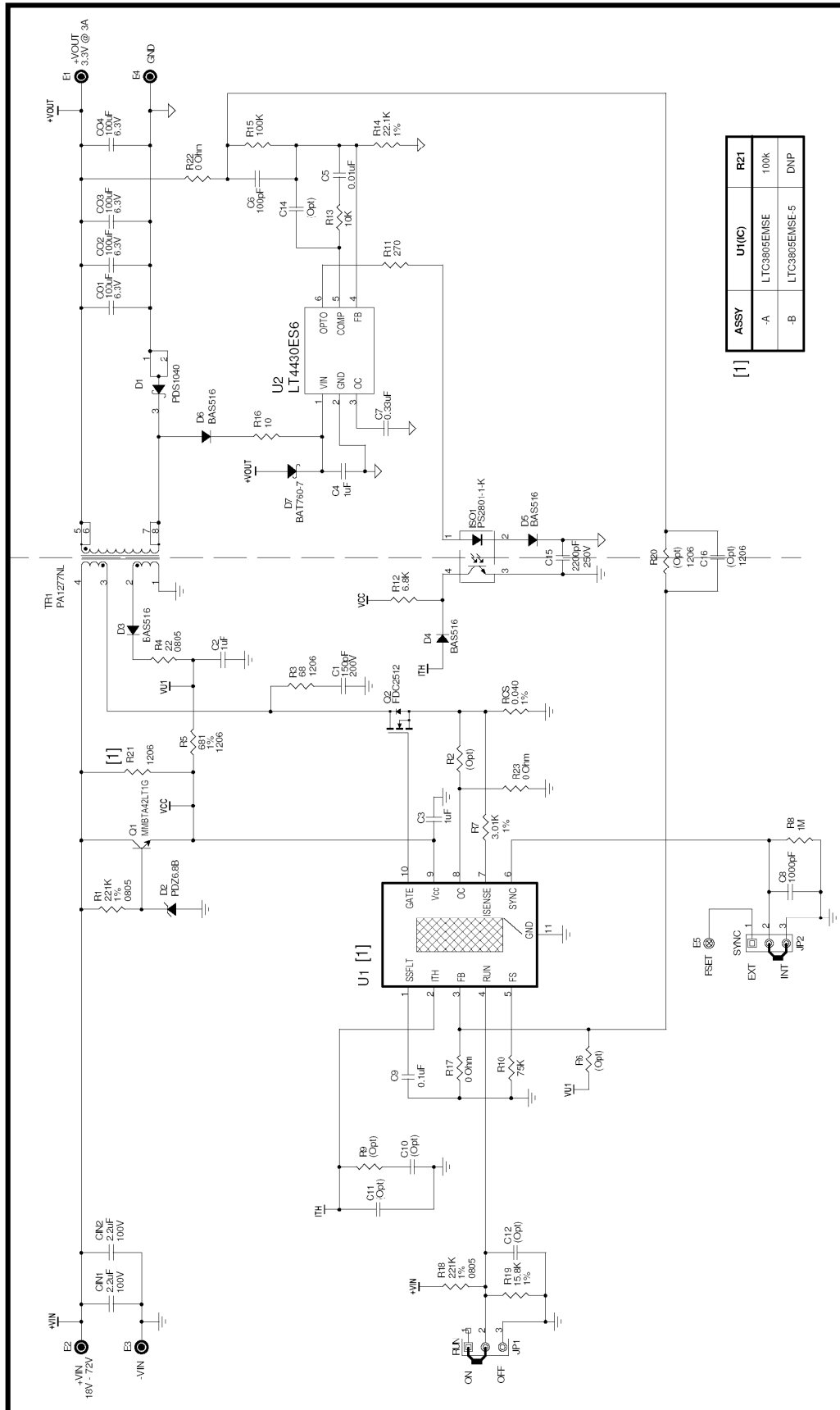

Figure 2. Measuring Input or Output Ripple

QUICK START GUIDE FOR DEMONSTRATION CIRCUIT 1311

TELECOM DC/DC CONVERTER



X-ON Electronics

Largest Supplier of Electrical and Electronic Components

Click to view similar products for [Power Management IC Development Tools](#) category:

Click to view products by [Analog Devices](#) manufacturer:

Other Similar products are found below :

[EVAL-ADM1168LQEBZ](#) [EVB-EP5348UI](#) [MIC23451-AAAYFL EV](#) [MIC5281YMME EV](#) [DA9063-EVAL](#) [ADP122-3.3-EVALZ](#) [ADP130-0.8-EVALZ](#) [ADP130-1.2-EVALZ](#) [ADP130-1.5-EVALZ](#) [ADP130-1.8-EVALZ](#) [ADP1714-3.3-EVALZ](#) [ADP1716-2.5-EVALZ](#) [ADP1740-1.5-EVALZ](#) [ADP1752-1.5-EVALZ](#) [ADP1828LC-EVALZ](#) [ADP1870-0.3-EVALZ](#) [ADP1871-0.6-EVALZ](#) [ADP1873-0.6-EVALZ](#) [ADP1874-0.3-EVALZ](#) [ADP1882-1.0-EVALZ](#) [ADP199CB-EVALZ](#) [ADP2102-1.25-EVALZ](#) [ADP2102-1.875EVALZ](#) [ADP2102-1.8-EVALZ](#) [ADP2102-2-EVALZ](#) [ADP2102-3-EVALZ](#) [ADP2102-4-EVALZ](#) [ADP2106-1.8-EVALZ](#) [ADP2147CB-110EVALZ](#) [AS3606-DB](#) [BQ24010EVM](#) [BQ24075TEVM](#) [BQ24155EVM](#) [BQ24157EVM-697](#) [BQ24160EVM-742](#) [BQ24296MEVM-655](#) [BQ25010EVM](#) [BQ3055EVM](#) [NCV891330PD50GEVB](#) [ISLUSBI2CKIT1Z](#) [LM2744EVAL](#) [LM2854EVAL](#) [LM3658SD-AEV/NOPB](#) [LM3658SDEV/NOPB](#) [LM3691TL-1.8EV/NOPB](#) [LM4510SDEV/NOPB](#) [LM5033SD-EVAL](#) [LP38512TS-1.8EV](#) [EVAL-ADM1186-1MBZ](#) [EVAL-ADM1186-2MBZ](#)