

## DESCRIPTION

Demonstration circuit 1351B is a high-power supply featuring the LTC®4269IDKD-2. This board acts as an IEEE 802.3at compliant, high power Power-over-Ethernet (PoE), Powered Device (PD) and connects at the RJ45 to a compatible high power Power Sourcing Equipment (PSE) device, such as the DC1366A.

The LTC4269IDKD-2 provides IEEE802.3at standard (PoE+) PD interfacing and power supply control. When the PD is fully powered, the PD interface switches power over from the PSE to the switcher through an internal, low resistance, high power MOSFET. The highly integrated LTC4269IDKD-2 controls a high-

power, small-sized power supply that utilizes a highly-efficient isolated forward topology with synchronous rectification. The DC1351B supplies a 5V output at up to 5A.

DC1351B also demonstrates the use of an auxiliary 48V wall adapter. When present, the auxiliary supply becomes the dominant supply over PoE to provide power.

**Design files for this circuit board are available. Call the LTC factory.**

LT, LTC and LT are registered trademarks of Linear Technology Corporation.

**Table 1. Performance Summary (T<sub>A</sub> = 25°C)**

PARAMETER	CONDITION	VALUE
Port Voltage (V <sub>PORT</sub> )	At Ethernet port	37V – 57V
Auxiliary Voltage (V <sub>AUX</sub> )	From Aux- to Aux+ terminals	44V – 57V
Output Voltage (V <sub>OUT</sub> ) Initial Set-point	V <sub>PORT</sub> = 37V to 57V, I <sub>OUT</sub> = 0A to 5A	5.05V ± 1%
Maximum Output Current	V <sub>PORT</sub> = 42V	4.6A (min)
Typical Output Voltage Ripple	V <sub>IN</sub> = 50V, I <sub>OUT</sub> = 4.6A	40mV <sub>P-P</sub> (typ)
Output Regulation	Over Entire Input Voltage and Output Current Range	< ±0.1% (typ)
Load Transient Response	Peak to Peak Deviation with Load Step of 2.5A to 5A	±120mV (< ±2.5%) (typ)
	Settling Time (within 1% of V <sub>OUT</sub> )	150us (typ)
Switching Frequency		225kHz (typ)
Efficiency	V <sub>PORT</sub> = 42V, I <sub>OUT</sub> = 5A, not incl. diode bridge	92.5% (typ)

## OPERATING PRINCIPLES

A compatible high power PSE board, such as the DC1366A, is connected to the DC1351B at the RJ45 connector J2 (see the schematic). As required by IEEE802.3at, a diode bridge is used across the data pairs and signal pairs. Schottky

diodes (D5-8, D12-15) are used at the input to improve efficiency over standard diode bridges. The LTC4269IDKD-2 provides an IEEE802.3at standard PoE 25k signature resistance and is set for a power class 4. When the PD is pow-

ered and voltage is above the PoE “On Voltage”, the LTC4269IDKD-2 switches the port voltage over to the power supply controller through its internal MOSFET which lies between the  $V_{PORTN}$  and  $V_{NEG}$  pins. This voltage charges C11 through a trickle charge resistor, R3 to power the bias pin,  $V_{in}$ , of the power supply controller. Once the bias power gets to its  $V_{IN(ON)}$  threshold, the IC begins a controlled soft-start of the output. As this voltage rises, bias power is taken over by T2, D1/2, and L1.

When the soft-start period is over, the output voltage is regulated by the combination of the

optoisolator (U2) and the reference/error amplifier (D21) pulling down on the COMP pin. The OUT and SOUT pins which drive Q3 and Q2, respectively, are Pulse Width Modulated (PWM) in order to keep the output voltage constant. The synchronous rectifiers (Q4 and Q5) on the secondary side are self-driven by T2. This reduces the gate drive part’s count and complexity since no external driver ICs or delay circuits are needed to achieve synchronous rectification. The high efficiency that is expected with synchronous rectification is maintained.

## QUICK START PROCEDURE

Demonstration circuit 1351B is easy to set up to evaluate the performance of the LTC4269IDKD-2 in a PoE+ PD application. Refer to Figure 1 for proper equipment setup and follow the procedure below:

**NOTE:** When measuring the input or output voltage ripple, care must be taken to avoid a long ground lead on the oscilloscope probe. Measure the output (or input) voltage ripple by touching the probe tip and probe ground directly across the +VOUT and –VOUT (or  $V_{PORT\_P}$  and  $V_{PORT\_N}$ ) terminals. See Figure 2 for proper scope probe technique.

1. Place test equipment (voltmeter, ammeter, and electronic load) across output.

2. Input supplies:

- a. Connect a PoE+ capable PSE with a CAT-5 cable to the RJ45 connector, J2. See Figure 1.
  - b. Or, connect a 37V to 57V capable power supply (“Power Supply” in Figure 1) across  $V_{PORT\_P}$  and  $V_{PORT\_N}$ .
  - c. If evaluating the auxiliary power supply (“Auxiliary Supply” in Figure 1) capability, connect a 44V to 57V capable power supply across AUX+ to AUX-.
3. Check for the proper output voltage of 5V.
4. Once the proper output voltage is confirmed, adjust the load within the operating range and observe the output voltage regulation, ripple voltage, efficiency and other parameters.

# QUICK START GUIDE FOR DEMONSTRATION CIRCUIT 1351B

## SINGLE OUTPUT, HIGH POWER, HIGH EFFICIENCY POE

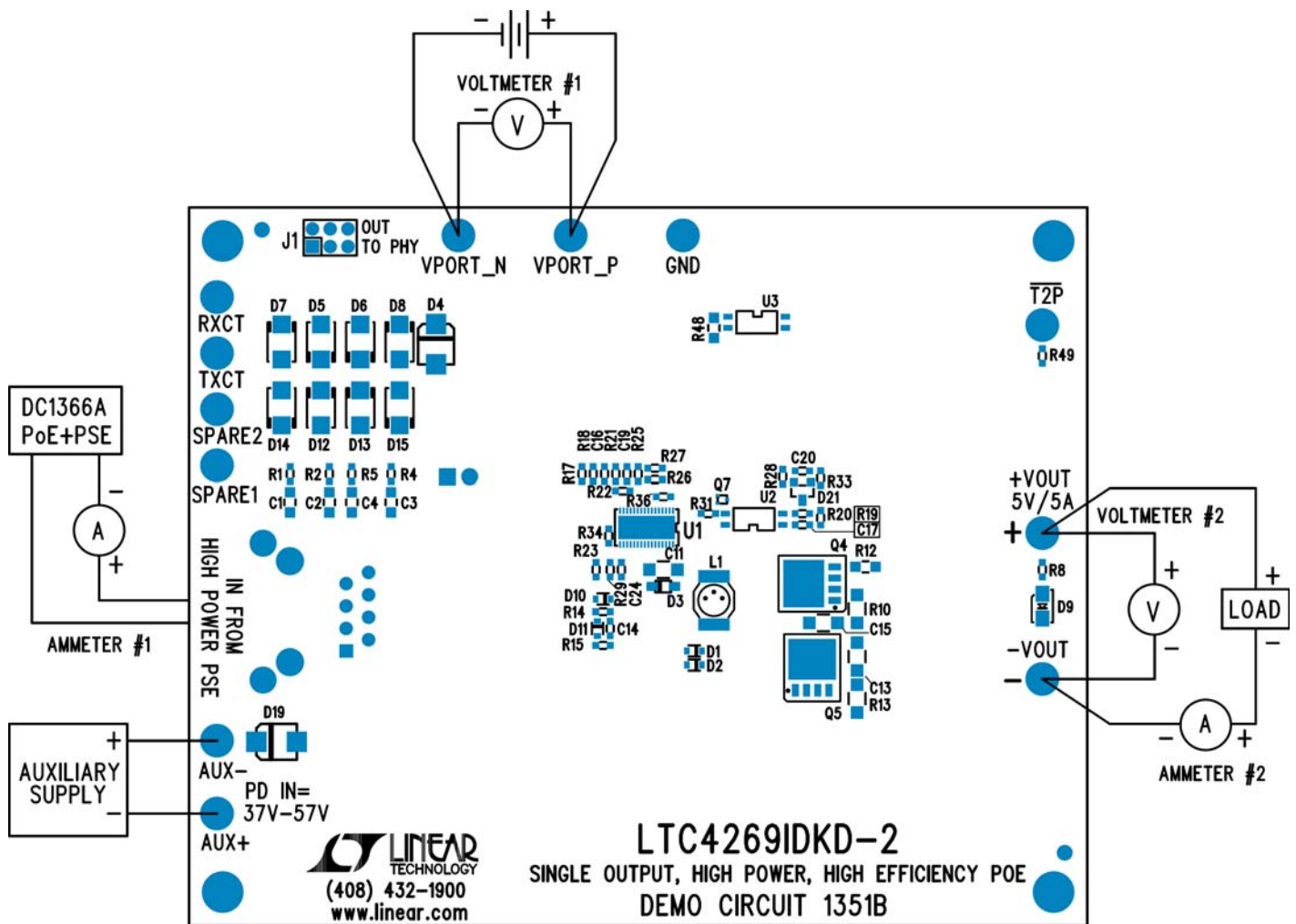

Figure 1. Proper Measurement Equipment Setup

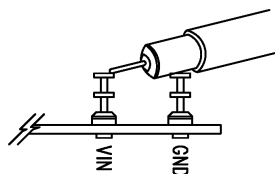

Figure 2. Measuring Input or Output Ripple

## MEASURED DATA

Figures 3 through 12 are measured data for a typical DC1351B.

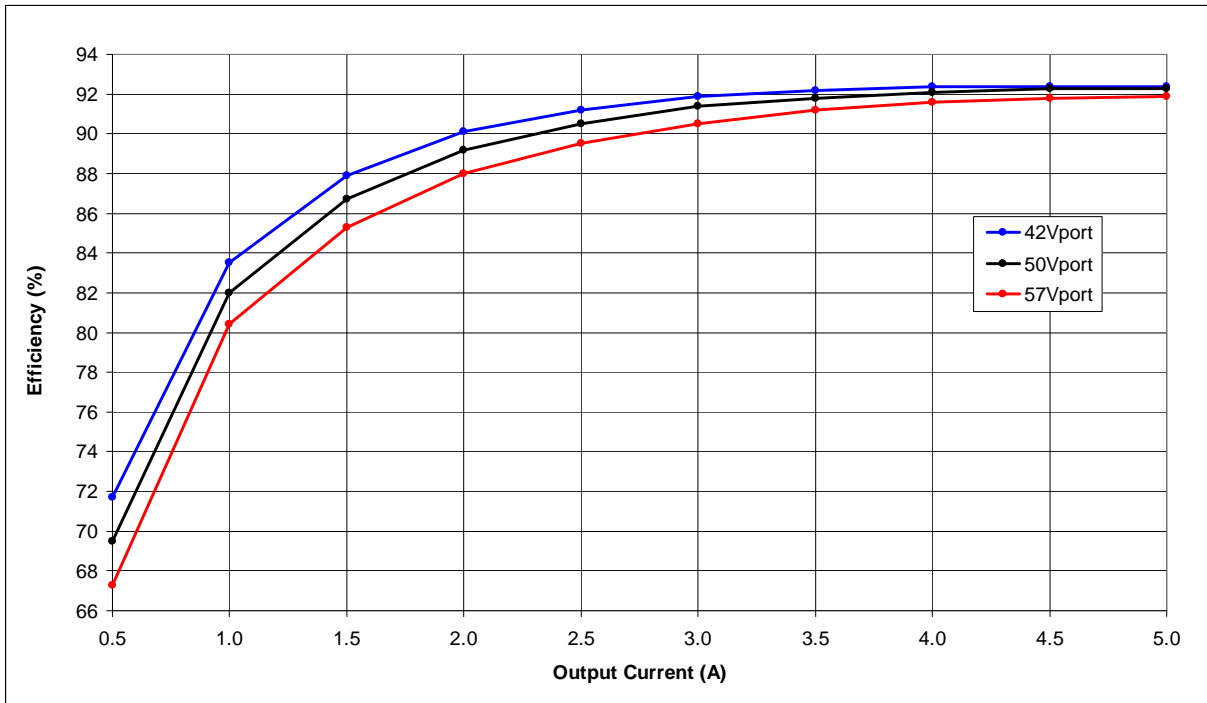

Figure 3. Efficiency

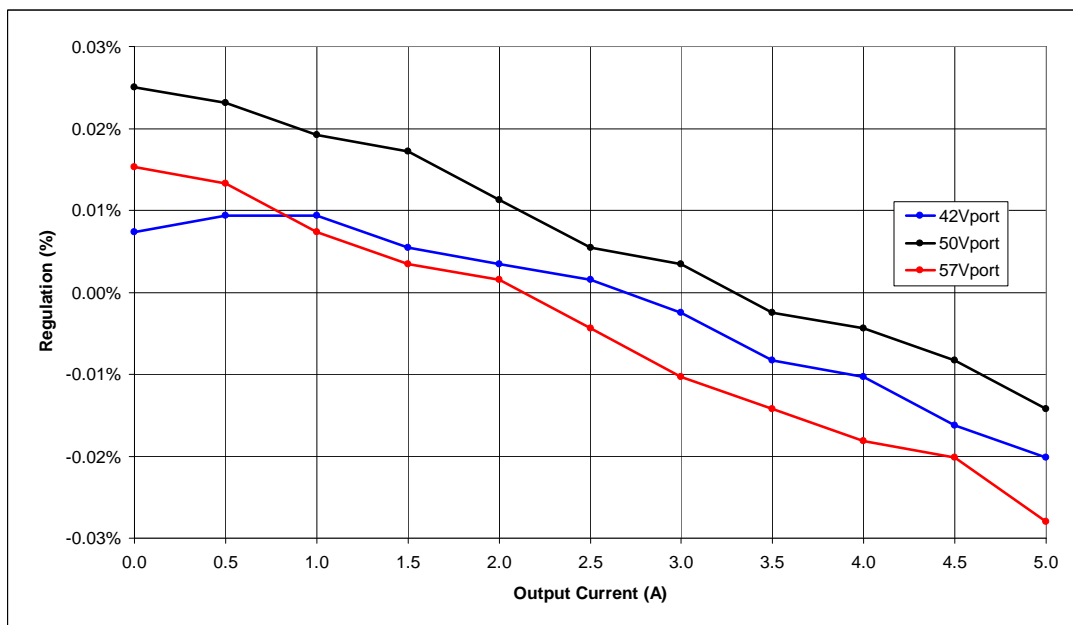

Figure 4. Regulation

# QUICK START GUIDE FOR DEMONSTRATION CIRCUIT 1351B

## SINGLE OUTPUT, HIGH POWER, HIGH EFFICIENCY POE

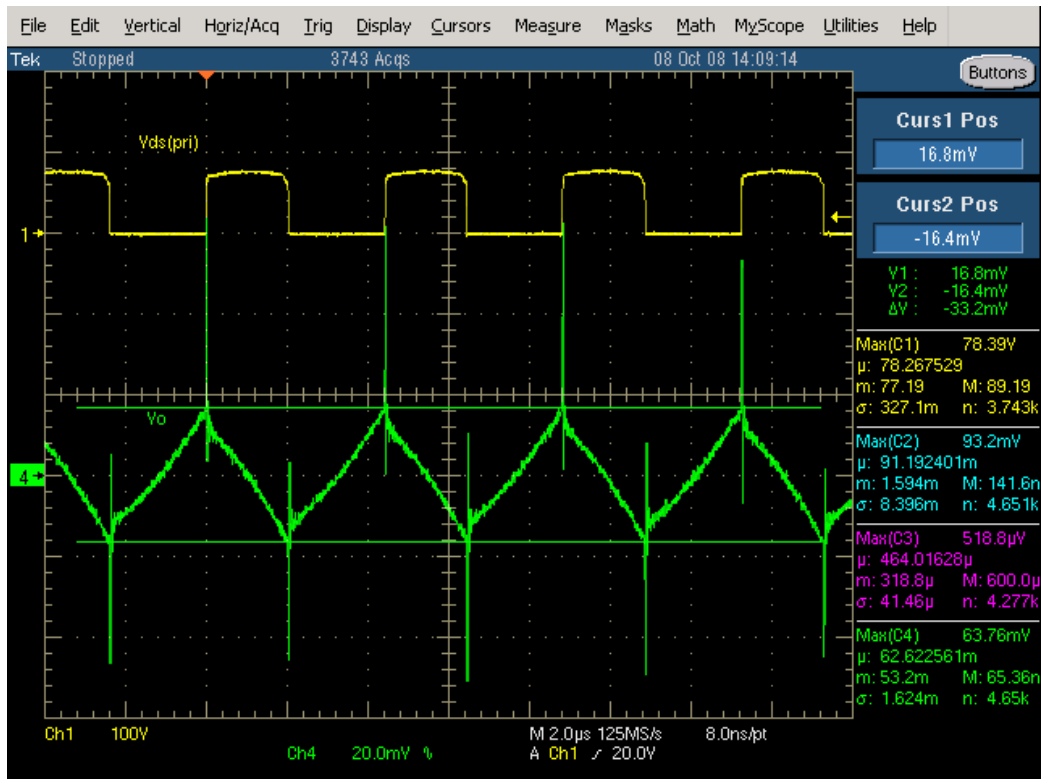

Figure 5. Output Voltage Ripple (37Vport, 5A)

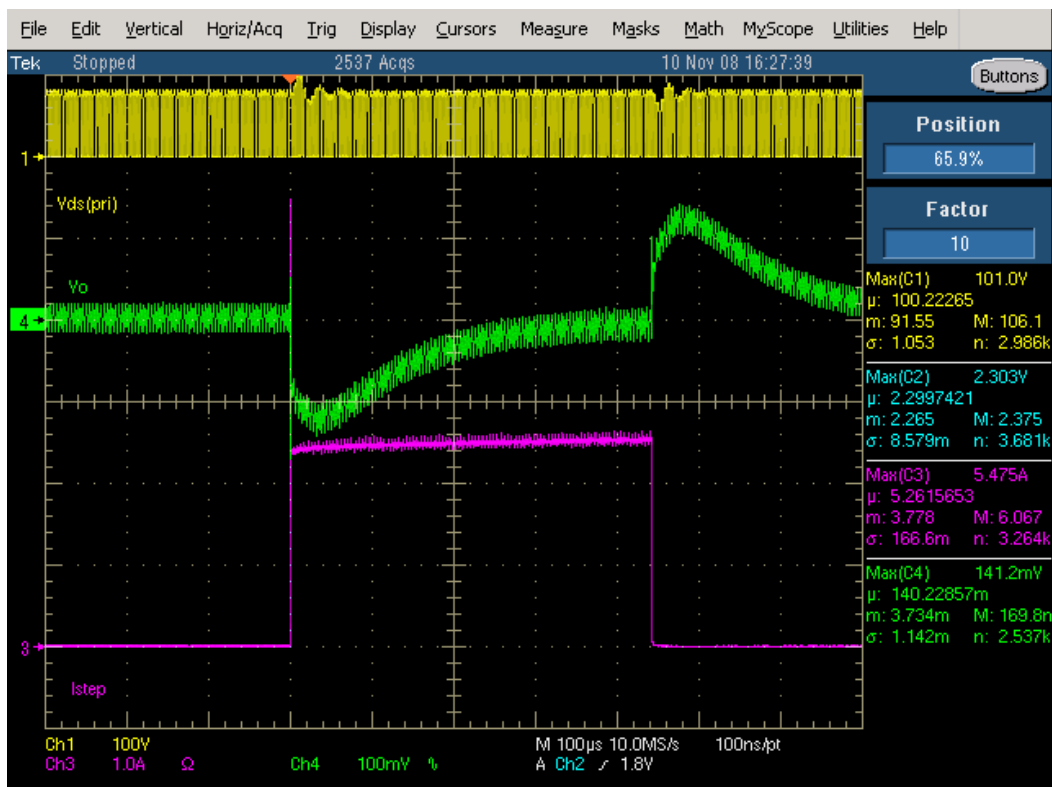

Figure 6. Load Transient Response (48Vport, 2.5A to 5A to 2.5A)

# QUICK START GUIDE FOR DEMONSTRATION CIRCUIT 1351B

## SINGLE OUTPUT, HIGH POWER, HIGH EFFICIENCY POE

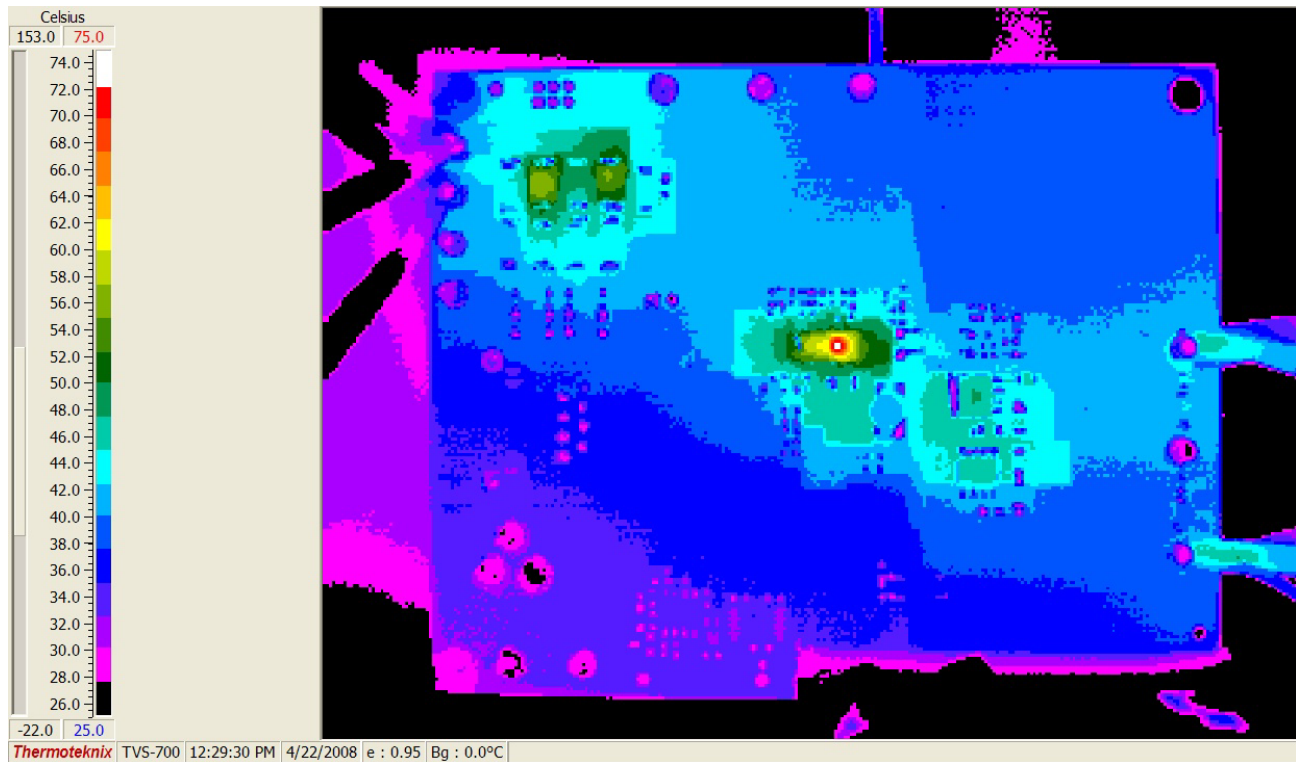

Figure 7. Temp Data (37Vport, 5A, Top)

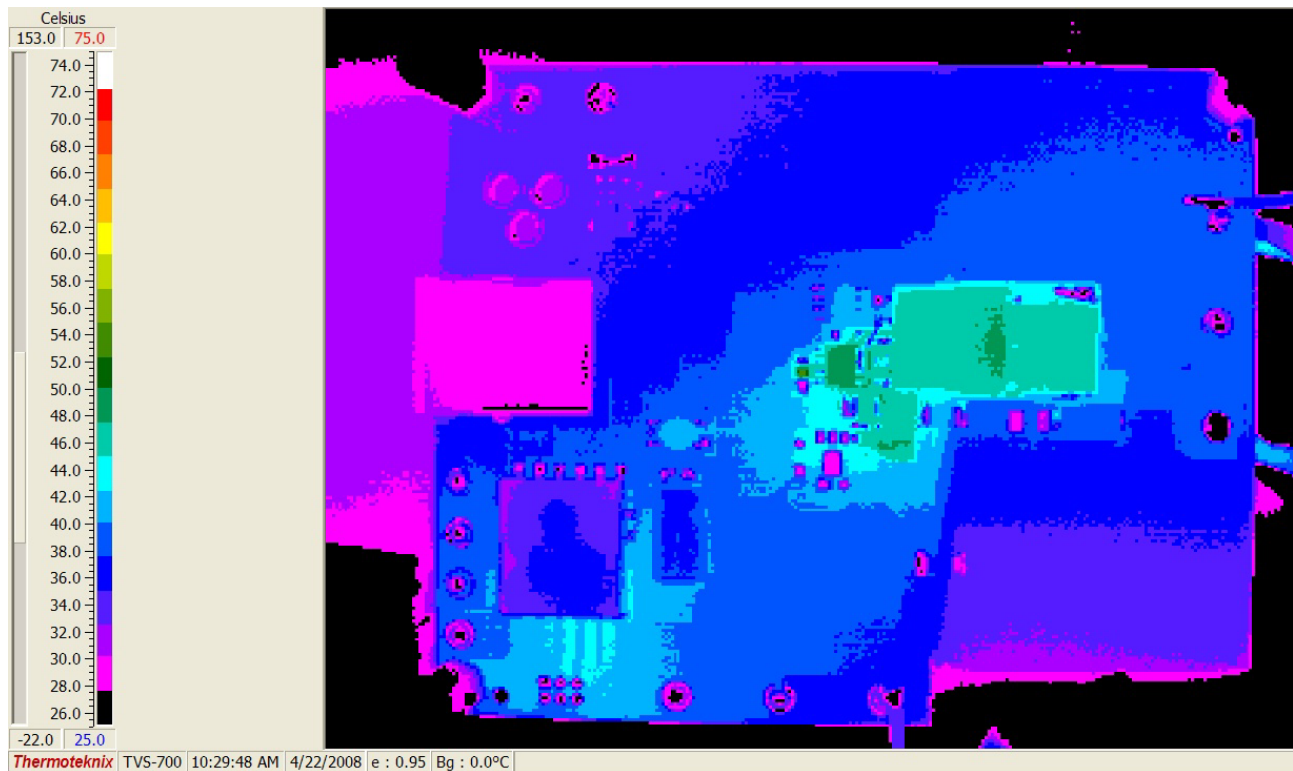

Figure 8. Temp Data (37Vport, 5A, Bottom)

# QUICK START GUIDE FOR DEMONSTRATION CIRCUIT 1351B

## SINGLE OUTPUT, HIGH POWER, HIGH EFFICIENCY POE

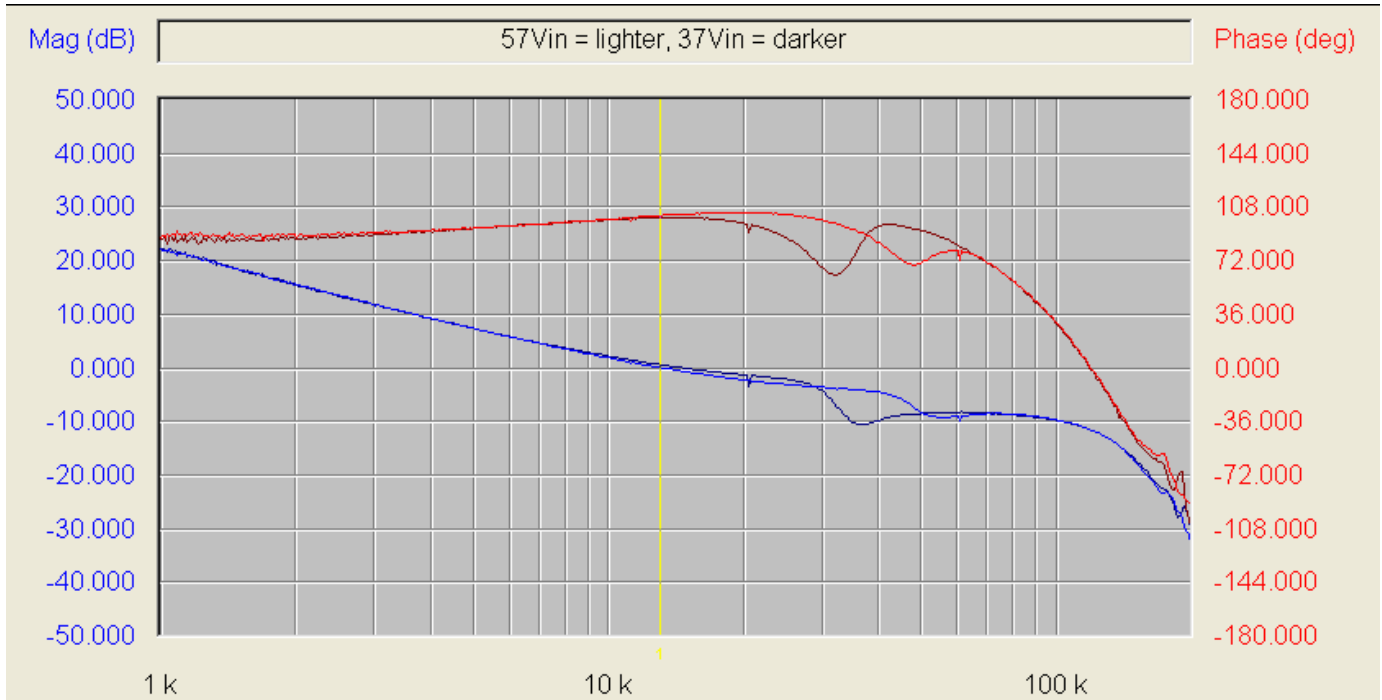

Figure 9. Loop Plot (5A out)

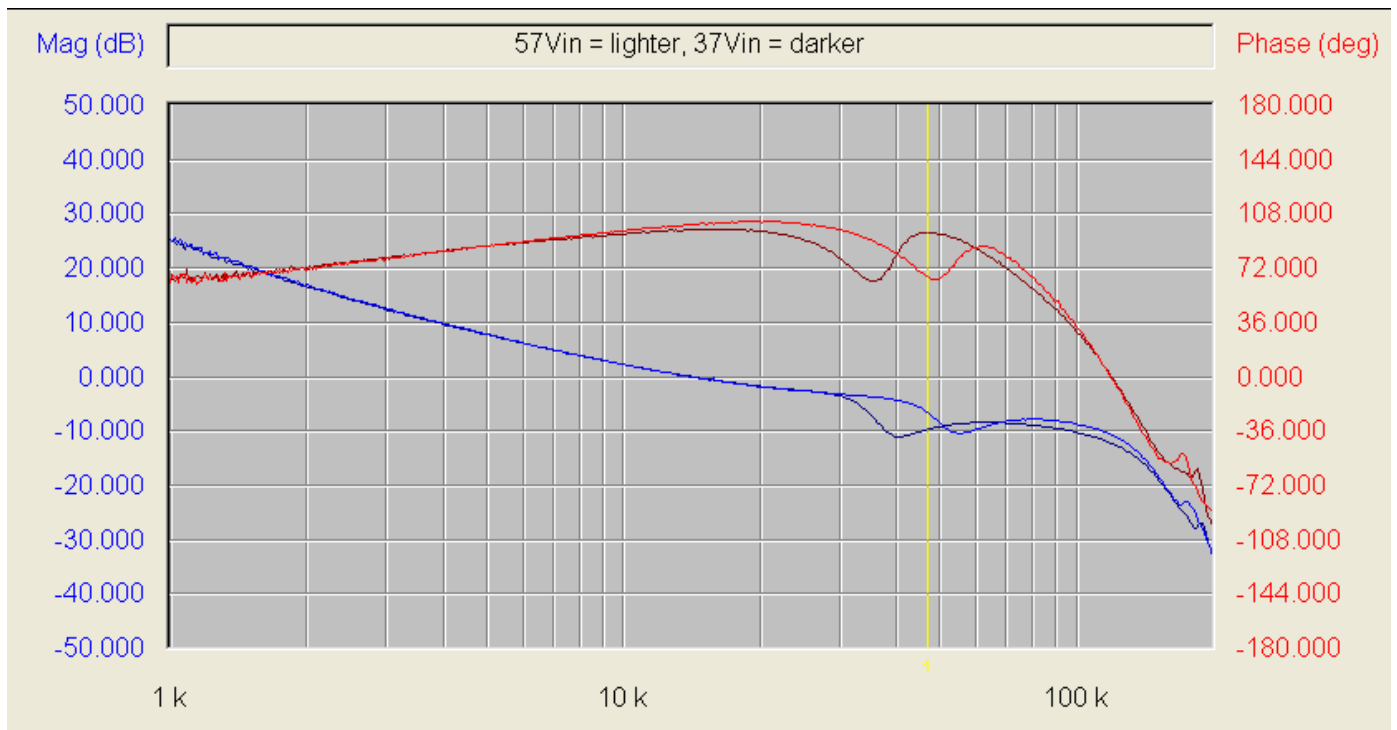

Figure 10. Loop Plot (0A out)



# QUICK START GUIDE FOR DEMONSTRATION CIRCUIT 1351B

## SINGLE OUTPUT, HIGH POWER, HIGH EFFICIENCY POE

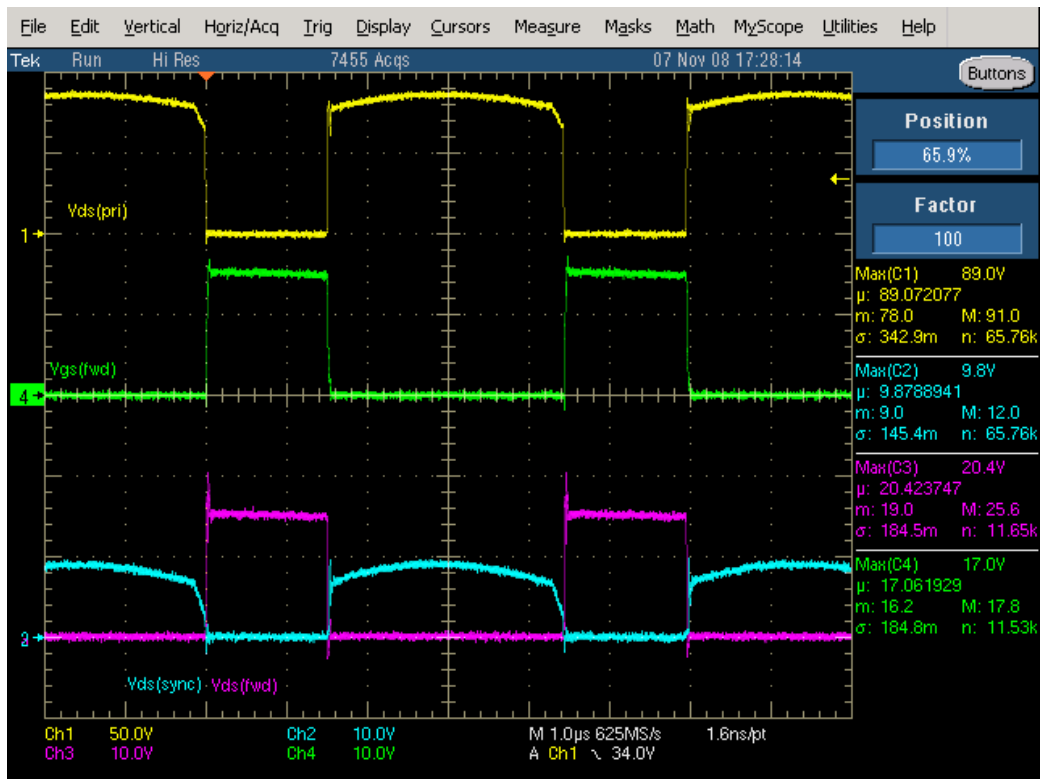

Figure 11. Stresses (57Vport, 5A)

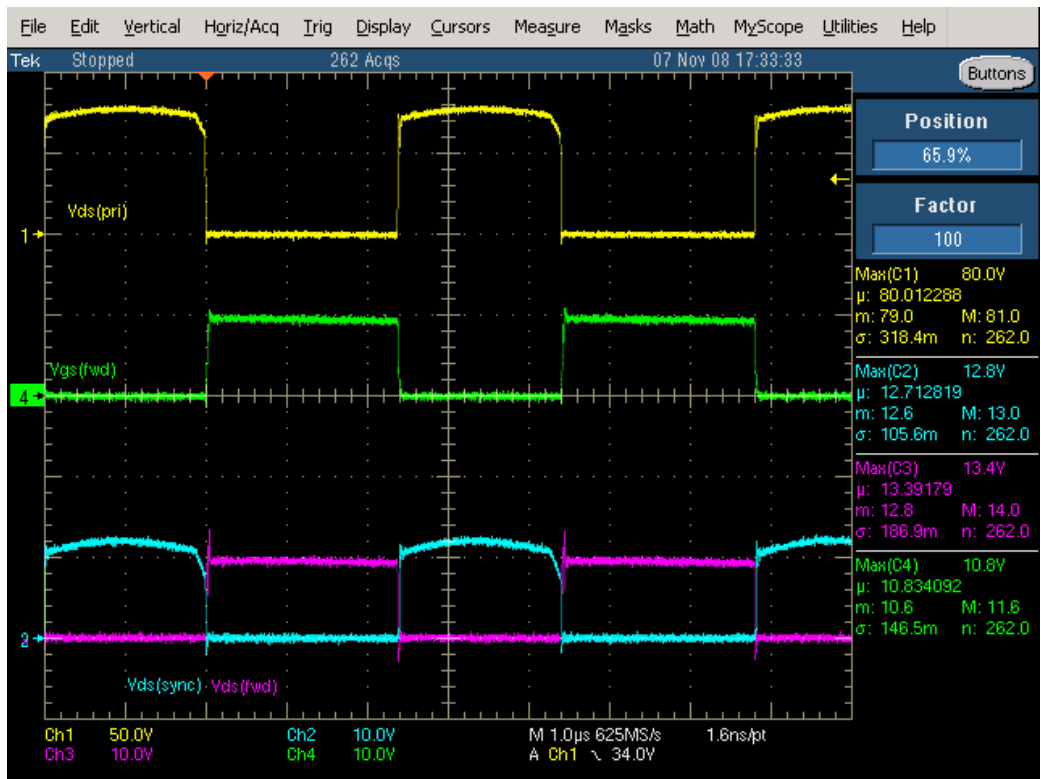
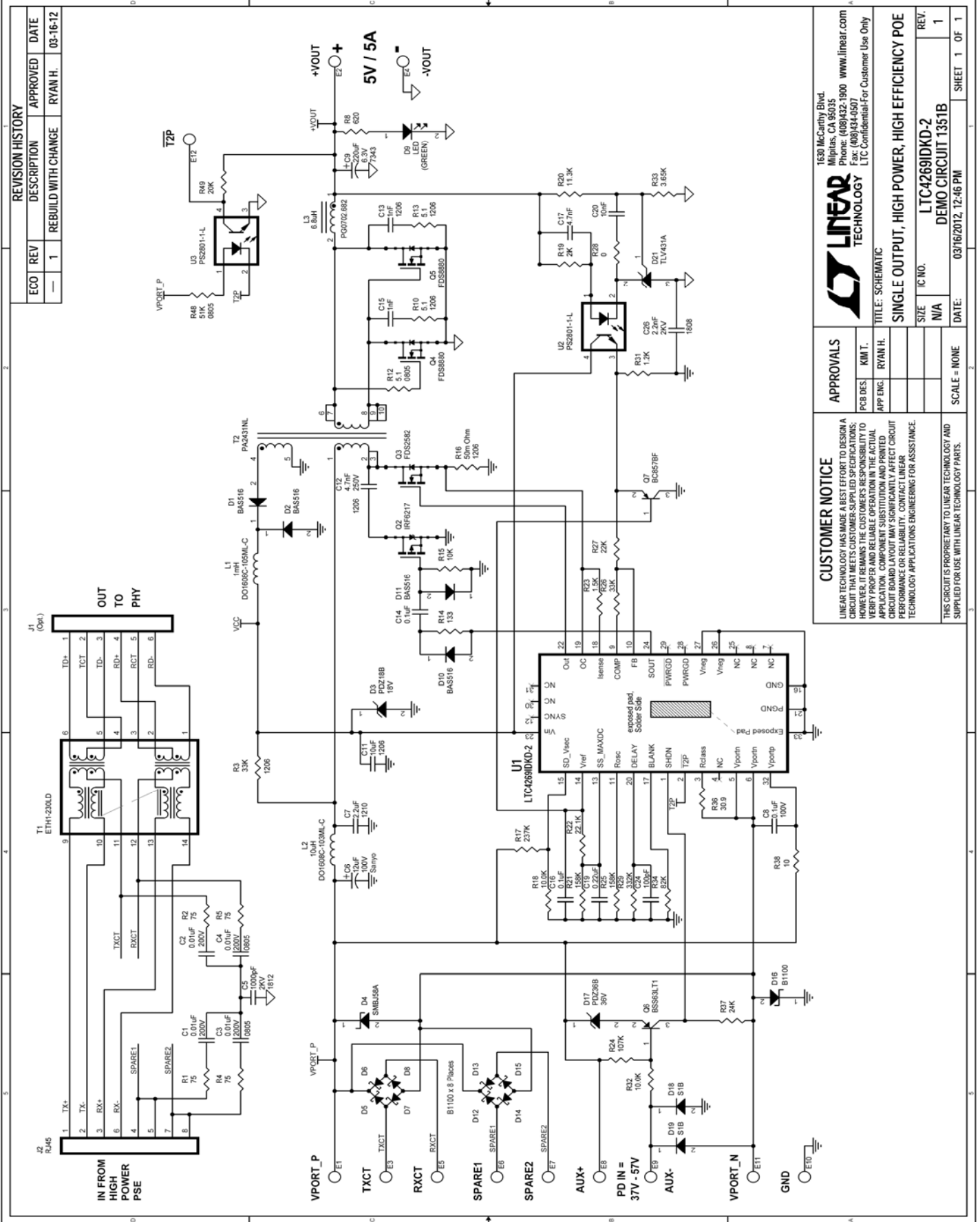

Figure 12. Stresses (37Vport, 5A)



# QUICK START GUIDE FOR DEMONSTRATION CIRCUIT 1351B

## SINGLE OUTPUT, HIGH POWER, HIGH EFFICIENCY POE



REVISION HISTORY				
ECO	REV	DESCRIPTION	APPROVED	DATE
—	1	REBUILD WITH CHANGE	RYAN H.	03-16-12

APPROVALS	
PCB DES.	KIM T.
APP ENG.	RYAN H.

TITLE: SCHEMATIC	
SINGLE OUTPUT, HIGH POWER, HIGH EFFICIENCY POE	
SIZE	IC NO.
N/A	LTC4269DKD-2
DATE:	DEMOCIRCUIT 1351B
03/16/2012, 12:46 PM	
SCALE = NONE	SHEET 1 OF 1

**CUSTOMER NOTICE**

LINEAR TECHNOLOGY HAS MADE A BEST EFFORT TO DESIGN A CIRCUIT BOARD LAYOUT THAT WILL BE SUITABLE FOR USE. HOWEVER, IT REMAINS THE CUSTOMER'S RESPONSIBILITY TO VERIFY PROPER AND RELIABLE OPERATION IN THE ACTUAL APPLICATION. COMPONENT SUBSTITUTION AND PRINTED CIRCUIT BOARD LAYOUT MAY SIGNIFICANTLY AFFECT CIRCUIT PERFORMANCE OR RELIABILITY. CONTACT LINEAR TECHNOLOGY APPLICATIONS ENGINEERING FOR ASSISTANCE.

THIS CIRCUIT IS PROPRIETARY TO LINEAR TECHNOLOGY AND SUPPLIED FOR USE WITH LINEAR TECHNOLOGY PARTS.

1630 McCarthy Blvd.  
Milpitas, CA 95035  
Phone: (408)432-1900 www.linear.com  
Fax: (408)434-0507  
LTC Confidential/For Customer Use Only

**LINEAR TECHNOLOGY**

## X-ON Electronics

Largest Supplier of Electrical and Electronic Components

*Click to view similar products for [Power Management IC Development Tools](#) category:*

*Click to view products by [Analog Devices](#) manufacturer:*

Other Similar products are found below :

[EVAL-ADM1168LQEBZ](#) [EVB-EP5348UI](#) [MIC23451-AAAYFL EV](#) [MIC5281YMME EV](#) [DA9063-EVAL](#) [ADP122-3.3-EVALZ](#) [ADP130-0.8-EVALZ](#) [ADP130-1.2-EVALZ](#) [ADP130-1.5-EVALZ](#) [ADP130-1.8-EVALZ](#) [ADP1714-3.3-EVALZ](#) [ADP1716-2.5-EVALZ](#) [ADP1740-1.5-EVALZ](#) [ADP1752-1.5-EVALZ](#) [ADP1828LC-EVALZ](#) [ADP1870-0.3-EVALZ](#) [ADP1871-0.6-EVALZ](#) [ADP1873-0.6-EVALZ](#) [ADP1874-0.3-EVALZ](#) [ADP1882-1.0-EVALZ](#) [ADP199CB-EVALZ](#) [ADP2102-1.25-EVALZ](#) [ADP2102-1.875EVALZ](#) [ADP2102-1.8-EVALZ](#) [ADP2102-2-EVALZ](#) [ADP2102-3-EVALZ](#) [ADP2102-4-EVALZ](#) [ADP2106-1.8-EVALZ](#) [ADP2147CB-110EVALZ](#) [AS3606-DB](#) [BQ24010EVM](#) [BQ24075TEVM](#) [BQ24155EVM](#) [BQ24157EVM-697](#) [BQ24160EVM-742](#) [BQ24296MEVM-655](#) [BQ25010EVM](#) [BQ3055EVM](#) [NCV891330PD50GEVB](#) [ISLUSBI2CKIT1Z](#) [LM2744EVAL](#) [LM2854EVAL](#) [LM3658SD-AEV/NOPB](#) [LM3658SDEV/NOPB](#) [LM3691TL-1.8EV/NOPB](#) [LM4510SDEV/NOPB](#) [LM5033SD-EVAL](#) [LP38512TS-1.8EV](#) [EVAL-ADM1186-1MBZ](#) [EVAL-ADM1186-2MBZ](#)