

LT3651EUHE-4.2/-4.1 4A High Voltage Li-Ion Battery Charger

DESCRIPTION

Demonstration circuit 1362A-A/1362A-B is a 4A high voltage Li-Ion battery charger featuring the [LT[®]3651EUHE-4.2/LT3651EUHE-4.1](#). The LT3651 is a complete, high power Li-Ion battery charger that can operate over a wide input voltage range. The charger is a constant-current, constant-voltage type with a maximum charge current of 4A that can be externally set. A precondition feature trickle charges a low voltage battery and bad battery detection provides a

signal if the battery doesn't respond to preconditioning. The LT3651EUHE is available in a 36-lead (5mm × 6mm) QFN surface mount package with two exposed thermal pads.

Design files for this circuit board are available at <http://www.linear.com/demo>

LT, LT, LTC, LTM, Linear Technology and the Linear logo are registered trademarks of Linear Technology Corporation. All other trademarks are the property of their respective owners.

PERFORMANCE SUMMARY

Specifications are at $T_A = 25^\circ\text{C}$

Input Voltage Range	6.5V to 32V
V _{OUT}	2.9V to 4.24V (-A)/2.7V to 4.14V (-B)
Output Float Voltage (Constant Voltage Mode)	4.2V (-A)/4.1V (-B)
Output Current Limit I _{LIM}	4A

OPERATING PRINCIPLE

LT3651 is a complete Li-Ion battery charger, addressing wide input voltage (6.5V to 32V) and high charge current (up to 4A). High charging efficiency, as shown in Figure 1, is produced with a constant frequency, average current mode synchronous step-down switcher architecture.

The charger includes the necessary circuitry to allow for programming and control of constant-current, constant-voltage (CC/CV) charging with both current only and timer termination. High charging efficiency is achieved by using a bootstrapped supply for low switch drop on the high side driver and a MOSFET for the low side (synchronous) switch.

Maximum charge current is set with an external sense resistor in series with the inductor and is adjusted through the RNG/SS pin. The total system input current is monitored with an input sense resistor and is used to maintain constant input current by regulating battery charge current. It is adjusted through the I_{LIM} pin.

If the battery voltage is low, charge current automatically reduces to 15% of the programmed current to provide safe battery preconditioning. Once the battery voltage climbs above the battery precondition threshold, the IC automatically increases the maximum charging current to the full programmed value.

OPERATING PRINCIPLE

Charge termination can occur when charge current decreases to one-tenth of the programmed maximum charge current (C/10 termination). Alternately, termination can be timer based through the use of an internal programmable charge cycle control timer. When using the timer termination, charging continues beyond the C/10 level to top off a battery. Charging typically terminates three hours after initiation. When the timer-based scheme is used, bad battery detection is also supported. A system fault is triggered if a battery stays in precondition mode for more than one-eighth of the total charge cycle time.

Once charging is terminated and the LT3651 is not actively charging, the IC automatically enters a low current standby mode in which supply bias currents are reduced to $<85\mu\text{A}$. If the battery voltage drops below 2.5% from the full charge float voltage, the LT3651 engages an automatic charge cycle restart. The IC also automatically restarts a new charge cycle after a bad battery fault once the failed battery is removed and replaced with another battery.

After charging is complete, the input bias current lines connected to the battery are reduced to minimize battery discharge.

The LT3651 contains provisions for a battery temperature monitoring circuit. Battery temperature is monitored by using an NTC thermistor located with the battery. If the

battery temperature moves outside the safe charging range of 0°C to 40°C the charging cycle suspends and signals a fault condition.

The LT3651 contains two digital open-collector outputs, which provide charger status and signal fault conditions. These binary coded pins signal battery charging, standby or shutdown modes, battery temperature faults and bad battery faults.

A precision undervoltage lockout is possible by using a resistor divider on the shutdown pin (SHDN). The input supply current is $17\mu\text{A}$ when the IC is in shutdown.

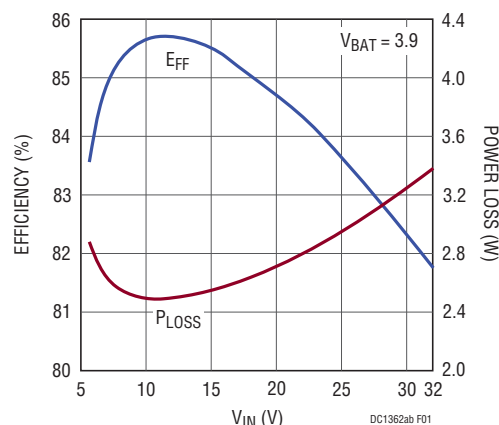

Figure 1. Efficiency and Power Loss vs V_{IN}

QUICK START PROCEDURE

Demonstration circuit 1362A-A/1362A-B is easy to set up to evaluate the performance of the LT3651EUHE-4.2/LT3651EUHE-4.1.

Using short twisted pair leads for any power connections, with all loads and power supplies off, refer to Figure 2 for the proper measurement and equipment setup.

Follow the procedure below:

1. Jumper and power supply setting:

JP1 = RUN	PS1 = OFF
JP2 = C/10	PS2 = OFF

2. Turn on PS2 and slowly increase the voltage to 2.7V while monitoring the current into the BAT pin. If the current is less than 5mA, turn on PS1. Increase the voltage on PS1 to 4V while monitoring the input current. If the current is less than 5mA, increase PS1 to 12V.
3. Verify that the battery charging current, I_{BAT} is between 400mA and 600mA. The CHR_G LED and ACPR LED should be on and the FAULT LED should be off.

QUICK START PROCEDURE

4. Increase PS2 until VBAT is 3.6V. Verify the input current IIN is between 1.4A and 1.7A, the battery current IBAT is between 3.75A and 4.45A and that the CHRГ LED and ACPR LED are on.
5. Increase PS2 until VBAT is 4.25V. Verify the battery charging current IBAT is less than 5mA and that the CHRГ LED and ACPR LED are off.
6. Decrease PS2 until VBAT is 3.9V. Verify the battery current IBAT is between 3.75A and 4.45A that the CHRГ LED and ACPR LED are on.
7. Decrease PS2 until VBAT is 3.6V. Connect a 10k resistor from the RNG/SS pin to ground. Verify the charging current IBAT is between 1.7A and 2.0A. Verify the voltage VNTC on the NTC turret is between 1.6V and 1.9V and the voltage VRNG on the RNG/SS turret is between 450mV and 700mV. Remove the 10k resistor from the RNG/SS pin to ground
8. Set JP1 to SHDN. Verify the charging current IBAT is less than 5mA and that the FAULT LED, CHRГ LED and ACPR LED are off.
9. Set JP1 to RUN. Connect a jumper from the NTC pin to ground. Verify the charging current IBAT is less than 5mA and that the FAULT LED, CHRГ LED and ACPR LED are on.
10. Remove the jumper from NTC to ground. Verify the charging current IBAT is between 3.75A and 4.45A and that the FAULT LED is off and the CHRГ LED and ACPR LED are on.
11. Turn on LOAD1 and set to 1A. Verify the voltage VSYSTEM on the system voltage turret is approximately equal to VIN.
12. Turn off PS1, PS2 and LOAD1.

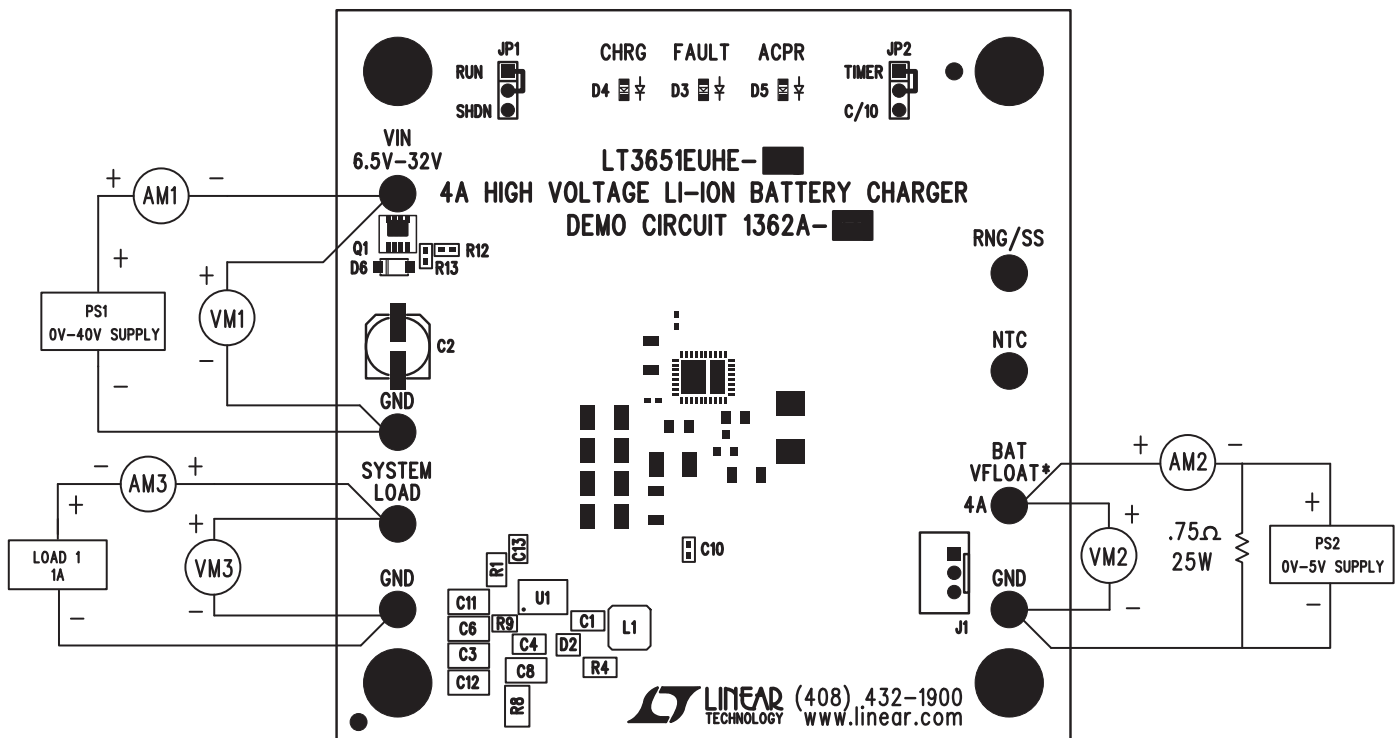

NOTE: ALL CONNECTIONS FROM EQUIPMENT SHOULD BE KELVIN CONNECTED DIRECTLY TO THE BOARD PINS WHICH THEY ARE CONNECTED TO ON THIS DIAGRAM AND ANY INPUT, OR OUTPUT, LEADS SHOULD BE TWISTED PAIR.

DC1362ab F02

Figure 2. Proper Measurement Equipment Setup

DEMO MANUAL DC1362A-A/-B

PARTS LIST

ITEM	QTY	REFERENCE	PART DESCRIPTION	MANUFACTURER/PART NUMBER
Required Circuit Components				
1	1	C1	CAP, X7R, 1 μ F, 50V, 10%, 0805	MURATA, GRM21BR71H105KA12L
2	4	C3, C6, C11, C12	CAP, X7S, 10 μ F, 50V, 20%, 1210	TDK, C3225X7S1H106M
3	1	C4	CAP, X7R, 10 μ F, 10V, 10%, 0805	MURATA, GRM21BR71A106KE51L
4	3	C5, C7, C13	CAP, X5R, 0.68 μ F, 10V, 10%, 0402	MURATA, GRM155R61A684KE15D
5	1	C8	CAP, X5R, 100 μ F, 6.3V, 20%, 1210	TAIYO YUDEN, LMK325BJ107MM-T
6	1	D2	SMD, SCHOTTKY DIODE, SOT-23	CENTRAL SEMI, CMPSH1-4 TR
7	1	D6	DIODE, ZENER, 10V SOD-123	CENTRAL SEMI, CMHZ4697
8	1	L1	POWER INDUCTOR 3.3 μ H 20% 8.0A, 9m Ω 7mm x 7mm	WURTH, 744314330
9	1	Q1	MOSFET, PCHANNEL, 40V, 25m Ω 1212-8	VISHAY, Si7611DN
10	1	R1	RES, CHIP, 0.015 Ω , 1/2W, 1%, 1206	IRC, LRC-LR1206LF-01-R015-F
11	1	R4	RES, CHIP, 0.024 Ω , 1/2W, 1%, 1206	IRC, LRC-LR1206LF-01-R024-F
12	2	R5, R12	RES, CHIP, 10k, 1/16W, 1%, 0402	VISHAY, CRCW040210K0FKED
13	1	R7	RES, CHIP, 44.2k, 1/16W, 1%, 0402	VISHAY, CRCW040244K2FKED
14	1	R8	RES, CHIP, 0.05 Ω , 1/2W, 1%, 1206	IRC, LRC-LR1206LF-01-R050-F
15	1	R9	RES, CHIP, 147k, 1/16W, 1%, 0402	VISHAY, CRCW0402147KFKED
16	1	R13	RES, CHIP, 100k, 1/16W, 1%, 0402	VISHAY, CRCW0402100KFKED
17	1	U1 (-A VERSION) U1 (-B VERSION)	4A HIGH VOLTAGE LI-ION BATTERY CHARGER	LINEAR TECHNOLOGY, LT3651EUHE-4.2 LINEAR TECHNOLOGY, LT3651EUHE-4.1
Optional Electrical Components				
1	1	C2	CAP, SMT, 22 μ F, 50V 20%	SUNCON, 50CE22BS
2	2	C9, C10	CAP, CHIP, X7R, 0.022 μ F, \pm 10%, 16V, 0402	AVX, 0402YC223KAT2A
3	0	D1	SMD, SCHOTTKY, 5A, 40V	DIODES INC, PDS540-13
4	1	D3	LED, RED	PANASONIC, LNJ208R8ARA
5	2	D4, D5	LED, GREEN	LITE-ON, LTST-C190KGKT
6	0	J1	HEADER, 3 PINS	HIROSE ELECTRIC, DF3A-3P-2DSA
7	3	R2, R3, R10	RES, CHIP, 5.1k, 1/4W, 5%, 1206	VISHAY, CRCW12065K10JNED
8	0	R6, R11	RES, CHIP, 20k, 1/16W, 1%, 0402	VISHAY, CRCW040220K0FKED
Hardware for Demo Circuit				
1	8	E1 TO E8	TESTPOINT, TURRET 0.095"	MILL-MAX, 2501-2-00-80-00-00-07-0
2	2	JP1, JP2	2MM SINGLE ROW HEADER 3 PIN	SAMTEC, TMM-103-02-L-S
3	2	JP1, JP2	SHUNT	SAMTEC, 2SN-BK-G
4	4	MH1 TO MH4	STAND-OFF, NYLON 0.375" TALL (SNAP ON)	KEYSTONE, 8832 (SNAP ON)

SCHEMATIC DIAGRAM

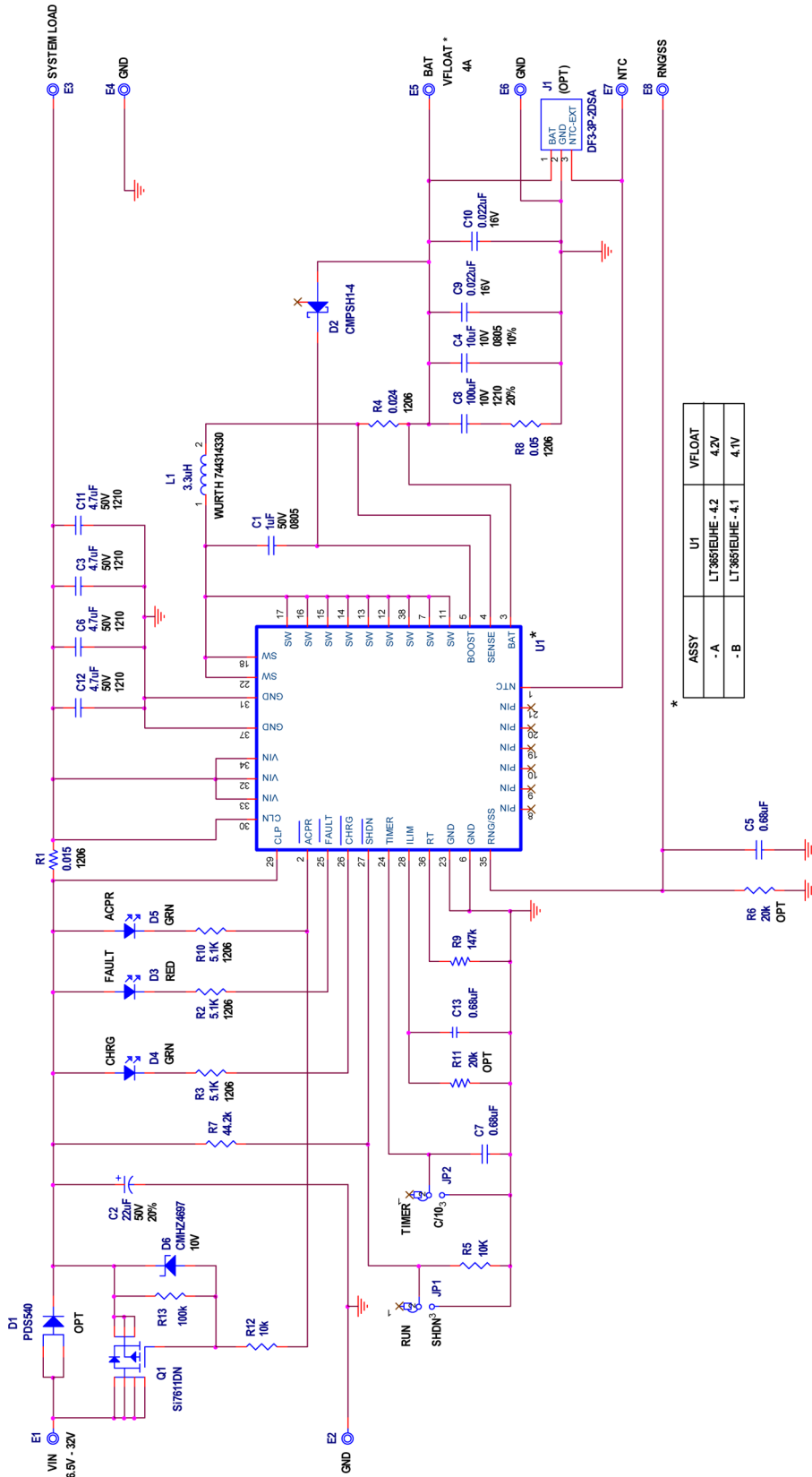

ASSY	U1	VFLOAT
-A	LT365FEUHE-4.2	4.2V
-B	LT365FEUHE-4.1	4.1V

DEMO MANUAL DC1362A-A/-B

DEMONSTRATION BOARD IMPORTANT NOTICE

Linear Technology Corporation (LTC) provides the enclosed product(s) under the following **AS IS** conditions:

This demonstration board (DEMO BOARD) kit being sold or provided by Linear Technology is intended for use for **ENGINEERING DEVELOPMENT OR EVALUATION PURPOSES ONLY** and is not provided by LTC for commercial use. As such, the DEMO BOARD herein may not be complete in terms of required design-, marketing-, and/or manufacturing-related protective considerations, including but not limited to product safety measures typically found in finished commercial goods. As a prototype, this product does not fall within the scope of the European Union directive on electromagnetic compatibility and therefore may or may not meet the technical requirements of the directive, or other regulations.

If this evaluation kit does not meet the specifications recited in the DEMO BOARD manual the kit may be returned within 30 days from the date of delivery for a full refund. THE FOREGOING WARRANTY IS THE EXCLUSIVE WARRANTY MADE BY THE SELLER TO BUYER AND IS IN LIEU OF ALL OTHER WARRANTIES, EXPRESSED, IMPLIED, OR STATUTORY, INCLUDING ANY WARRANTY OF MERCHANTABILITY OR FITNESS FOR ANY PARTICULAR PURPOSE. EXCEPT TO THE EXTENT OF THIS INDEMNITY, NEITHER PARTY SHALL BE LIABLE TO THE OTHER FOR ANY INDIRECT, SPECIAL, INCIDENTAL, OR CONSEQUENTIAL DAMAGES.

The user assumes all responsibility and liability for proper and safe handling of the goods. Further, the user releases LTC from all claims arising from the handling or use of the goods. Due to the open construction of the product, it is the user's responsibility to take any and all appropriate precautions with regard to electrostatic discharge. Also be aware that the products herein may not be regulatory compliant or agency certified (FCC, UL, CE, etc.).

No License is granted under any patent right or other intellectual property whatsoever. **LTC assumes no liability for applications assistance, customer product design, software performance, or infringement of patents or any other intellectual property rights of any kind.**

LTC currently services a variety of customers for products around the world, and therefore this transaction **is not exclusive**.

Please read the DEMO BOARD manual prior to handling the product. Persons handling this product must have electronics training and observe good laboratory practice standards. **Common sense is encouraged.**

This notice contains important safety information about temperatures and voltages. For further safety concerns, please contact a LTC application engineer.

Mailing Address:

Linear Technology
1630 McCarthy Blvd.
Milpitas, CA 95035

Copyright © 2004, Linear Technology Corporation

X-ON Electronics

Largest Supplier of Electrical and Electronic Components

Click to view similar products for [Power Management IC Development Tools](#) category:

Click to view products by [Analog Devices](#) manufacturer:

Other Similar products are found below :

[EVAL-ADM1168LQEBZ](#) [EVB-EP5348UI](#) [MIC23451-AAAYFL EV](#) [MIC5281YMME EV](#) [DA9063-EVAL](#) [ADP122-3.3-EVALZ](#) [ADP130-0.8-EVALZ](#) [ADP130-1.2-EVALZ](#) [ADP130-1.5-EVALZ](#) [ADP130-1.8-EVALZ](#) [ADP1714-3.3-EVALZ](#) [ADP1716-2.5-EVALZ](#) [ADP1740-1.5-EVALZ](#) [ADP1752-1.5-EVALZ](#) [ADP1828LC-EVALZ](#) [ADP1870-0.3-EVALZ](#) [ADP1871-0.6-EVALZ](#) [ADP1873-0.6-EVALZ](#) [ADP1874-0.3-EVALZ](#) [ADP1882-1.0-EVALZ](#) [ADP199CB-EVALZ](#) [ADP2102-1.25-EVALZ](#) [ADP2102-1.875EVALZ](#) [ADP2102-1.8-EVALZ](#) [ADP2102-2-EVALZ](#) [ADP2102-3-EVALZ](#) [ADP2102-4-EVALZ](#) [ADP2106-1.8-EVALZ](#) [ADP2147CB-110EVALZ](#) [AS3606-DB](#) [BQ24010EVM](#) [BQ24075TEVM](#) [BQ24155EVM](#) [BQ24157EVM-697](#) [BQ24160EVM-742](#) [BQ24296MEVM-655](#) [BQ25010EVM](#) [BQ3055EVM](#) [NCV891330PD50GEVB](#) [ISLUSBI2CKIT1Z](#) [LM2744EVAL](#) [LM2854EVAL](#) [LM3658SD-AEV/NOPB](#) [LM3658SDEV/NOPB](#) [LM3691TL-1.8EV/NOPB](#) [LM4510SDEV/NOPB](#) [LM5033SD-EVAL](#) [LP38512TS-1.8EV](#) [EVAL-ADM1186-1MBZ](#) [EVAL-ADM1186-2MBZ](#)