

Synchronous 1A Buck-Boost DC/DC Converter and Dual 600mA Buck DC/DC Converters

DESCRIPTION

Demonstration circuit 1389A is high efficiency triple output DC/DC power supply featuring the LTC3521. The IC includes a 4-switch synchronous Buck-Boost DC/DC converter with 1A switch ratings and two synchronous 600mA Buck converters. The board will accept an input voltage between 2.4V and 5V, and provide fixed output voltages of 3.3V @800mA for the Buck-Boost converter and 1.2V & 1.8V @600mA for the Buck converters.

The board includes jumpers for shutdown for each converter, one jumper for PWM or BURST operation and terminals to monitor each converter's Power Good output signal. Other features are; 1 μ A shutdown current, integrated soft start, thermal and over current protection, under voltage lockout, 100% duty cycle for the Buck converter and a 1MHz switching frequency that allows small L and C components to be used.

With BURST mode selected, the buck converters operate in BURST mode at low load current and automatically

switch to PWM mode at higher loads. The Buck-Boost converter will also operate in burst mode but the available load current is reduced considerably, to approximately 50mA. No load BURST mode quiescent current is approximately 50 μ A. When all three converters are shutdown, the quiescent current drops to less than 1 μ A.

The Power Good output terminals pull low if the output voltage is 8% or more below the regulation voltage.

The LTC3521 datasheet gives a complete description of the part, operation and application information. The datasheet must be read in conjunction with this quick start guide.

Design files for this circuit board are available. Call the LTC factory.

 , LTC and LT are registered trademarks of Linear Technology Corporation. ThinSOT and PowerPath are trademarks of Linear Technology Corporation.

Performance Summary ($T_A = 25^{\circ}\text{C}$)

PARAMETER	CONDITION	VALUE
Input Voltage Range		2.4V to 5V
Buck-Boost Output Voltage (Vout 1)	Vin = 2.4V, Vout Load = 100mA	3.3V +/- 2.5%
Buck Output Voltage (Vout 2)	Vin = 2.4V, Vout Load = 100mA	1.2V +/- 2.5%
Buck Output Voltage (Vout 3)	Vin = 2.4V, Vout Load = 100mA	1.8V +/- 2.5%
Maximum Output Current (Buck-Boost)	Vin = 2.4V, PWM mode	800mA
Maximum Output Current (Buck)	Vin = 2.4V	600mA
Input Supply Current	All Converters Shutdown, Vin = 2.4V	<1 μ A
Input Supply Current (no load)	All Converters Enabled, BURST Mode, Vin = 2.4V, No Load	50 μ A, typ.
Input Supply Current (no load)	All Converters Enabled, PWM Mode, Vin = 2.4V, No Load	8.5mA, typ.

Table 1. Circuit Specifications

QUICK START PROCEDURE

This Demonstration circuit 1389A can be evaluated using the setup shown in Figure 1.

1. Place all Shutdown jumpers in the ON position and the MODE jumper to the PWM position.

QUICK START GUIDE FOR DEMONSTRATION CIRCUIT 1389A

- With AC power off, connect the input power supply to Vin and GND.
- Connect voltmeters to Vin and ground terminals and each Vout and Ground terminals.
- With the input voltage turned down, switch on the input power supply and raise the input voltage to 1.8V.
- Verify that each output voltage meets the values as shown in Table 1.
- Increase the input voltage to 2.5V and connect suitable load resistors between each output and ground.
- Verify each output voltage. If an output is low, temporarily disconnect the load to make sure that the load current is not set too high. Also, monitor the input voltage at the board terminals to verify that the input voltage has not dropped due to the increased input current. Note: The Buck-Boost converter output current is limited to approximately 50mA if the Mode jumper is set for BURST.
- When measuring the input or output voltage ripple, care must be taken to avoid a long ground lead on the oscilloscope probe. Measure the input or output voltage ripple by touching the probe tip directly across the Vin or Vout and GND terminals. See Figure 2 for proper scope probe technique.
- The Power Good terminals can be monitored with a voltmeter or an oscilloscope. The Power Good outputs pull low if the output voltage is 8% or more below the regulation voltage, otherwise they are pulled up to their respective output voltage through a 1MΩ pull-up resistor.
- To measure no load input current, connect a mA/μA meter in series with the input supply, adjust for 2.4V and read meter. Both BURST and PWM quiescent current can be verified by moving JP1 to the appropriate position.

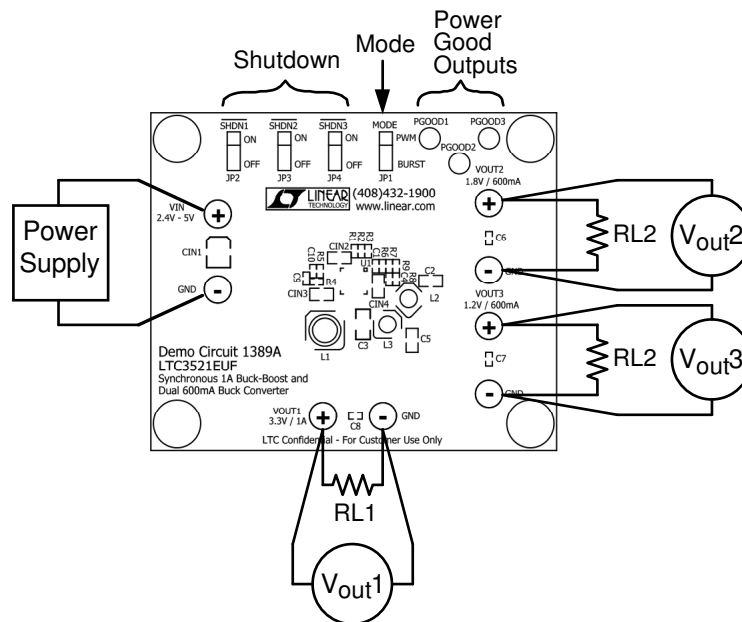

Figure 1. Proper Measurement Equipment Setup

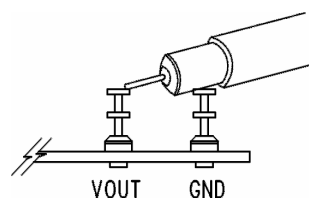
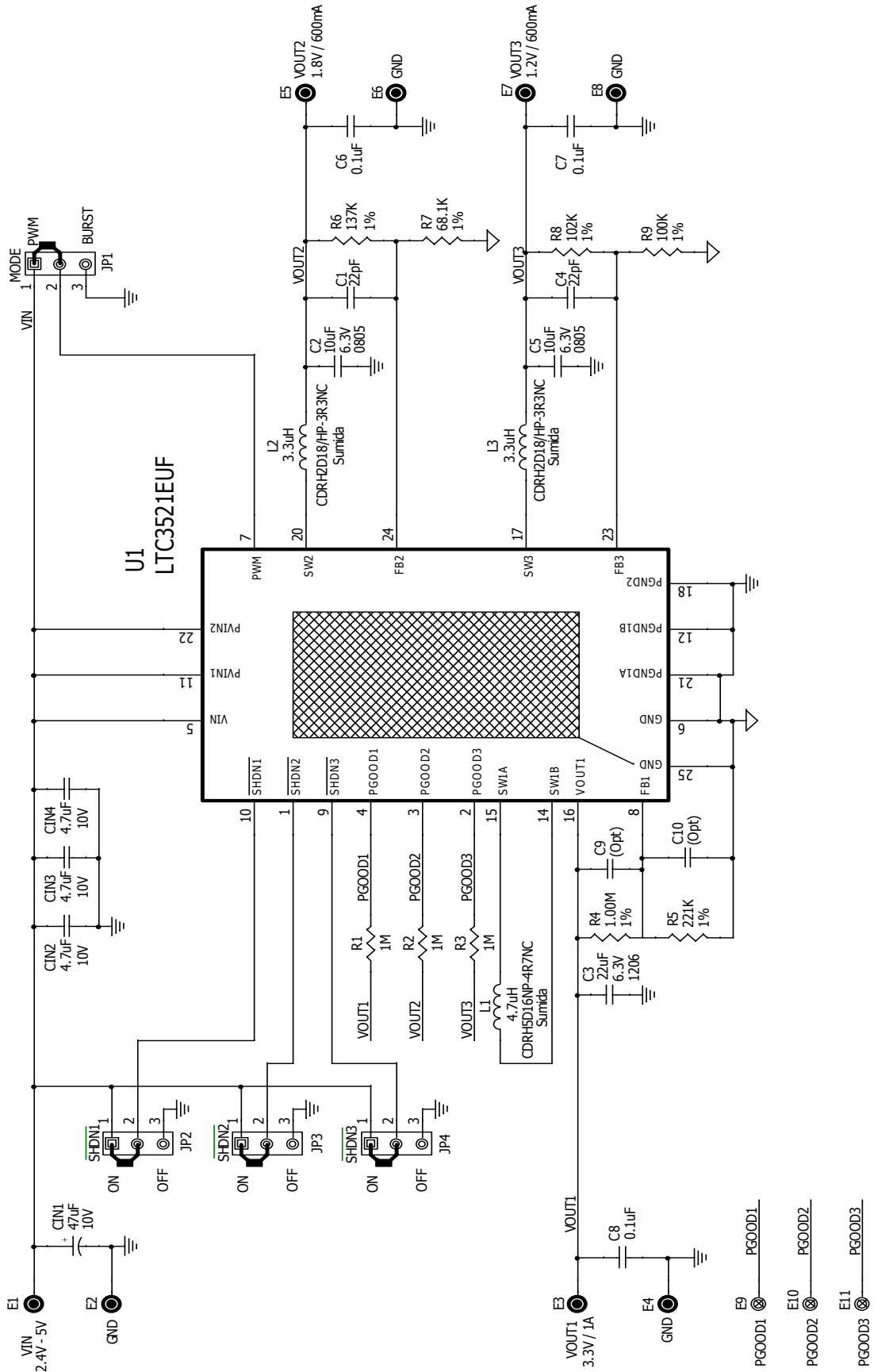

Figure 2. Measuring Input or Output Voltage Ripple

QUICK START GUIDE FOR DEMONSTRATION CIRCUIT 1389A



X-ON Electronics

Largest Supplier of Electrical and Electronic Components

Click to view similar products for [Power Management IC Development Tools](#) category:

Click to view products by [Analog Devices](#) manufacturer:

Other Similar products are found below :

[EVAL-ADM1168LQEBZ](#) [EVB-EP5348UI](#) [MIC23451-AAAYFL EV](#) [MIC5281YMME EV](#) [DA9063-EVAL](#) [ADP122-3.3-EVALZ](#) [ADP130-0.8-EVALZ](#) [ADP130-1.2-EVALZ](#) [ADP130-1.5-EVALZ](#) [ADP130-1.8-EVALZ](#) [ADP1714-3.3-EVALZ](#) [ADP1716-2.5-EVALZ](#) [ADP1740-1.5-EVALZ](#) [ADP1752-1.5-EVALZ](#) [ADP1828LC-EVALZ](#) [ADP1870-0.3-EVALZ](#) [ADP1871-0.6-EVALZ](#) [ADP1873-0.6-EVALZ](#) [ADP1874-0.3-EVALZ](#) [ADP1882-1.0-EVALZ](#) [ADP199CB-EVALZ](#) [ADP2102-1.25-EVALZ](#) [ADP2102-1.875EVALZ](#) [ADP2102-1.8-EVALZ](#) [ADP2102-2-EVALZ](#) [ADP2102-3-EVALZ](#) [ADP2102-4-EVALZ](#) [ADP2106-1.8-EVALZ](#) [ADP2147CB-110EVALZ](#) [AS3606-DB](#) [BQ24010EVM](#) [BQ24075TEVM](#) [BQ24155EVM](#) [BQ24157EVM-697](#) [BQ24160EVM-742](#) [BQ24296MEVM-655](#) [BQ25010EVM](#) [BQ3055EVM](#) [NCV891330PD50GEVB](#) [ISLUSBI2CKIT1Z](#) [LM2744EVAL](#) [LM2854EVAL](#) [LM3658SD-AEV/NOPB](#) [LM3658SDEV/NOPB](#) [LM3691TL-1.8EV/NOPB](#) [LM4510SDEV/NOPB](#) [LM5033SD-EVAL](#) [LP38512TS-1.8EV](#) [EVAL-ADM1186-1MBZ](#) [EVAL-ADM1186-2MBZ](#)