

LT6230, LT6230-10, LTC6240
 Low Noise +/-5V Transimpedance Amplifier

DESCRIPTION

Demonstration Circuit 1417 is a Low Noise Transimpedance Amplifier. It utilizes the low voltage noise LT6230 and LT6230-10 opamps, and the low current noise LTC6240 opamp, along with the discrete NXP JFET BF862, allowing the user to take advantage of each component's particular optimization. These components are arranged with jumpers allowing various composite con-

figurations. A socketed photodiode, OSRAM SFH213, is also provided.

Design files for this circuit board are available. Call the LTC factory.

LT, are registered trademarks of Linear Technology Corporation. Other product names may be trademarks of the companies that manufacture the products.

PERFORMANCE SUMMARY

 Specifications are typical at $T_A = 25^\circ\text{C}$, $V_S = \pm 5\text{V}$

SYMBOL	PARAMETER	CONDITIONS, COMMENTS	TYP	UNITS
V_S	Supply Voltage	Nominal	+/-5V	V
	Supply Voltage Range	Source Follower	+/-2V to +/-6V	V
	Supply Voltage	JFET in Gain	+/-3V to +/-6V	V
A_Z	TIA Gain	R1 + R2	1M	Ω
V_{OS}	Input Offset Voltage	LTC6240 ($V_{OS} + I_{BIAS} * 10M$)	70	μV
dV_{OS}/dT	Input Offset Voltage Drift	LTC6240 ($dV_{OS}/dT + dI_{BIAS}/dT * 10M$)	2	$\mu\text{V}/^\circ\text{C}$
I_{BIAS}	Input Bias Current	LTC6240 + BF862	3.5	pA
e_n	Input Voltage Noise Density	f=100kHz, JFET in gain configuration	1	$\text{nV}/\sqrt{\text{Hz}}$
e_n	Input Voltage Noise Density	f=100kHz, Source Follower configuration	1.5	$\text{nV}/\sqrt{\text{Hz}}$
C_{in}	Input Capacitance	f=10kHz, Source Follower configuration	2	pF
C_{in}	Input Capacitance	f=10kHz, JFET in gain configuration	8	pF
GBW	Gain Bandwidth Product	JP8 at 1,2 (LT6230)	70	MHz
GBW	Gain Bandwidth Product	JP8 at 2,3 (LT6230-10)	190	MHz
BW	-3dB Bandwidth, SFH213 and 1M Ω Gain	Source Follower, JP8 at 1,2 (LT6230)	2.6	MHz
		Source Follower, JP8 at 2,3 (LT6230-10) (add 24pF in parallel with photodiode)	3.3	MHz
V_{OUT}	Output Voltage Swing	Cathode input, Integrator in	0 to 4.9V	V
V_{OUT}	Output Voltage Swing	Cathode input, Integrator out	-0.4 to 4.9	V
V_{OUT}	Output Voltage Swing	Anode input, Integrator in	0 to -4.9V	V
V_{OUT}	Output Voltage Swing	Anode input, Integrator out	-0.4 to -4.9V	V
I_{CC}	Supply Current	$V_S = \pm 5\text{V}$	12	mA

OPERATING PRINCIPLES

Composite amplifiers using single JFET inputs can be classified into two groups: common drain (or “source follower”) and common source (or “JFET in gain”). The standard jumper configuration of this board, as shipped and as indicated on the silkscreen, has the JFET as a source follower.

Another classification is DC accuracy. The LTC6240 has been provided on board as an integrator to provide DC accuracy, overriding the high 400mV or so V_{gs} of the JFET. The standard jumper configuration is “Integrator

In”, so the TIA will be DC accurate to within the V_{os} of the LTC6240 (250uV max, plus 10uV due to I_{bias}). With the integrator removed from the circuit, the DC error rises to 400mV or so.

The feedback resistor, which sets the TIA gain, is formed by R1 and R2 in series and is set to 1M Ω . So the output responds at 1V per micropamp of photocurrent. R1 and R2 can be changed to achieve other transimpedance gains.

QUICK START PROCEDURE

Demonstration circuit 1417 is shipped with the jumpers set for Source Follower operation with the Integrator In. If the jumpers have been changed, restore them to the positions shown in the schematic. Refer to Figure 1 for proper measurement equipment setup and follow the procedure below:

1. With power off, connect the +5V, -5V, and Com leads from the power supply to the V+, V-, and Gnd terminals of the demo circuit, as shown in Figure 1.
2. With power off, connect the V_{OUT} of the demo circuit to an oscilloscope or DMM. You can use either the gold SMA connector or the turrets provided on board, or both. Set a high range such as 2V/DIV on the oscilloscope, or Vdc on the DMM.
3. Turn on the power supply.

4. You should now be able to wave your hand over the clear Photodiode provided on the board (upper left of Figure 1) and see the effect in both DC signal and noise. With the photodiode in darkness, or removed from its socket, the output should sit near ground.
5. You can now connect an optical source to excite the photodiode in a more controlled manner. The easiest way is to drive an LED directly from a function generator, with the function generator’s internal 50 Ohm source impedance as a current limiter. Any standard color or IR LED can be used, as the Photodiode provided has a wide sensitivity. Be careful not to overdrive sensitive devices such as small lasers.
6. You can now decide whether to play with other configurations (LT6230-10, or JFET in gain, Integrator Out, etc), or to replace the provided Photodiode with the one you intend to use.

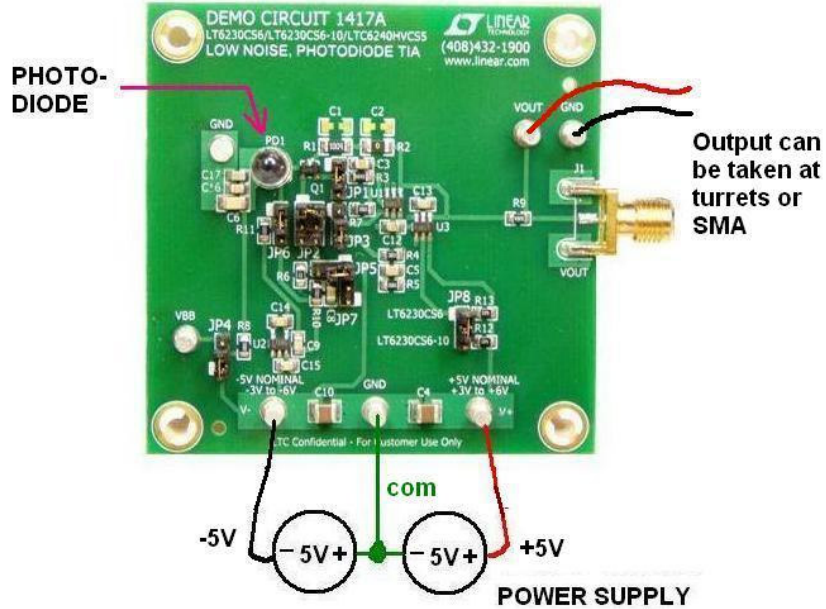

Figure 1. Proper Supply Connections. Board is shown configured for Source Follower with Integrator In. All jumpers (except JP7) have the shunt in position “1”. (JP7 is open.) To replace the LT6230 with the faster LT6230-10, move JP8 down.

Table 1: Jumper settings for various configurations. Refer to Figures 2 and 3 for qualitative descriptions of the configurations, and to Figure 4 for the complete schematic.

JUMPER	TYPE	CIRCUIT	SOURCE FOLLOWER INTEGRATOR IN	SOURCE FOLLOWER INTEGRATOR OUT	JFET IN GAIN INTGRTR IN	JFET IN GAIN INTGRTR OUT
JP1	1x3	JFET drain	1,2	1,2	2,3	2,3
JP2	2x3	JFET source	1,2	1,2	5,6	3,4
JP3	1x3	LT1222 -input	1,2	1,2	2,3	2,3
JP4	1x3	photodiode bias	1,2	1,2	1,2	1,2
JP5	1x3	Integrator output	1,2	out	2,3	out
JP6	1x3	Integrator Input	1,2	2,3	1,2	2,3
JP7	1x2	LT1222 +input, Gnd	out	in	out	out
JP8	1x3	LT6230 vs LT6230-10	1,2 or 2,3	1,2 or 2,3	1,2 (Note 1)	1,2 (Note 1)

Note 1: With standard 1M TIA gain and small photodiode, JFET in Gain is not compatible with LT6230-10, as it oscillates.

LT6230, LT6230-10, LTC6240

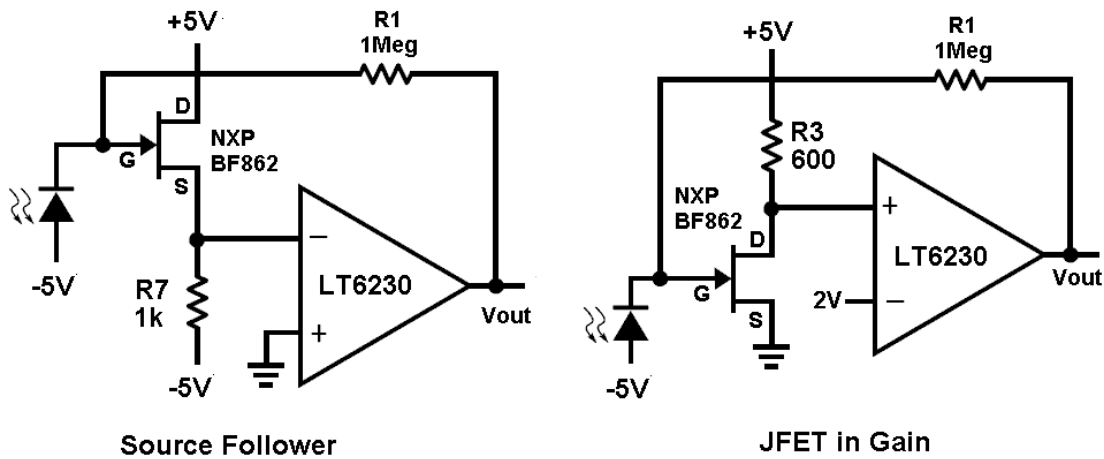

Figure 2. The two basic types of JFET configuration. The left shows the JFET as a source follower, simply buffering the feedback resistor to the opamp's inverting input. The right shows the JFET in gain, with source grounded. Because the JFET inverts, the feedback is now applied to the opamp's non-inverting input. In both cases, the effective input offset voltage is one JFET V_{gs} (about -400mV). The source follower configuration is the simplest and most versatile, but the JFET in Gain configuration offers the highest achievable gain-bandwidth product and the lowest voltage noise. Output noise at low and medium frequencies (10kHz to 100kHz) is 130nV/rtHz, dominated entirely by the feedback resistor.

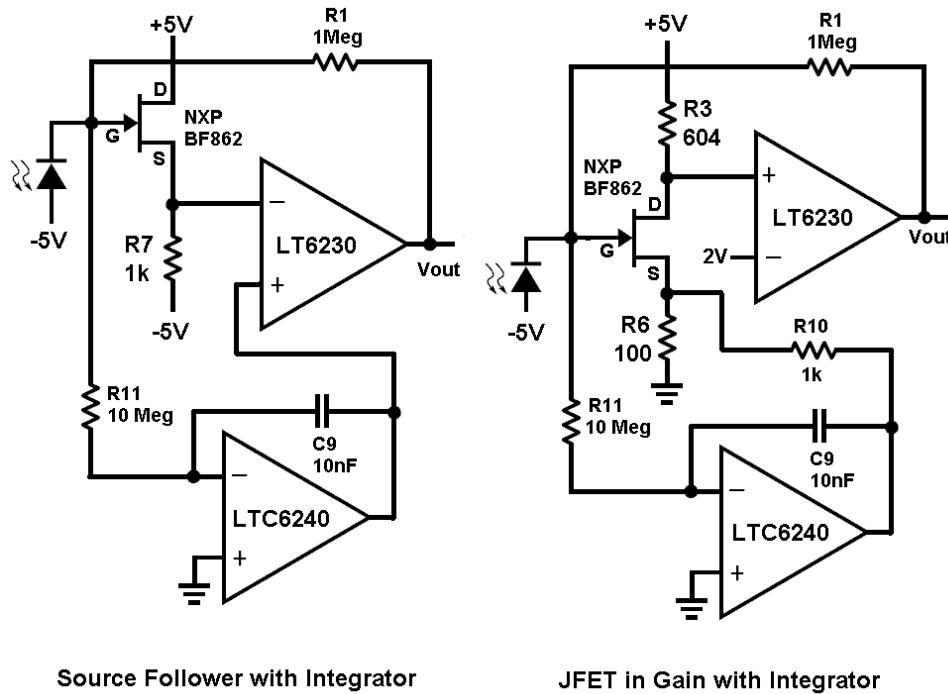
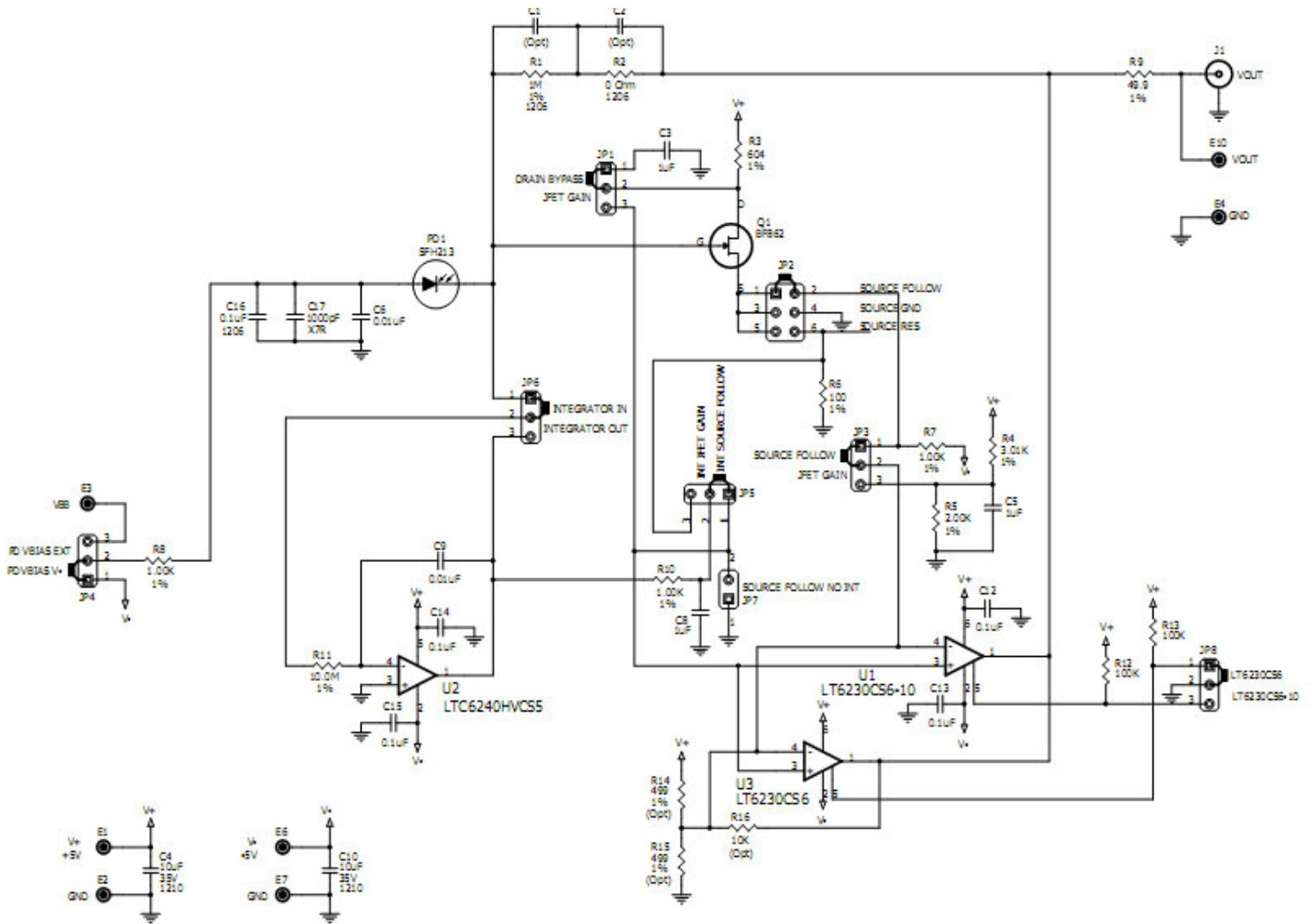

Figure 3. The two basic types of JFET configuration again, but shown with LTC6240 integrators which zero out the overall input offset voltage. On the left, the JFET V_{gs} is forced to the LT6230 non-inverting input. On the right, the integrator puts the JFET V_{gs} at the source directly. In both cases, the 10M sensing resistor R11 injects 40fA/√Hz of current noise, which is discernible but relatively small compared to the 130fA/√Hz of the 1M feedback resistor. The output noise at low to medium frequencies is about 136nV/√Hz.



X-ON Electronics

Largest Supplier of Electrical and Electronic Components

Click to view similar products for [Amplifier IC Development Tools](#) category:

Click to view products by [Analog Devices](#) manufacturer:

Other Similar products are found below :

[EVAL-ADCMP566BCPZ](#) [EVAL-ADCMP606BKSZ](#) [AD8013AR-14-EBZ](#) [AD8033AKS-EBZ](#) [AD8044AR-EBZ](#) [AD8225-EVALZ](#)
[ADA4859-3ACP-EBZ](#) [ADA4862-3YR-EBZ](#) [DEM-OPA-SO-2B](#) [AD744JR-EBZ](#) [AD8023AR-EBZ](#) [AD8030ARJ-EBZ](#) [AD8040ARU-EBZ](#)
[AD8073JR-EBZ](#) [AD813AR-14-EBZ](#) [AD848JR-EBZ](#) [ADA4858-3ACP-EBZ](#) [ADA4922-1ACP-EBZ](#) [551600075-001/NOPB](#) [DEM-OPA-SO-](#)
[2E](#) [THS7374EVM](#) [EVAL-ADCMP553BRMZ](#) [EVAL-ADCMP608BKSZ](#) [MIOP 42109](#) [EVAL-ADCMP609BRMZ](#) [MAX9928EVKIT+](#)
[MAX9636EVKIT+](#) [MAX9611EVKIT](#) [MAX9937EVKIT+](#) [MAX9934TEVKIT+](#) [MAX44290EVKIT#](#) [MAX2644EVKIT](#) [MAX4073EVKIT+](#)
[DEM-OPA-SO-2C](#) [MAX2643EVKIT](#) [ISL28158EVAL1Z](#) [MAX40003EVKIT#](#) [MAX2473EVKIT](#) [MAX2472EVKIT](#) [MAX4223EVKIT](#)
[MAX9700BEVKIT](#) [MADL-011014-001SMB](#) [DC1685A](#) [DEM-OPA-SO-2D](#) [MAX2670EVKIT#](#) [DEM-OPA-SO-1E](#) [AD8137YCP-EBZ](#)
[EVAL-ADA4523-1ARMZ](#) [MAX44242EVKIT#](#) [EVAL-LT5401_32FDAZ](#)