

Ultralow Power Boost Converter with Dual Half-Bridge Switches

DESCRIPTION

Demonstration circuit 1449A is an Ultralow Power Boost Converter with Dual Half-Bridge Switches featuring the LT8415. It converts a 3V-10V source to 16V supplying 1.6mA at 3V_{in} and 10mA at 10V_{in}. The 16V output is used to bias the Dual Half-Bridges which are activated by IN1 and IN2 and are pinned out at VOUT1 and VOUT2. IN1 controls VOUT1 with the same polarity and IN2 controls VOUT2. Each Half-Bridge drives a 200pF on-board capacitor.

The LT8415 features a low noise control scheme, integrated power switch, dual half-bridge switches, schottky diode and output disconnect function, ultra-low quiescent current, built in soft-start and overvoltage protection. The LT8415 datasheet gives a complete description of the part, its operation and application information. The

datasheet must be read in conjunction with this quick start guide for working on or modifying the demo circuit 1449.

This circuit is intended for space-conscious applications such as Sensor Power, RF Memos, Low Power Actuator Bias/Control, Liquid Lens Drivers and General Purpose Bias Supplies.

Design files for this circuit board are available. Call the LTC factory.

 , LTC, LTM, LT are registered trademarks of Linear Technology Corporation.

PERFORMANCE SUMMARY FOR DC1387A-A/LT8410 Specifications are at TA = 25°C

SYMBOL	PARAMETER	CONDITIONS	MIN	TYP	MAX	UNITS
V _{IN}	Input Supply Range		3		10	V
V _{OUT}	Output Voltage Range	V _{IN} = 3V, I _{LOAD} = 1.6mA	15.54	16	16.48	V
V _{OUT}	Output Voltage Range	V _{IN} = 10V, I _{LOAD} = 10mA	15.54	16	16.48	V
RIPPLE		V _{IN} = 10V, I _{LOAD} = 10mA		20		mV
EFFICIENCY		V _{IN} = 3V, I _{LOAD} = 1.6mA		73		%
EFFICIENCY		V _{IN} = 10V, I _{LOAD} = 10mA		83		%

QUICK START PROCEDURE

Demonstration circuit 1449 is easy to set up to evaluate the performance of the LT8415. Refer to Figure 1 for proper measurement equipment setup and follow the procedure below:

1. Place jumpers in the following positions:

JP1 Run

2. With power off, connect the input power supply to Vin and GND.
3. Turn on the power at the input.

Check for the proper output voltages. $V_{out} = 15.52V$ to $16.48V$.

NOTE. If there is no output, temporarily disconnect the load to make sure that the load is not set too high.

4. Once the proper output voltage is established, adjust the load within the operating range and observe the output voltage regulation, ripple voltage, efficiency and other parameters.
5. To test the VOUT1 and VOUT2 outputs, apply a logic level square wave signal (typically 0V to 2V) at IN1 and/or IN2 and observe the amplitude levels and associated delays at VOUT1 and VOUT2. See datasheet for response driving external capacitors.

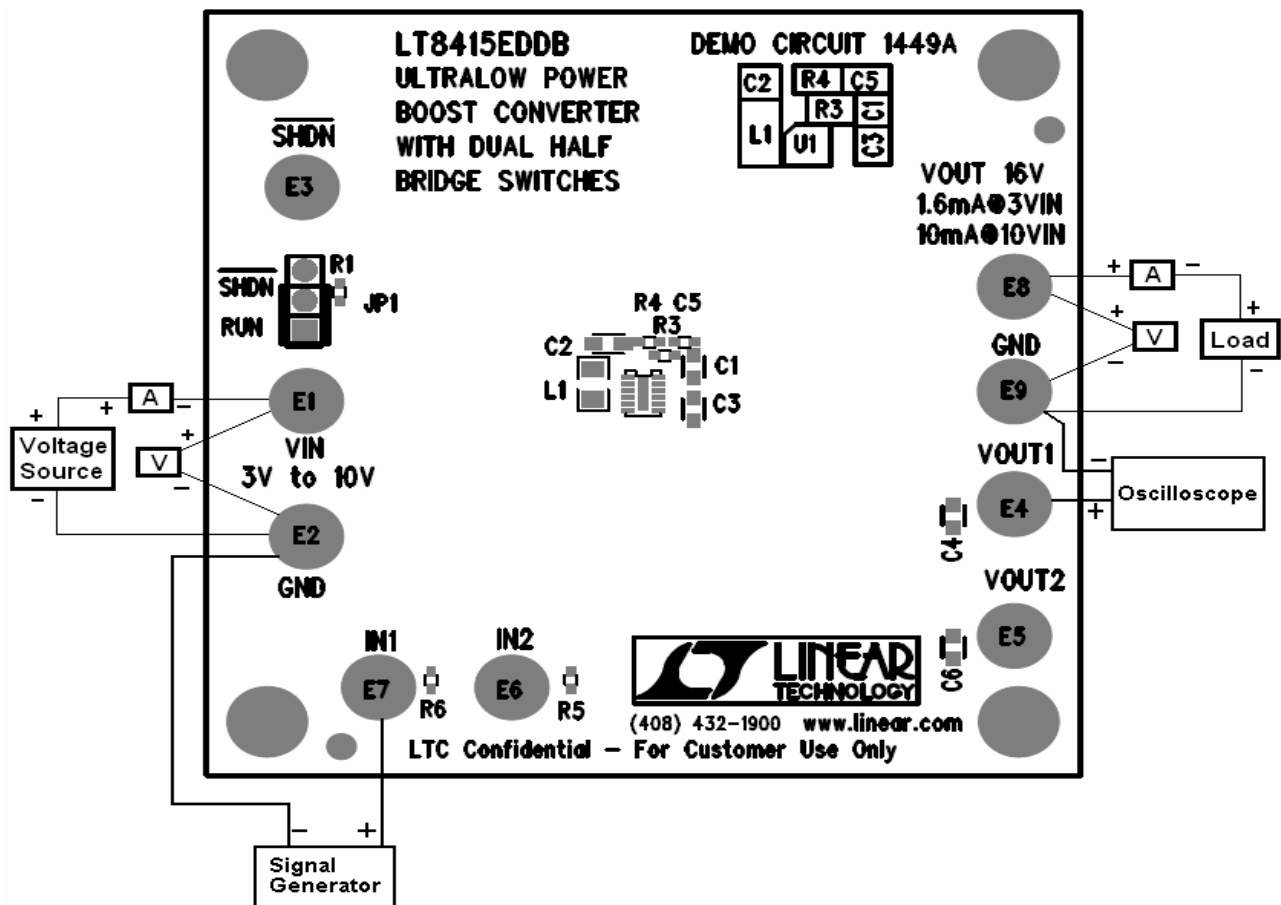
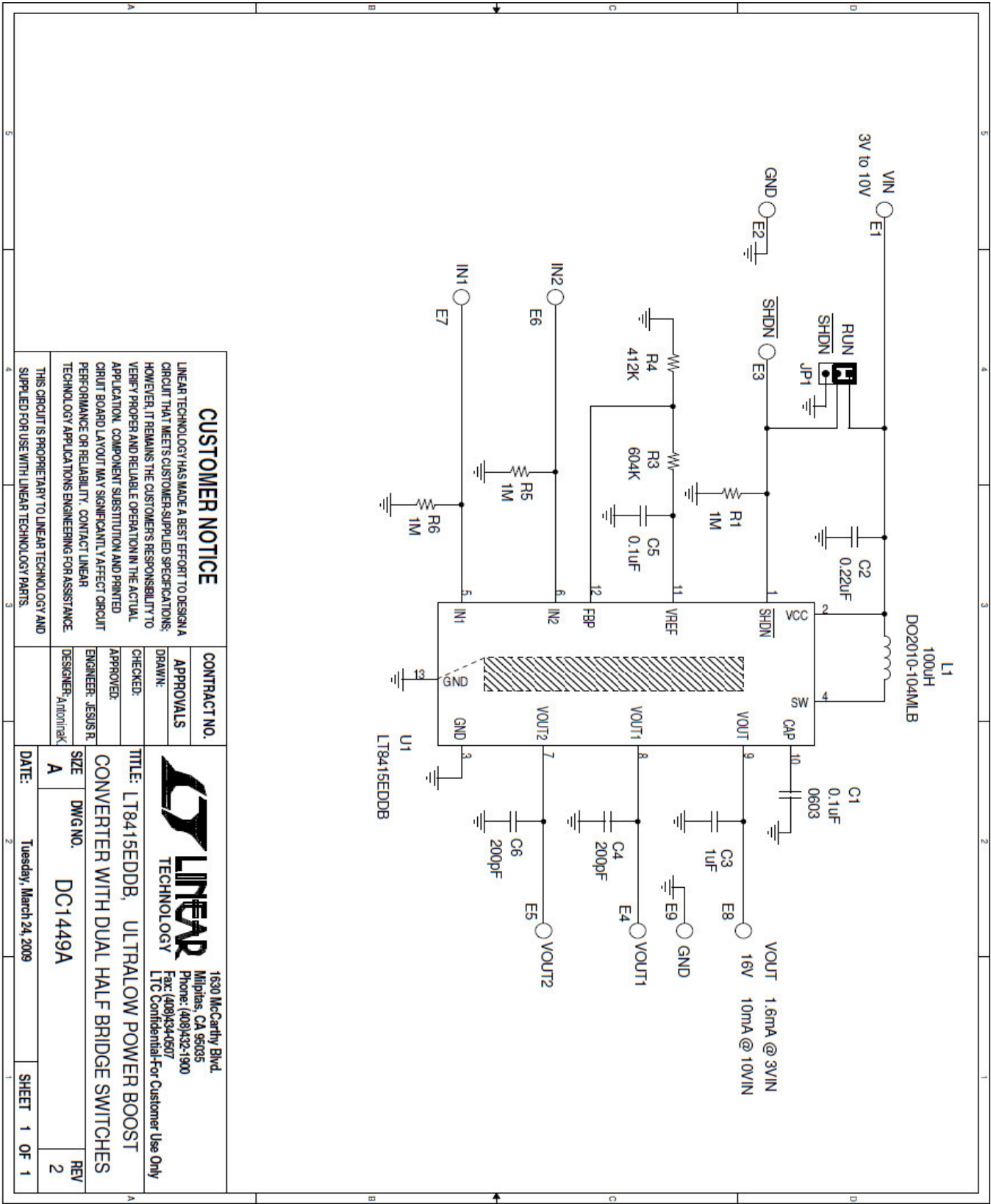

Figure 1. Proper Measurement Equipment Setup



CUSTOMER NOTICE

LINEAR TECHNOLOGY HAS MADE A BEST EFFORT TO DESIGN A CIRCUIT THAT MEETS CUSTOMER-SUPPLIED SPECIFICATIONS; HOWEVER, IT REMAINS THE CUSTOMER'S RESPONSIBILITY TO VERIFY PROPER AND RELIABLE OPERATION IN THE ACTUAL APPLICATION. COMPONENT SUBSTITUTION AND PRINTED CIRCUIT BOARD LAYOUT MAY SIGNIFICANTLY AFFECT CIRCUIT PERFORMANCE OR RELIABILITY. CONTACT LINEAR TECHNOLOGY APPLICATIONS ENGINEERING FOR ASSISTANCE.

THIS CIRCUIT IS PROPRIETARY TO LINEAR TECHNOLOGY AND SUPPLIED FOR USE WITH LINEAR TECHNOLOGY PARTS.

CONTRACT NO.	DESIGNER: Antoniak
APPROVALS	ENGINEER: JESUS R.
DRAWN:	CHECKED:
	APPROVED:

1630 McCarthy Blvd.
 Milpitas, CA 95035
 Phone: (408)432-1900
 Fax: (408)434-0607
 LTC Confidential-For Customer Use Only

LINEAR TECHNOLOGY

TITLE: LT8415EDDB, ULTRALOW POWER BOOST CONVERTER WITH DUAL HALF BRIDGE SWITCHES

DATE: Tuesday, March 24, 2009

SIZE: A
DWG NO.: DC1449A
REV: 2

SHEET 1 OF 1

X-ON Electronics

Largest Supplier of Electrical and Electronic Components

Click to view similar products for [Power Management IC Development Tools](#) category:

Click to view products by [Analog Devices](#) manufacturer:

Other Similar products are found below :

[EVAL-ADM1168LQEBZ](#) [EVB-EP5348UI](#) [MIC23451-AAAYFL EV](#) [MIC5281YMME EV](#) [DA9063-EVAL](#) [ADP122-3.3-EVALZ](#) [ADP130-0.8-EVALZ](#) [ADP130-1.2-EVALZ](#) [ADP130-1.5-EVALZ](#) [ADP130-1.8-EVALZ](#) [ADP1714-3.3-EVALZ](#) [ADP1716-2.5-EVALZ](#) [ADP1740-1.5-EVALZ](#) [ADP1752-1.5-EVALZ](#) [ADP1828LC-EVALZ](#) [ADP1870-0.3-EVALZ](#) [ADP1871-0.6-EVALZ](#) [ADP1873-0.6-EVALZ](#) [ADP1874-0.3-EVALZ](#) [ADP1882-1.0-EVALZ](#) [ADP199CB-EVALZ](#) [ADP2102-1.25-EVALZ](#) [ADP2102-1.875EVALZ](#) [ADP2102-1.8-EVALZ](#) [ADP2102-2-EVALZ](#) [ADP2102-3-EVALZ](#) [ADP2102-4-EVALZ](#) [ADP2106-1.8-EVALZ](#) [ADP2147CB-110EVALZ](#) [AS3606-DB](#) [BQ24010EVM](#) [BQ24075TEVM](#) [BQ24155EVM](#) [BQ24157EVM-697](#) [BQ24160EVM-742](#) [BQ24296MEVM-655](#) [BQ25010EVM](#) [BQ3055EVM](#) [NCV891330PD50GEVB](#) [ISLUSBI2CKIT1Z](#) [LM2744EVAL](#) [LM2854EVAL](#) [LM3658SD-AEV/NOPB](#) [LM3658SDEV/NOPB](#) [LM3691TL-1.8EV/NOPB](#) [LM4510SDEV/NOPB](#) [LM5033SD-EVAL](#) [LP38512TS-1.8EV](#) [EVAL-ADM1186-1MBZ](#) [EVAL-ADM1186-2MBZ](#)