

ULTRALOW POWER 15mA HIGH EFFICIENCY STEP-DOWN CONVERTER LTC3620EDC

DESCRIPTION

Demonstration circuit 1460A is a high efficiency step-down converter featuring the LTC3620EDC with internal high side and synchronous power switches that draws only 18 μ A of quiescent current. It has an internal frequency clamp that forces a minimum switching frequency at light loads to minimize noise in the audio range. Its input voltage ranges between 2.9V and 5.5V. If the input voltage falls below 2.8V, an undervoltage lockout circuit will shut down the part. The demo circuit

provides selectable jumper outputs for 1.1V, 1.2V and 1.8V. The output can supply up to 15mA of load current. Gerber files for this circuit are available. Call the LTC Factory.

LT, LTC, LTM, LT, Burst Mode, OPTI-LOOP, Over-The-Top and PolyPhase are registered trademarks of Linear Technology Corporation. Adaptive Power, C-Load, DirectSense, Easy Drive, FilterCAD, Hot Swap, LinearView, μ Module, Micropower SwitcherCAD, Multimode Dimming, No Latency $\Delta\Sigma$, No Latency Delta-Sigma, No RSENSE, Operational Filter, Panel-Protect, PowerPath, PowerSOT, SmartStart, SoftSpan, Stage Shedding, SwitcherCAD, ThinSOT, UltraFast and VLDO are trademarks of Linear Technology Corporation. Other product names may be trademarks of the companies that manufacture the products.

Table 1. Performance Summary (TA = 25°C)

PARAMETER	CONDITION	VALUE
Input Voltage Range V _{IN}		2.9V to 5.5V
Output Voltage V _{OUT}	V _{IN} =3.6V	V _{OUT} \pm 1.4% (LTC3620EDC Output adj. version) V _{OUT} \pm 1% (LTC3620-1EDC Fixed 1.1V version)
Maximum Output Current		15mA
DC Quiescent Current	No switching, V _{FB} =0.65V, SW Pin Floating	18 μ A
Minimum Switching Frequency (Internal)	V _{FB} =0.65V, f _{MIN} /MODE=0	50kHz

QUICK START PROCEDURE

The DC1460A is easy to set up to evaluate the performance of the LTC3620EDC. For a proper measurement equipment configuration, set up the circuit according to the diagram in Figure 2.

NOTE. When measuring the input or output voltage ripple, care must be taken to avoid a long ground lead on the oscilloscope probe. Measure the input or output voltage ripple by touching the probe tip directly across the VIN or VOUT and GND terminals. See the Measurement Equipment Set-up diagram in Figure 1 for proper scope probe technique.

Please follow the procedure outlined below for proper operation.

1. Connect the input power supply to the VIN and GND terminals. Connect the load between the VOUT and GND terminals. Refer to Figure 2 for the proper measurement equipment setup.
2. Before proceeding to operation, insert jumper shunt XJP1 into the OFF position and insert a shunt jumper

into JP2, JP3 or JP4 for voltages of 1.8V, 1.2V or 1.1V respectively. Set the load output current to 12ma.

3. Apply 3.6V at VIN. Measure VOUT; it should read 0V. If desired, one can measure the shutdown supply current at this point. The supply current will be about <1 μ A in shutdown. Set the load output current back to 0mA.
4. Turn on VOUT by changing shunt XJP1 from the OFF position to the ON position. The output voltage should measure according to the voltage set by the shunt jumper in JP2.
5. Set the load output current to 5mA. Vary the input voltage from 3.0V to 5.5V and VOUT should be within a tolerance of \pm 0.38%.

DC1460A

- Set the input voltage to 3.6V. Vary the VOUT load current from 1mA to 12mA, and the output voltage should be within a tolerance of $\pm 0.5\%$ (typical). As the load is varied, there should not be any audible noise generated by the demo circuit.

Warning. If the power for the demo board is carried in long leads, the input voltage at the part could “ring”, which could affect the operation of the circuit or even exceed the maximum voltage rating of the IC. To eliminate the ringing, insert an electrolytic capacitor (for instance, Panasonic part # EEAFC1A220 (22 μ F/10V) on the pads between the input power and return terminals on the bottom of the demo board. The (greater) ESR of the electrolytic will dampen the (possible) ringing voltage due to the use of long input leads. On a normal, typical PCB, with short traces, the capacitor is not needed.

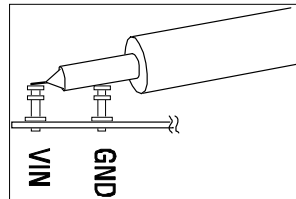

Figure 1. Measuring Input or Output Voltage Ripple

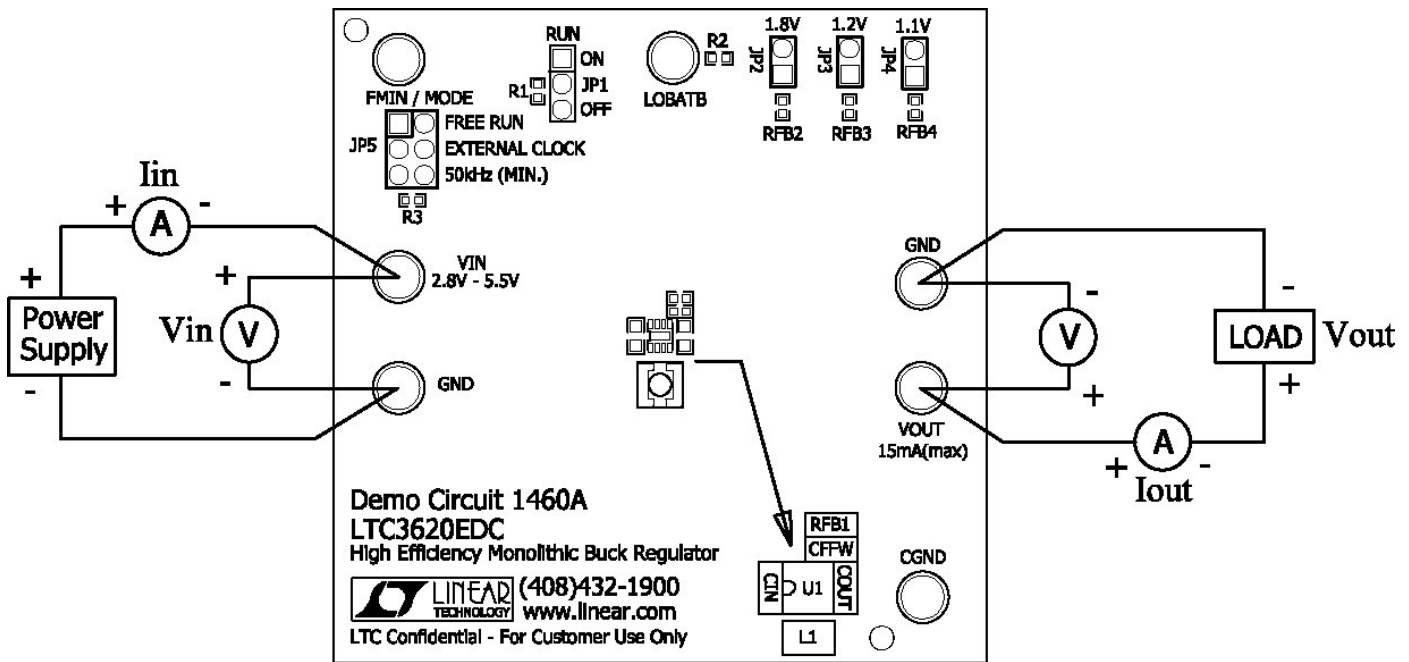

Figure 2. Equipment Setup to Test LTC3620EDC

INDUCTOR COMPARISON

Demonstration circuit 1460A comes with a standard inductor (Coilcraft LPS3010-223ML) optimized for size and efficiency. For handheld applications requiring minimal board area, this inductor can be replaced with a small surface mount 0603 package inductor, for ex-

ample, the Taiyo-Yuden CBMF1608T220K. Figure 3 shows the inductor size comparison on the demonstration board while Figure 4 shows the efficiency performance of these two inductors.

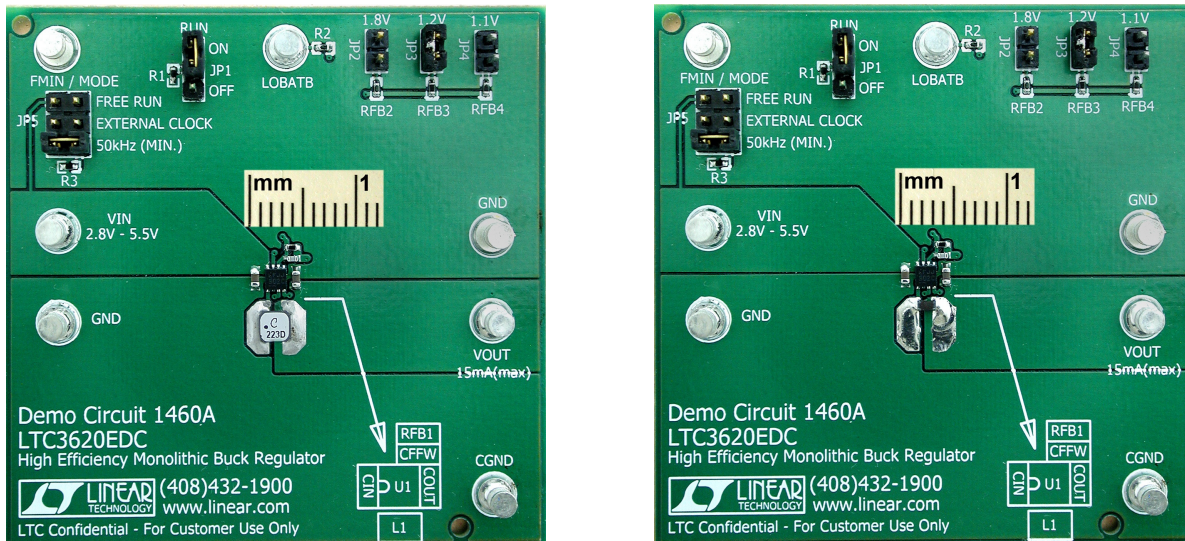

Figure 3. LTC3620EDC Operating with Different Size Inductors

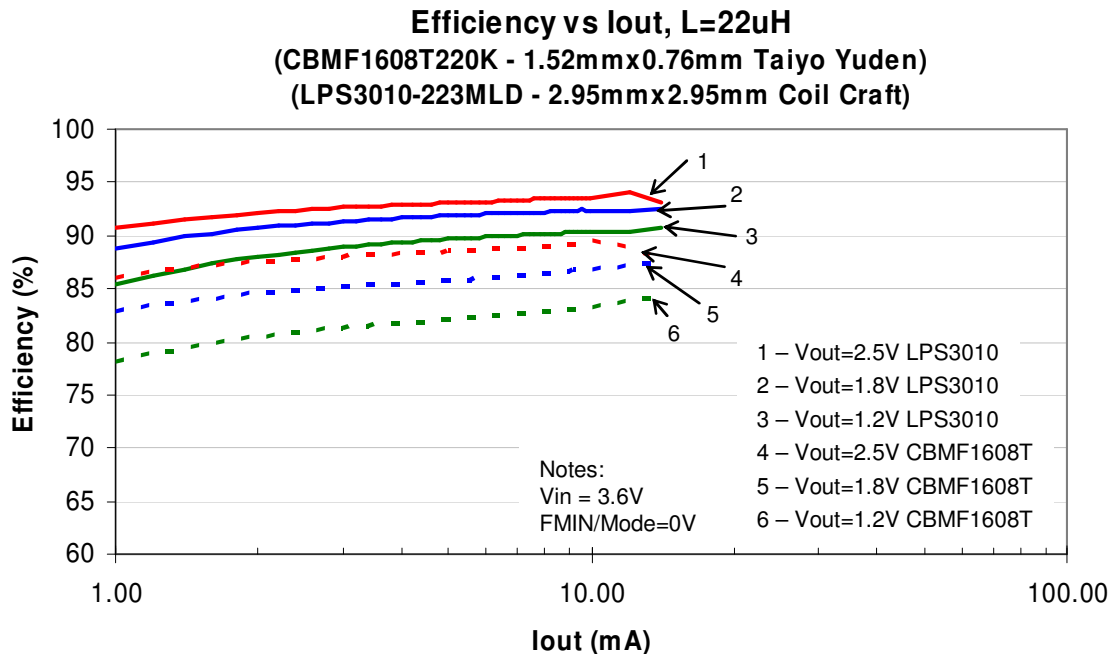
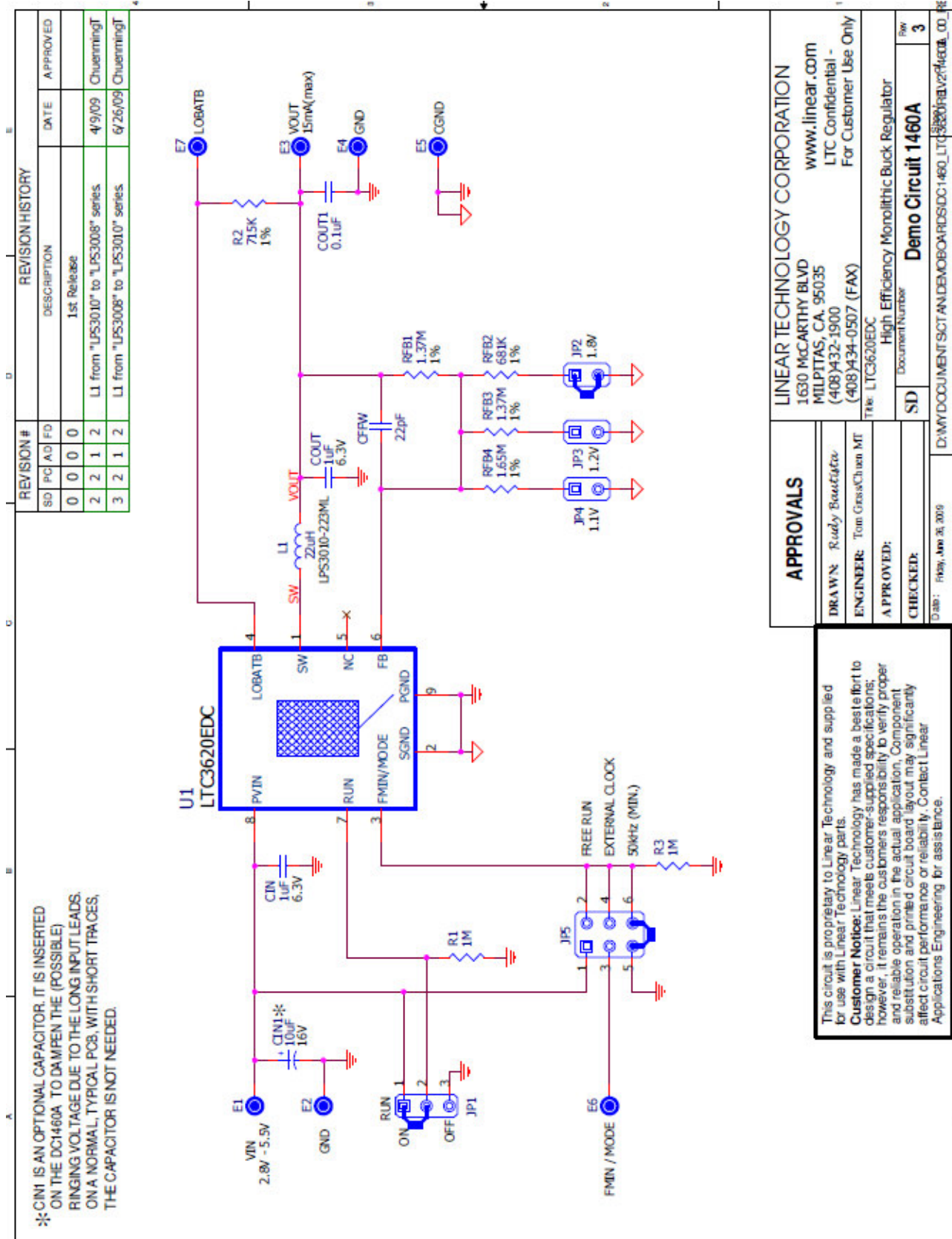

Figure 4. Typical Efficiency vs. Load Current for Different Inductors



<i>Item</i>	<i>Qty</i>	<i>Reference</i>	<i>Part Description</i>	<i>Manufacturer / Part #</i>
REQUIRED CIRCUIT COMPONENTS				
1	1	CFFW	Cap., NPO 22pF 25V 10%	AVX 04023A220KAT2A
2	2	COUT,CIN	Cap., X5R 1uF 6.3V 10%	Taiyo Yuden JMK107BJ105KA-T
3	1	CIN1	Cap., Tant. 10uF 16V 20%	AVX TAJT106M016R
4	1	L1	Inductor, 22uH	Coilcraft LPS3010-223
5	1	RFB1	Res., Chip 1.37M 0.06W 1%	Vishay CRCW04021M37FKED
6	1	RFB2	Res., Chip 681K 0.06W 1%	Vishay CRCW0402681KFKED
7	2	R1,R3	Res., Chip 1M 0.06W 5%	Vishay CRCW04021M00JNED
8	1	R2	Res., Chip 715K 0.06W 1%	Vishay CRCW0402715KFKED
9	1	U1	I.C., Volt. Reg.	Linear Tech. Corp. LTC3620EDC
ADDITIONAL DEMO BOARD CIRCUIT COMPONENTS				
1	1	COUT1	Cap., X5R 0.1uF 25V 10%	AVX 06033D104KAT2A
HARDWARE FOR DEMO BOARD ONLY				
1	7	E1,E2,E3,E4,E5,E6,E7	Turret, Testpoint	Mill Max 2501-2-00-80-00-00-07-0
2	1	JP1	Headers, 3 Pins 2mm Ctrs.	Samtec TMM-103-02-L-S
3	3	JP2,JP3,JP4	Jumper, 2 Pins 2mm Ctrs.	Samtec TMM-102-02-L-S
4	1	JP5	Headers, Dbl. Row 2 x 3 2mm Ctrs.	Samtec TMM-103-02-L-D
5	1	RFB3	Res., Chip 1.37M 0.06W 1%	Vishay CRCW04021M37FKED
6	1	RFB4	Res., Chip 1.65M 0.06W 1%	Vishay CRCW04021M65FKED
7	3	XJP1,XJP2,XJP5	Shunt, 2mm Ctrs.	Samtec 2SN-BK-G
8	1		FAB, PRINTED CIRCUIT BOARD	DEMO CIRCUIT #1460A
9	1		STENCIL	STENCIL 1460A

X-ON Electronics

Largest Supplier of Electrical and Electronic Components

Click to view similar products for [Power Management IC Development Tools](#) category:

Click to view products by [Analog Devices](#) manufacturer:

Other Similar products are found below :

[EVAL-ADM1168LQEBZ](#) [EVB-EP5348UI](#) [MIC23451-AAAYFL EV](#) [MIC5281YMME EV](#) [DA9063-EVAL](#) [ADP122-3.3-EVALZ](#) [ADP130-0.8-EVALZ](#) [ADP130-1.2-EVALZ](#) [ADP130-1.5-EVALZ](#) [ADP130-1.8-EVALZ](#) [ADP1714-3.3-EVALZ](#) [ADP1716-2.5-EVALZ](#) [ADP1740-1.5-EVALZ](#) [ADP1752-1.5-EVALZ](#) [ADP1828LC-EVALZ](#) [ADP1870-0.3-EVALZ](#) [ADP1871-0.6-EVALZ](#) [ADP1873-0.6-EVALZ](#) [ADP1874-0.3-EVALZ](#) [ADP1882-1.0-EVALZ](#) [ADP199CB-EVALZ](#) [ADP2102-1.25-EVALZ](#) [ADP2102-1.875EVALZ](#) [ADP2102-1.8-EVALZ](#) [ADP2102-2-EVALZ](#) [ADP2102-3-EVALZ](#) [ADP2102-4-EVALZ](#) [ADP2106-1.8-EVALZ](#) [ADP2147CB-110EVALZ](#) [AS3606-DB](#) [BQ24010EVM](#) [BQ24075TEVM](#) [BQ24155EVM](#) [BQ24157EVM-697](#) [BQ24160EVM-742](#) [BQ24296MEVM-655](#) [BQ25010EVM](#) [BQ3055EVM](#) [NCV891330PD50GEVB](#) [ISLUSBI2CKIT1Z](#) [LM2744EVAL](#) [LM2854EVAL](#) [LM3658SD-AEV/NOPB](#) [LM3658SDEV/NOPB](#) [LM3691TL-1.8EV/NOPB](#) [LM4510SDEV/NOPB](#) [LM5033SD-EVAL](#) [LP38512TS-1.8EV](#) [EVAL-ADM1186-1MBZ](#) [EVAL-ADM1186-2MBZ](#)