

LT3597

60V Triple Step-Down LED Driver

DESCRIPTION

Demonstration circuit 1497A is a 60V triple step-down LED driver featuring the LT3597. The demo board is optimized for 9 white LEDs, 100mA output per regulator from a 48V input. When different number or different color of LEDs is used for evaluation, attentions should be given to the maximum output voltage setting and fault reporting. The connections between the board and LEDs strings should be as short as feasible.

The circuit achieves 10,000:1 PWM dimming at 100Hz PWM frequency. LED dimming can also be done by analog control of the CTRL1-3 pin. If dimming is not required, leave the PWM1-3 and CTRL1-3 terminals unconnected.

The demo circuit pulls PWM1-3 and CTRL1-3 pins up to V_{REF} . The switching frequency is set to 1MHz on the demo circuit for best solution size. The LT3597 internal compensation makes it a lot easier for a designer to design different application circuits.

The LT3597 data sheet gives a complete description of the part, operation and application information. The data sheet must be read in conjunction with this quick start guide for demo circuit 1497A.

Design files for this circuit board are available at <http://www.linear.com/demo>

LT, LT, LTC, LTM, μ Module, Linear Technology and the Linear logo are registered trademarks of Linear Technology Corporation. All other trademarks are the property of their respective owners.

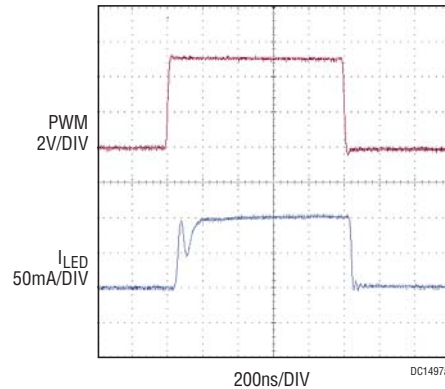

Figure 1. PWM Dimming

DEMO MANUAL DC1497A

PERFORMANCE SUMMARY (T_A = 25°C)

SYMBOL	PARAMETER	CONDITIONS	MIN	TYP	MAX	UNITS
V _{IN} *	Input Supply		6		55	V
V _{LED}	LED String Voltage		28		34	V
V _{OUT(MAX)}	Maximum Output Voltage			38		V
I _{OUT}	Output Current	R23 = R24 = R25 = 20k	98	100	102	mA
DIM	PWM Dimming Ratio	PWM Dimming Frequency = 100Hz		10,000:1		
FSW	Switching Frequency	R22 = 33.2k	0.9	1	1.1	MHz
EFE	Efficiency	V _{IN} = 48V, V _{OUT} = 29V, I _{OUT} = 100mA, BIAS = 5V, No Dimming		87		%

*Actual V_{IN} range should be determined by the load. For 9 white LEDs per channel, use a 48V input for evaluation.

QUICK START PROCEDURE

Demonstration circuit 1497A is easy to set up to evaluate the performance of the LT3597. Refer to Figure 2 for proper measurement equipment setup and follow the procedure below:

1. With power off, connect the input power supply to V_{IN} and GND.
2. With power off, connect a 5V bias supply to BIAS and GND. Bias voltage should be less than 25V.
3. With power off, connect 3 LED strings, 9 white LEDs per string, between LED1+ and LED1-, LED2+ and LED2-, LED3+ and LED3- respectively.
4. Turn on the power at the input. Be careful not to look at the LEDs directly.
5. Carefully evaluate all design parameters as needed.
6. To evaluate PWM dimming, apply a PWM signal to PWM1, PWM2 and/or PWM3. To evaluate 10,000:1 PWM dimming, the PWM signal should have a frequency of 100Hz and the minimum pulse width can be as low as 1 μ s.
7. To modify the demo board for other applications, please contact the Linear Applications Group for help.

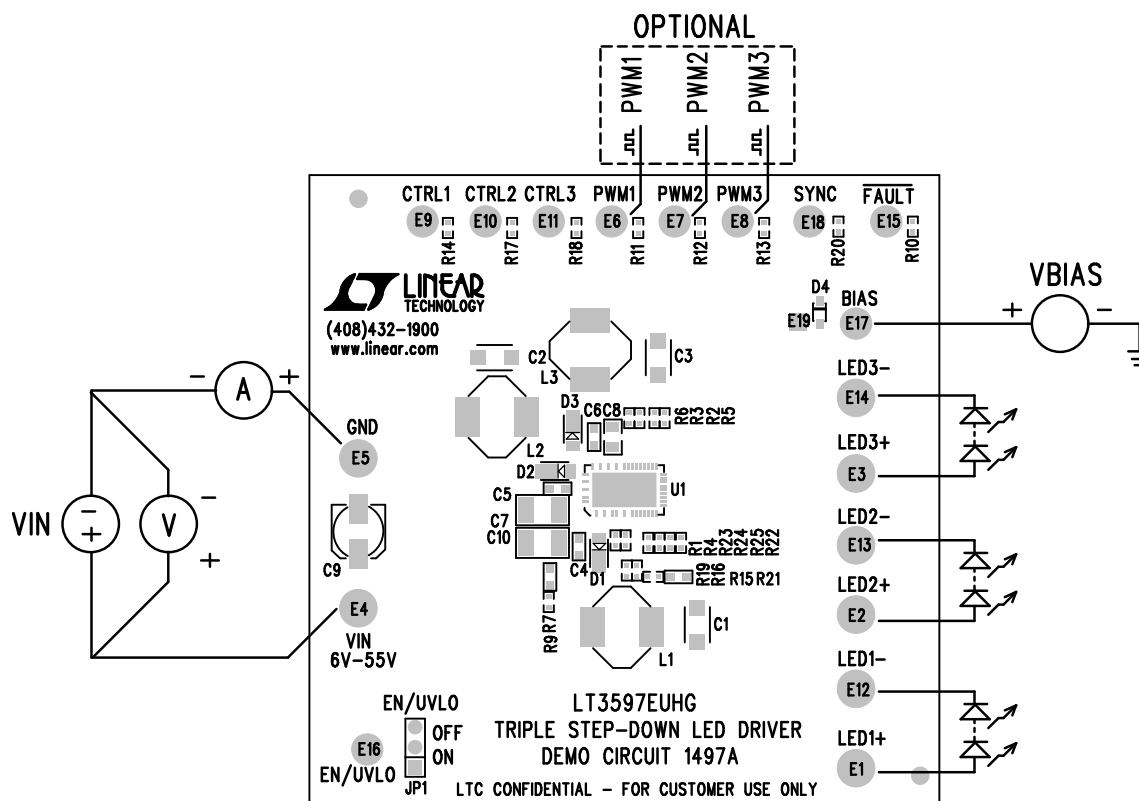

Figure 2. Demo Board Setup

DEMO MANUAL DC1497A

PARTS LIST

ITEM	QTY	REFERENCE	PART DESCRIPTION	MANUFACTURER/PART NUMBER
Required Circuit Components				
1	3	C1, C2, C3	Capacitor, X7R, 4.7 μ F, 50V, 10%, 1206	Murata, GRM31CR71H475KA12L
2	3	C4, C5, C6	Capacitor, X7R, 0.22 μ F, 25V, 10%, 0603	Murata, GRM188R71E224KA88L
3	2	C7, C10	Capacitor, X7R, 2.2 μ F, 100V, 10%, 1210	Murata, GRM32ER72A225KA35L
4	1	C8	Capacitor, X5R, 4.7 μ F, 25V, 10%, 0805	Taiyo Yuden, TMK212BJ475KG-T
5	3	D1, D2, D3	Diode, Schottky, Power DI-123	Diodes/Zetex, DFSL160-7
6	3	L1, L2, L3	Inductor, 100 μ H	Sumida, CDR6D28MNNP-101NC
7	3	R1, R2, R3	Resistor, Chip, 93.1k, 1/16W, 1%, 0402	Vishay, CRCW040293K1FKED
8	3	R4, R5, R6	Resistor, Chip, 3.01k Ω , 1/16W, 1%, 0402	Vishay, CRCW04023K01FKED
9	1	R16	Resistor, Chip, 82.5k Ω , 1/16W, 1%, 0402	Vishay, CRCW040282K5FKED
10	1	R19	Resistor, Chip, 49.9k Ω , 1/16W, 1%, 0402	Vishay, CRCW040249K9FKED
11	1	R20	Resistor, Chip, 10k Ω , 1/16W, 1%, 0402	Vishay, CRCW040210K0FKED
12	1	R22	Resistor, Chip, 33.2k Ω , 1/16W, 1%, 0402	Vishay, CRCW040233K2FKED
13	3	R23, R24, R25	Resistor, Chip, 20k Ω , 1/16W, 1%, 0402	Vishay, CRCW040220K0FKED
14	1	U1	I.C. LT3597EUHG, 52-Pin QFN-5mm \times 8mm	Linear Technology, LT3597EUHG
Additional Demo Board Circuit Components				
1	1	C9	Capacitor, Aluminum 4.7 μ F, 63V	Sun Electric, 63CE4R7BS
2	0	D4	Diode, OPT, SOD-323	
3	1	R7	Resistor, Chip, 270k Ω , 1/16W, 1%, 0603	Vishay, CRCW0603270KFKEA
4	1	R9	Resistor, Chip, 91k Ω , 1/16W, 1%, 0402	Vishay, CRCW040291K0FKED
5	7	R10-R14, R17, R18	Resistor, Chip, 100k Ω , 1/16W, 1%, 0402	Vishay, CRCW0402100KFKEA
6	1	R15	Resistor, Chip, 8.87k Ω , 1/16W, 1%, 0402	Vishay, CRCW04028K87FKED
7	1	R21	Thermistor, Chip, 100k, 1%, 0603	Murata, NCP18WF104F12RB
Hardware – For Demo Board Only				
1	8	E1-E5, E12-E14	Turret, Testpoint, 091"	Mill Max 2501-2-00-80-00-00-07-0
2	10	E6-E11, E15-E18	Turret, Testpoint, 063"	Mill Max 2308-2-00-80-00-00-07-0
3	1	JP1	Jumper, 3-Pin 1 Row .079CC	Samtec, TMM-103-02-L-S
4	1	SHUNT FOR PJ1	Shunt, .079" Center	Samtec, 2SN-BK-G
5	4		Stand-Off, Nylon 0.5" Tall	Keystone, 8833 (Snap On)

SCHEMATIC DIAGRAM

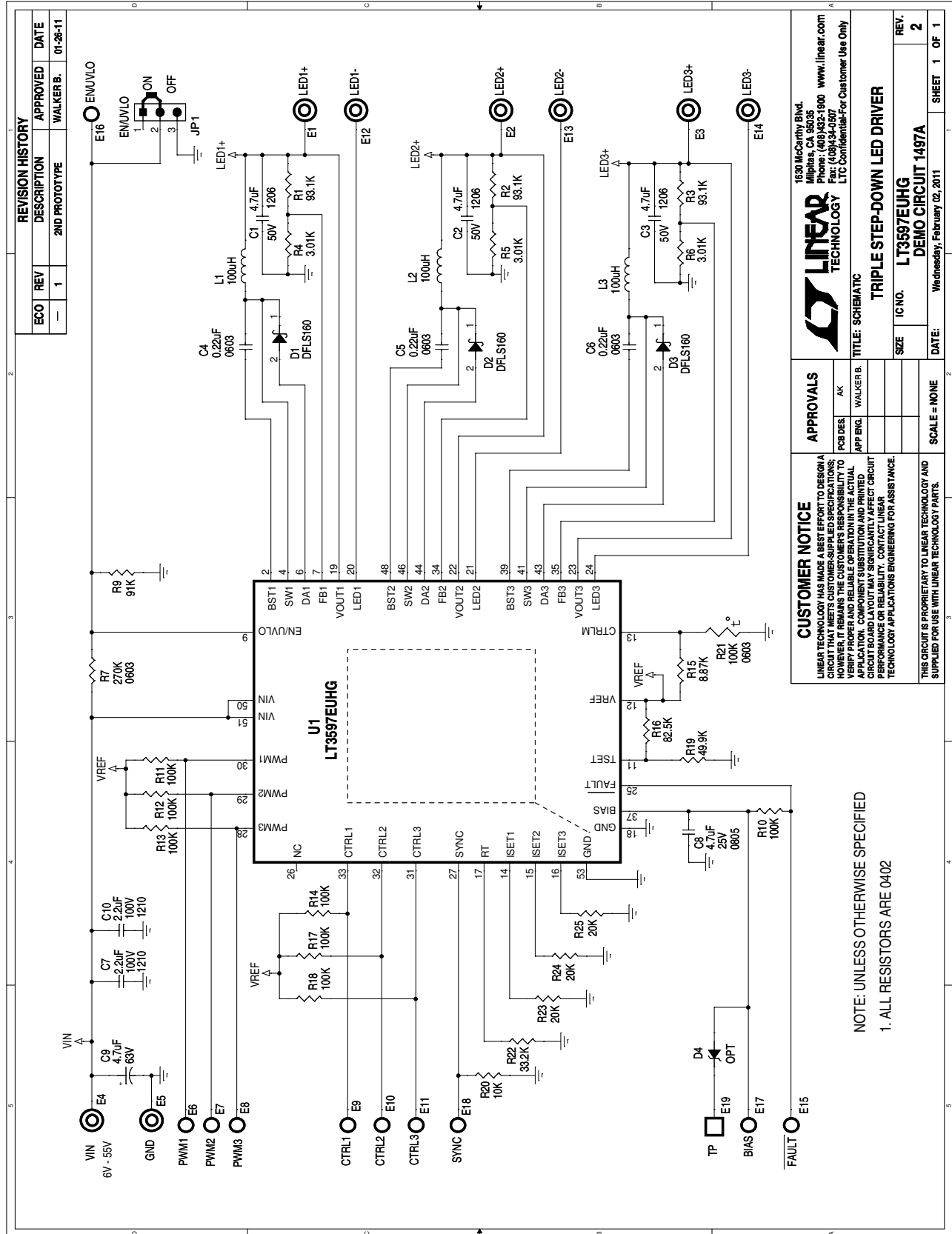

dc1497af

DEMO MANUAL DC1497A

DEMONSTRATION BOARD IMPORTANT NOTICE

Linear Technology Corporation (LTC) provides the enclosed product(s) under the following **AS IS** conditions:

This demonstration board (DEMO BOARD) kit being sold or provided by Linear Technology is intended for use for **ENGINEERING DEVELOPMENT OR EVALUATION PURPOSES ONLY** and is not provided by LTC for commercial use. As such, the DEMO BOARD herein may not be complete in terms of required design-, marketing-, and/or manufacturing-related protective considerations, including but not limited to product safety measures typically found in finished commercial goods. As a prototype, this product does not fall within the scope of the European Union directive on electromagnetic compatibility and therefore may or may not meet the technical requirements of the directive, or other regulations.

If this evaluation kit does not meet the specifications recited in the DEMO BOARD manual the kit may be returned within 30 days from the date of delivery for a full refund. **THE FOREGOING WARRANTY IS THE EXCLUSIVE WARRANTY MADE BY THE SELLER TO BUYER AND IS IN LIEU OF ALL OTHER WARRANTIES, EXPRESSED, IMPLIED, OR STATUTORY, INCLUDING ANY WARRANTY OF MERCHANTABILITY OR FITNESS FOR ANY PARTICULAR PURPOSE. EXCEPT TO THE EXTENT OF THIS INDEMNITY, NEITHER PARTY SHALL BE LIABLE TO THE OTHER FOR ANY INDIRECT, SPECIAL, INCIDENTAL, OR CONSEQUENTIAL DAMAGES.**

The user assumes all responsibility and liability for proper and safe handling of the goods. Further, the user releases LTC from all claims arising from the handling or use of the goods. Due to the open construction of the product, it is the user's responsibility to take any and all appropriate precautions with regard to electrostatic discharge. Also be aware that the products herein may not be regulatory compliant or agency certified (FCC, UL, CE, etc.).

No License is granted under any patent right or other intellectual property whatsoever. **LTC assumes no liability for applications assistance, customer product design, software performance, or infringement of patents or any other intellectual property rights of any kind.**

LTC currently services a variety of customers for products around the world, and therefore this transaction **is not exclusive**.

Please read the DEMO BOARD manual prior to handling the product. Persons handling this product must have electronics training and observe good laboratory practice standards. **Common sense is encouraged.**

This notice contains important safety information about temperatures and voltages. For further safety concerns, please contact a LTC application engineer.

Mailing Address:

Linear Technology
1630 McCarthy Blvd.
Milpitas, CA 95035

Copyright © 2004, Linear Technology Corporation

X-ON Electronics

Largest Supplier of Electrical and Electronic Components

Click to view similar products for [LED Lighting Development Tools](#) category:

Click to view products by [Analog Devices](#) manufacturer:

Other Similar products are found below :

[MIC2870YFT EV](#) [ADP8860DBCP-EVALZ](#) [LM3404MREVAL](#) [ADM8843EB-EVALZ](#) [TDGL014](#) [ISL97682IRTZEVALZ](#) [LM3508TLEV](#)
[EA6358NH](#) [MAX16826EVKIT](#) [MAX16839EVKIT+](#) [TPS92315EVM-516](#) [MAX1698EVKIT](#) [MAX6956EVKIT+](#) [OM13321,598](#) [DC986A](#)
[DC909A](#) [DC824A](#) [STEVAL-LLL006V1](#) [IS31LT3948-GRLS4-EB](#) [104PW03F](#) [PIM526](#) [PIM527](#) [MAX6946EVKIT+](#) [MAX20070EVKIT#](#)
[MAX21610EVKIT#](#) [MAX20090BEVKIT#](#) [MAX20092EVSYS#](#) [PIM498](#) [AP8800EV1](#) [ZXLD1370/1EV4](#) [MAX6964EVKIT](#)
[MAX25240EVKIT#](#) [MAX25500TEVKITC#](#) [MAX77961BEVKIT06#](#) [1216.1013](#) [TPS61176EVM-566](#) [TPS61197EVM](#) [TPS92001EVM-628](#)
[1270](#) [1271.2004](#) [1272.1030](#) [1273.1010](#) [1278.1010](#) [1279.1002](#) [1279.1001](#) [1282.1000](#) [1293.1900](#) [1293.1800](#) [1293.1700](#) [1293.1500](#)