

LT4180 Virtual Remote Sense Controller

DESCRIPTION

Demonstration circuit 1504A features the LT4180, a virtual remote sense controller which eliminates the need for remote sense wires to compensate for IR losses in cables and wires, and is used in conjunction with the LT3693 buck converter. The circuit is designed for an input voltage range of 8V to 36V with an output of 5V at 3A. The circuit board has a total wire resistance of 0.4Ω and a voltage drop of 1.2V. The circuit contains five selectable jumpers. JP1 turns the converter ON or Off, JP2-JP4 allow for easy selection of other dither frequency combinations, and

JP5 enables or disables spread spectrum operation. The LT4180 data sheet gives a complete description of the part, its operation and application information. The data sheet must be read in conjunction with this quick start guide for working on or modifying the demo circuit 1504A.

Design files for this circuit board are available at <http://www.linear.com/demo>

LT, LT, LTC, LTM, Linear Technology and the Linear logo are registered trademarks of Linear Technology Corporation. All other trademarks are the property of their respective owners.

PERFORMANCE SUMMARY (T_A = 25°C)

SYMBOL	PARAMETER	CONDITIONS	MIN	TYP	MAX	UNITS
V _{IN}	Input Supply Range		8		36	V
V _{OUT}	Output Voltage Accuracy	V _{IN} = 8V to 36V, I _{LOAD} = 3A	4.8V	5	5.2V	V
Ripple		V _{IN} = 12V, I _{LOAD} = 3A		50		mV
f _S	Buck Switching Frequency			500		KHz

QUICK START PROCEDURE

Demonstration circuit 1504A is easy to set up to evaluate the performance of the LT4180. Refer to Figure 2 for proper equipment setup and follow the procedure below.

When input or output voltage ripple is measured, care must be taken to avoid a long ground lead on the oscilloscope probe. Measure the input or output voltage ripple by touching the probe tip directly across the V_{IN} or V_{OUT} and GND terminals. See Figure 2 for proper scope probe technique.

1. Place jumpers in the following position:

- JP1 On
- JP2 Low
- JP3 High
- JP4 High
- JP5 Low

QUICK START PROCEDURE

2. With power off, connect the input power supply to V_{IN} and GND.

Apply 8V to input.

Check for the proper output voltage.

NOTE. If there is no output, temporarily disconnect the load to make sure that the load is not set too high.

Once the proper output voltage is established, adjust the input voltage and load within the operating range and observe the output voltage regulation, ripple voltage, efficiency and other parameters.

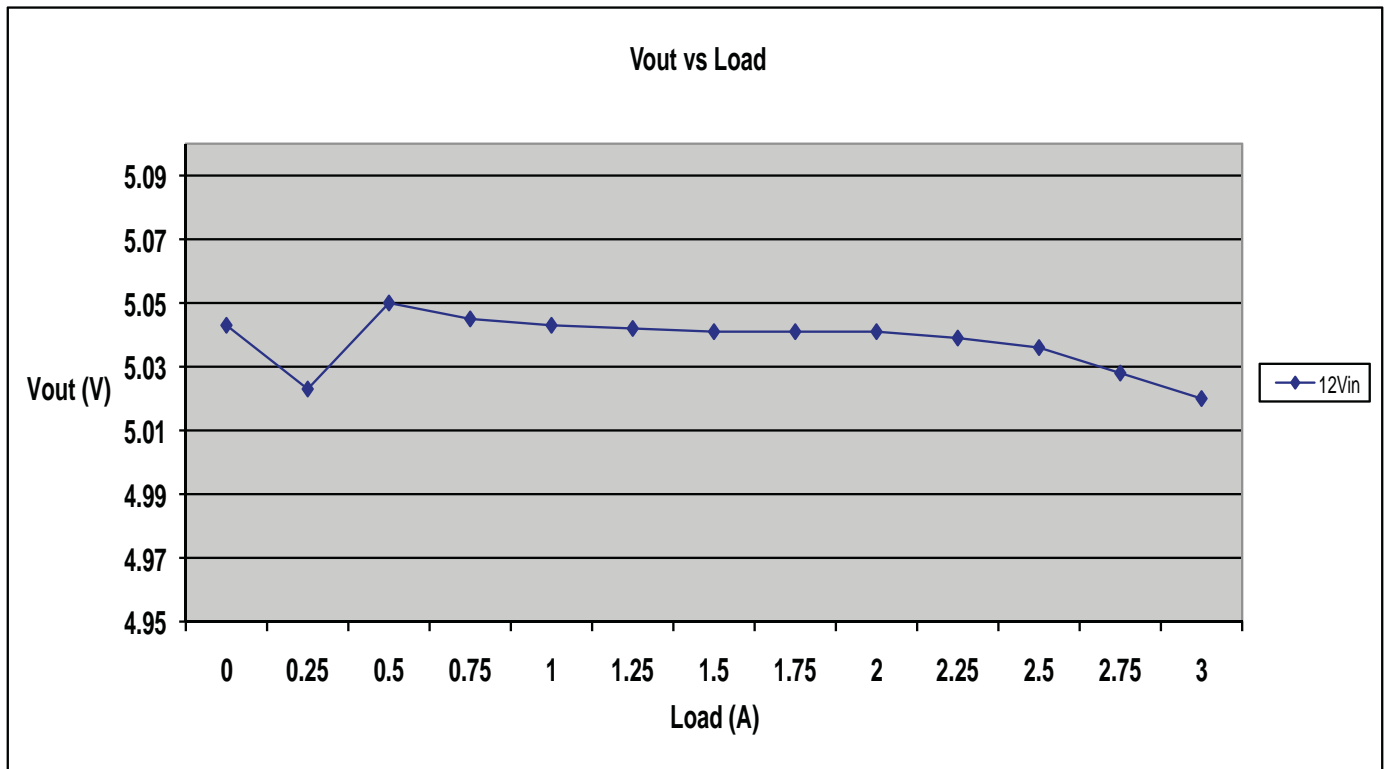

Figure 1. Output Voltage vs Load

QUICK START PROCEDURE

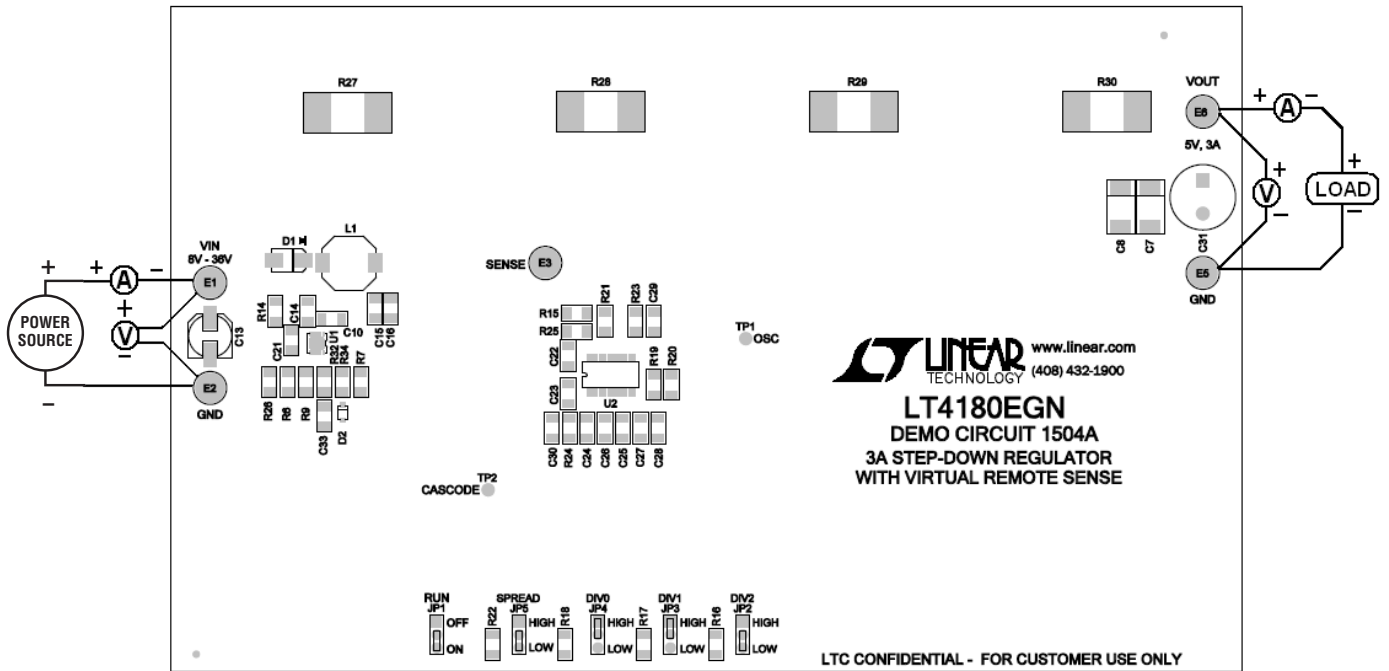

Figure 2. Proper Equipment Setup

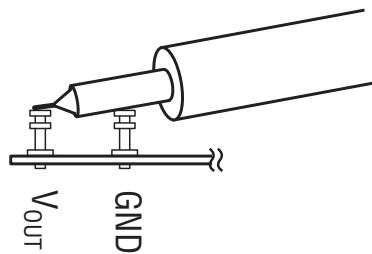

Figure 3. Proper Input/Output Ripple Measurement Technique

DEMO MANUAL DC1504A

PARTS LIST

ITEM	QTY	REFERENCE	PART DESCRIPTION	MANUFACTURER/PART NUMBER
Required Circuit Components for DC1504A				
1	2	C7, C8	CAP, 7343 470µF 20% 10V TANT	AVX TPSE477M010R0050
2	1	C10	CAP, 1206 0.47µF 10% 50V X7R	TDK C3216X7R1H474K
3	1	C13	CAP, 22µF 50V ALUM	SUN ELECT. 50CE22BS
4	1	C14	CAP, 1206 4.7µF 10% 50V X7R	MURATA GRM31CR71H475K
5	2	C15, C16	CAP, 1206 47µF 20% 10V X5R	TAIYO YUDEN LMK316BJ476ML
6	1	C21	CAP, 1206 0.1µF 10% 50V X7R	AVX 12065C104KAT2A
7	2	C22, C23	CAP, 1206 1µF 20% 50V X7R	TDK C3216X7R1H105M
8	1	C24	CAP, 1206 4.7nF 5% 100V C0G	MURATA GRM3195C2A472JA01D
9	2	C25, C27	CAP, 1206 470pF 5% 100V NP0	AVX 12061A471JAT2A
10	2	C26, C28	CAP, 1206 0.047µF 5% 50V X7R	AVX 12065C473JAT
11	1	C29	CAP, 1206 330pF 5% 100V NP0	AVX 12061A331JAT2A
12	1	C30	CAP, 1206 47pF 10% 50V NP0	AVX 12065A470KAT
15	1	D1	DIODE, SCHOTTKY BARRIER RECTIFIER	ON SEMI MBRA340T3G
16	1	D2	DIODE, SCHOTTKY SOD323	CENTRAL SEMI. CMDSH-3 TR
20	1	L1	IND, 6.8H	SUMIDA CDRH8D43-6R8NC
22	1	R6	RES, 1206 10kΩ 1% 1/4W	NIC NRC12F1002TRF
23	1	R7	RES, 1206 68.1kΩ 1% 1/4W	NIC NRC12F6812TRF
24	1	R9	RES, 1206 30.1kΩ 1% 1/4W	NIC NRC12F3012TRF
26	1	R15	RES, 1206 21.5kΩ 1% 1/4W	NIC NRC12F2152TRF
27	1	R19	RES, 1206 1.87kΩ 1% 1/4W	NIC NRC12F1871TRF
28	1	R20	RES, 1206 2.15kΩ 1% 1/4W	NIC NRC12F2151TRF
29	1	R21	RES, 1206 5.36kΩ 1% 1/4W	NIC NRC12F5361TRF
30	1	R23	RES, 1206 22.1kΩ 1% 1/4W	NIC NRC12F2212TRF
31	1	R24	RES, 1206 23.2kΩ 1% 1/4W	VISHAY CRCW120623K2FKEA
32	1	R25	RES, 1206 0.033 Ω 1% 1/4W	VISHAY WSL1206R0330FEA
36	1	R34	RES, 1206 1kΩ 5% 1/4W	VISHAY CRCW12061K00JNEA
37	1	U1	IC, STEP-DOWN SWITCHING REGULATOR	LINEAR TECH. LT3693EDD
38	1	U2	IC,	LINEAR TECH. LT4180EGN
Additional Circuit Components for Demo Board Only				
25	5	R14, R16, R17, R18, R22	RES, 1206 100kΩ 5% 1/4W	VISHAY CRCW1206100KJNEA
34	4	R27, R28, R29, R30	RES, 4527 0.1Ω 5% 2W	VISHAY WSR2R1000JEA
33	1	R26	RES, 1206 0Ω JUMPER	NIC NRC12Z0
Optional Components				
13	0	C31 OPTION	CAP, 470µF 35V ALUM OPTION	SUN ELECT. 35ME470AX
14	0	C33, C34, C35, C36	CAP, 1206 OPTION	OPTION
17	0	D3	DIODE, SCHOTTKY SOD323 OPTION	CENTRAL SEMI. CMDSH-3 OPTION
21	0	Q1	XSTR, 2N7002 N-CHANNEL MOSFET	DIODES/ZETEX 2N7002 OPTION
35	0	R32, R33, R35	RES, 1206 OPTION	OPTION
39	0	U3	IC, DUAL SCHMITT-TRIGGER INVERTER OPTION	TI SN74LVC2G14DBVT OPTION
Hardware for Demo Board Only				
18	5	E1, E2, E3, E5, E6	TURRET	MILL-MAX 2501-2-00-80-00-00-07-0
19	5	JP1, JP2, JP3, JP4, JP5	HEADER, 3-PIN 2mm	SAMTEC TMM-103-02-L-S
40	5	JP1, JP2, JP3, JP4, JP5	SHUNT	SAMTEC 2SN-BK-G

dc1504af

SCHEMATIC DIAGRAM

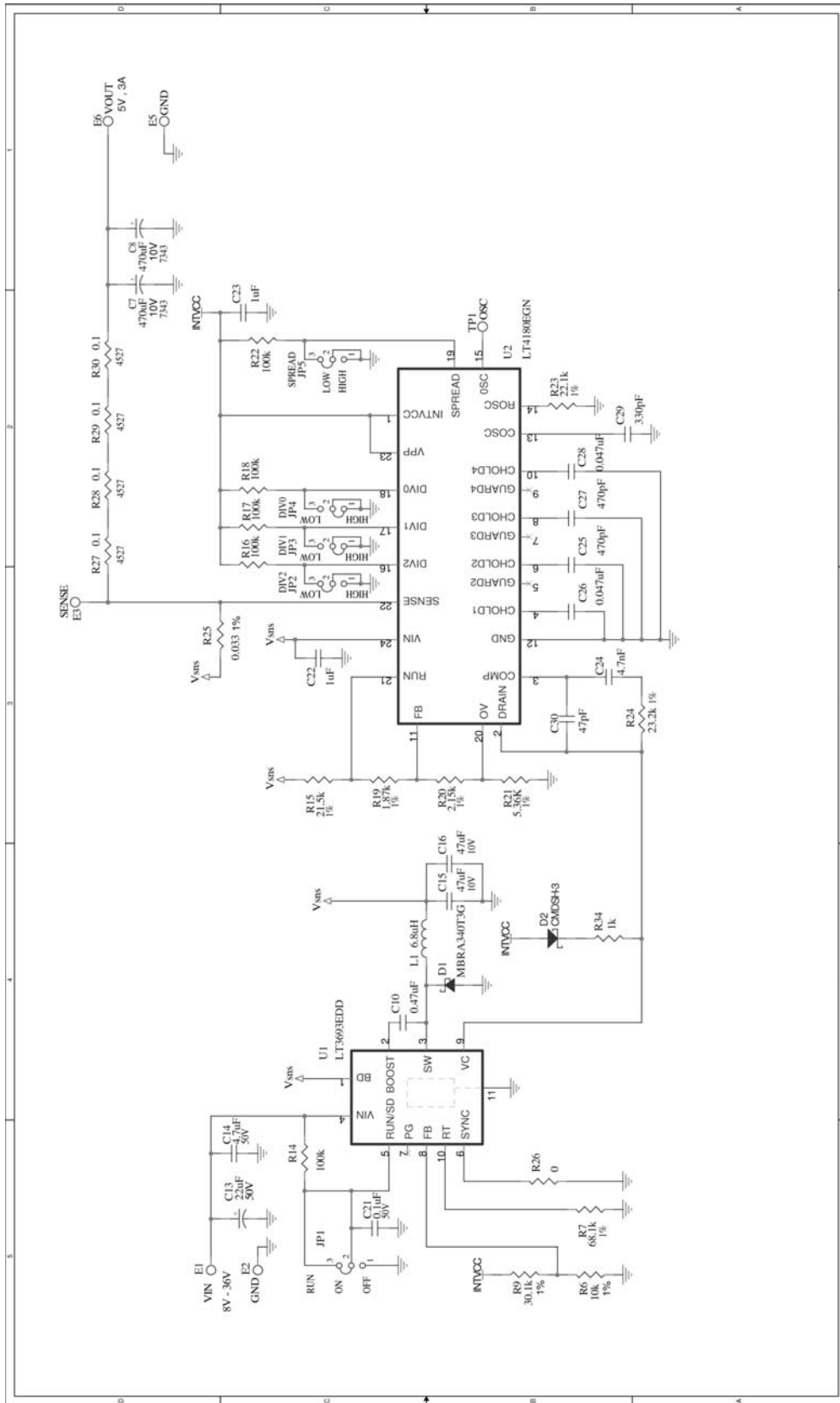

DEMO MANUAL DC1504A

DEMONSTRATION BOARD IMPORTANT NOTICE

Linear Technology Corporation (LTC) provides the enclosed product(s) under the following **AS IS** conditions:

This demonstration board (DEMO BOARD) kit being sold or provided by Linear Technology is intended for use for **ENGINEERING DEVELOPMENT OR EVALUATION PURPOSES ONLY** and is not provided by LTC for commercial use. As such, the DEMO BOARD herein may not be complete in terms of required design-, marketing-, and/or manufacturing-related protective considerations, including but not limited to product safety measures typically found in finished commercial goods. As a prototype, this product does not fall within the scope of the European Union directive on electromagnetic compatibility and therefore may or may not meet the technical requirements of the directive, or other regulations.

If this evaluation kit does not meet the specifications recited in the DEMO BOARD manual the kit may be returned within 30 days from the date of delivery for a full refund. **THE FOREGOING WARRANTY IS THE EXCLUSIVE WARRANTY MADE BY THE SELLER TO BUYER AND IS IN LIEU OF ALL OTHER WARRANTIES, EXPRESSED, IMPLIED, OR STATUTORY, INCLUDING ANY WARRANTY OF MERCHANTABILITY OR FITNESS FOR ANY PARTICULAR PURPOSE. EXCEPT TO THE EXTENT OF THIS INDEMNITY, NEITHER PARTY SHALL BE LIABLE TO THE OTHER FOR ANY INDIRECT, SPECIAL, INCIDENTAL, OR CONSEQUENTIAL DAMAGES.**

The user assumes all responsibility and liability for proper and safe handling of the goods. Further, the user releases LTC from all claims arising from the handling or use of the goods. Due to the open construction of the product, it is the user's responsibility to take any and all appropriate precautions with regard to electrostatic discharge. Also be aware that the products herein may not be regulatory compliant or agency certified (FCC, UL, CE, etc.).

No License is granted under any patent right or other intellectual property whatsoever. **LTC assumes no liability for applications assistance, customer product design, software performance, or infringement of patents or any other intellectual property rights of any kind.**

LTC currently services a variety of customers for products around the world, and therefore this transaction **is not exclusive**.

Please read the DEMO BOARD manual prior to handling the product. Persons handling this product must have electronics training and observe good laboratory practice standards. **Common sense is encouraged.**

This notice contains important safety information about temperatures and voltages. For further safety concerns, please contact a LTC application engineer.

Mailing Address:

Linear Technology
1630 McCarthy Blvd.
Milpitas, CA 95035

Copyright © 2004, Linear Technology Corporation

X-ON Electronics

Largest Supplier of Electrical and Electronic Components

Click to view similar products for [Power Management IC Development Tools](#) category:

Click to view products by [Analog Devices](#) manufacturer:

Other Similar products are found below :

[EVAL-ADM1168LQEBZ](#) [EVB-EP5348UI](#) [MIC23451-AAAYFL EV](#) [MIC5281YMME EV](#) [DA9063-EVAL](#) [ADP122-3.3-EVALZ](#) [ADP130-0.8-EVALZ](#) [ADP130-1.2-EVALZ](#) [ADP130-1.5-EVALZ](#) [ADP130-1.8-EVALZ](#) [ADP1714-3.3-EVALZ](#) [ADP1716-2.5-EVALZ](#) [ADP1740-1.5-EVALZ](#) [ADP1752-1.5-EVALZ](#) [ADP1828LC-EVALZ](#) [ADP1870-0.3-EVALZ](#) [ADP1871-0.6-EVALZ](#) [ADP1873-0.6-EVALZ](#) [ADP1874-0.3-EVALZ](#) [ADP1882-1.0-EVALZ](#) [ADP199CB-EVALZ](#) [ADP2102-1.25-EVALZ](#) [ADP2102-1.875EVALZ](#) [ADP2102-1.8-EVALZ](#) [ADP2102-2-EVALZ](#) [ADP2102-3-EVALZ](#) [ADP2102-4-EVALZ](#) [ADP2106-1.8-EVALZ](#) [ADP2147CB-110EVALZ](#) [AS3606-DB](#) [BQ24010EVM](#) [BQ24075TEVM](#) [BQ24155EVM](#) [BQ24157EVM-697](#) [BQ24160EVM-742](#) [BQ24296MEVM-655](#) [BQ25010EVM](#) [BQ3055EVM](#) [NCV891330PD50GEVB](#) [ISLUSBI2CKIT1Z](#) [LM2744EVAL](#) [LM2854EVAL](#) [LM3658SD-AEV/NOPB](#) [LM3658SDEV/NOPB](#) [LM3691TL-1.8EV/NOPB](#) [LM4510SDEV/NOPB](#) [LM5033SD-EVAL](#) [LP38512TS-1.8EV](#) [EVAL-ADM1186-1MBZ](#) [EVAL-ADM1186-2MBZ](#)