

DESCRIPTION

Demonstration circuit 1521A is a high voltage monolithic LED driver with an integrated 3.3A, 84V power switch. The demonstration circuit is assembled as a boost topology from 6V-80V* input and up to 67V LED output at 370mA (*VIN must not exceed VLED for proper operation). DC1521A features PWM dimming, analog dimming, shutdown, undervoltage lockout, an open LED status pin, and open LED overvoltage protection. Efficiency at 12VIN is as high as 94% for 67VLED at 370mA output.

The switching frequency is set at 375kHz although the range for the IC is 100kHz to 1MHz. The $\overline{\text{VMODE}}$ pin/terminal provides an output flag in case the LEDs are detached from the circuit. EN/UVLO provides undervoltage lockout with hysteresis and a shutdown function that is used by simply tying the pin/terminal to GND. CTRL provides analog dimming by simply pulling the pin/terminal low or by reducing VIN below 11V. Analog dimming with low VIN is changed or removed by changing the values of the EN/UVLO resistors that are used. PWM dimming changes the brightness of the LEDs without changing the LED current. A PWM dimming pulse can be tied to the PWM pin/terminal. If PWM is not used, the pin must still be pulled high and it can be attached to INTVCC or another source.

DC1521A PWM dimming is simple. The boost topology LED string returns to the LED- terminal and the PWM dimming MOSFET between LED- and PGND turns the LED string on and off given an input to the

PWM dimming terminal. For the highest pwm dimming ratio, it is recommended to use 100Hz as a pwm dimming frequency. Information regarding PWM dimming ratios and performance can be found in the LT3956 datasheet in the applications section.

Soft-start is provided with a simple and small capacitor to maintain control of the switch current during turn on for high power designs.

Modifications can be made to the DC1521A in order to convert the board from a boost topology LED driver to any other topology. Buck-boost mode, buck mode, and SEPIC schematics are provided in the datasheet. Please consult the factory or LT3956 datasheet for details regarding how to customize the DC1521A or how to design different topologies for custom specifications.

The LT3956 datasheet gives a complete description of the part, operation and applications information. The datasheet must be read in conjunction with this Quick Start Guide for demonstration circuit 1521A. The LT3956 is assembled in a 36-lead plastic UHE package with two thermally enhanced pads for SW and GND. Proper board layout is essential for both proper operation and maximum thermal performance. See the datasheet section 'Layout Considerations'.

Design files for this circuit board are available. Call the LTC factory.

LT is a trademark of Linear Technology Corporation

PERFORMANCE SUMMARY Specifications are at TA=25°C

PARAMETER	CONDITION	VALUE TYPICAL
Input Voltage VIN Range	Operating	6V to VLED (see text)
LED String Voltage Range	Operating	VIN < VLED < 67V
Switching Frequency	R1 = 28.7k	375kHz
ILED	11V < VIN < VLED	370mA
Maximum Output Voltage - Open LED Voltage		78.4V
Efficiency	VIN=12V VLED=67V ILED=370mA	94%
VMODE	VIN=12V VLED=67V ILED=370mA VIN=12V OPEN LED VOUT=78V	7.1V 0V
Undervoltage Lockout		5.5V UVLO w/ 6V rising turn-on
Peak Switch Current Limit	Minimum IC Rating	3.3A
UVLO	Undervoltage Lockout	VIN Rising, 0°C < TA < 85°C VIN Rising VIN Falling

QUICK START PROCEDURE

Demonstration circuit 1521A is easy to set up to evaluate the performance of the LT3956. Follow the procedure below:

NOTE. Make sure that the VIN DC input voltage does not exceed 80V or the LED string voltage at 370mA. Start with all power supplies turned off.

1. Connect a string of LEDs with forward voltage less than 68V (when running at 370mA) to the LED+ and LED- terminals on the PCB as shown in Figure 1.
2. Connect the EN/UVLO terminal to GND.
3. With power off, connect the VIN power supply to the PVIN (or VIN) and GND terminals. Make sure that the power setting on the supply is not set above 80V or above the expected LED string voltage before the supply is tied to VIN and turned on.
4. Connect 5V or a 5V PWM waveform to the PWM terminal. If PWM is not used, connect PWM to a 5V source or to IntVcc by stuffing a zero ohm resistor in R14 on the PCB. PWM must be pulled high for the LEDs to run.
5. Turn the VIN power supply on.
6. Release the connection between EN/UVLO and GND.
7. Observe the LED string running at the programmed LED current.
8. For PWM dimming, connect a PWM 100Hz or higher signal to the PWM terminal and observe the reduction of brightness in the LED string related to the PWM dimming duty cycle.

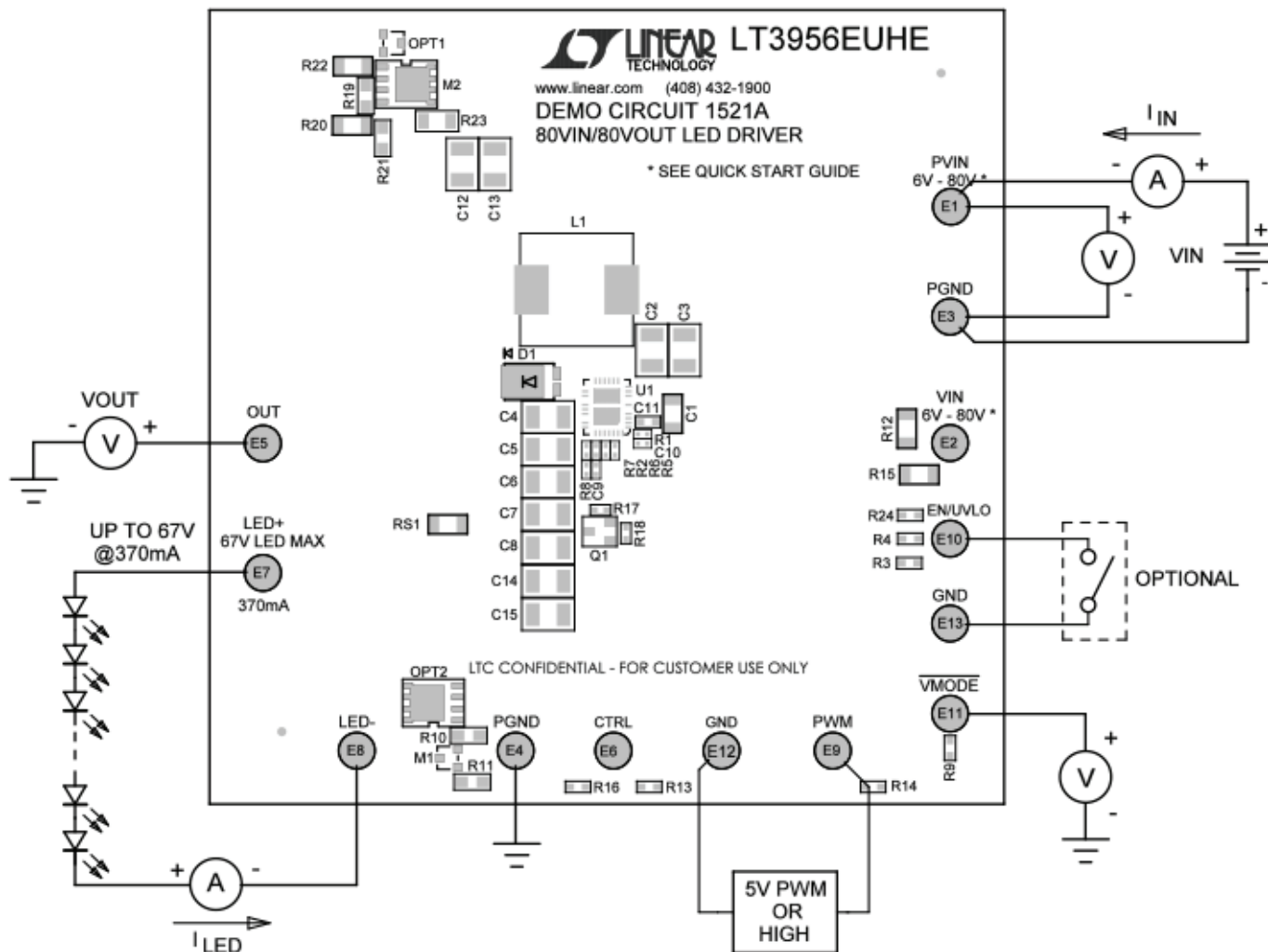

Figure 1. Proper Measurement Equipment Setup

TERMINAL OPTIONS

DC1521A has both **PVIN** and **VIN** terminals. The schematic shows that the PVIN and VIN terminals are shorted together with a resistor R12. With R12 in place, power can be supplied to either PVIN or VIN in order to run the circuit as a boost. The VIN range of 6V to 80V is the operational range of the IC. However, for proper operation, the input voltage should not exceed the LED string voltage since this would cause excessive load currents in a boost. If the board is re-configured as a different topology, R12 can be removed and the VIN terminal and pin can be powered from a separate source or tied to a different input.

The **OUT** terminal is available for the customer to monitor the state of the output capacitor directly. The OUT terminal can also be used as an input for buck mode topology. In general, OUT is 250mV higher than the VLED string voltage when the LEDs are running at full power.

The **PWM** terminal must be pulled high in order for the board to operate. It is preferred that the PWM terminal/pin is tied to IntVcc of the LT3956 by placing a zero ohm resistor in R14 if PWM dimming is not used. For board evaluation it can be tied to an external 5V source as well.

LT3956

The **CTRL** terminal is used for analog dimming. The CTRL terminal and pin voltage directly determine the amount of LED current that is driven. If CTRL is pulled high, the LED string runs at full 370mA current. However, if the CTRL pin voltage is pulled low, the LED current is reduced. Resistors R5 and R6 reduce the LED current if PVIN drops below 11V. This keeps the peak switch current from reaching the IC's internally programmed limit.

The **EN/UVLO** terminal is used to shut down the demonstration circuit. Tie the terminal to GND and the converter stops switching, the PWMOUT pin goes low and the PWM dimming MOSFET is turned off. As long as the PWM dimming MOSFET is used properly, the LEDs do not turn on during shutdown. Resistors R3 and R4 set the undervoltage lockout level and the rising turn-on level of the LT3956. If used in buck mode, the OUT terminal can be connected to VIN through a resistive short and can become the power input terminal for that topology.

$\overline{\text{VMODE}}$ indicates that the circuit is running and that the LED string has been removed from the terminals.

$\overline{\text{VMODE}}$ is pulled up to INTVCC as assembled, but can be pulled up to another source if desired. When used as a constant voltage regulator, $\overline{\text{VMODE}}$ can indicate that the output is in voltage regulation as opposed to constant current regulation.

There are both **GND** and **PGND** terminals on the circuit. The GND terminals are considered to be local signal ground and should not be connected to power input. The PGND terminals can be connected to power inputs and outputs if needed. If diagnostics are connected to GND terminals to measure signal waveforms or voltages make sure that long ground loops are not introduced that will allow PGND currents to run through the GND plane. The layout of the PCB with separate GND and PGND planes is very important to proper operation of the IC. Note that pin 12 (PGND) is not connected to the other PGND pins externally, but that it is tied to GND to create a star ground for the circuit. All of the PGND pins are connected together internally in the IC.

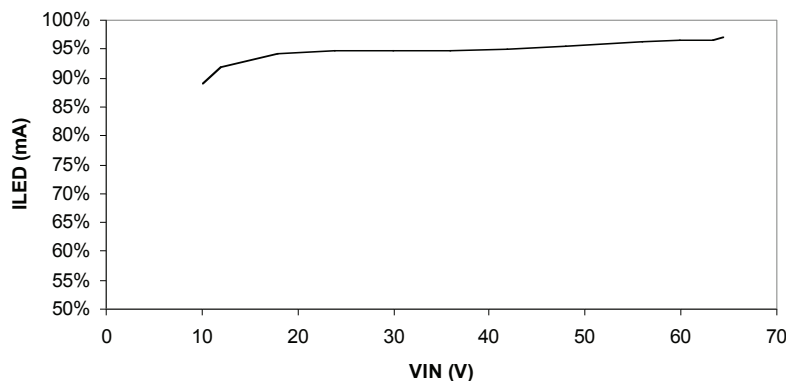

Figure 2. DC1521A Efficiency with 67V LEDs at 370mA

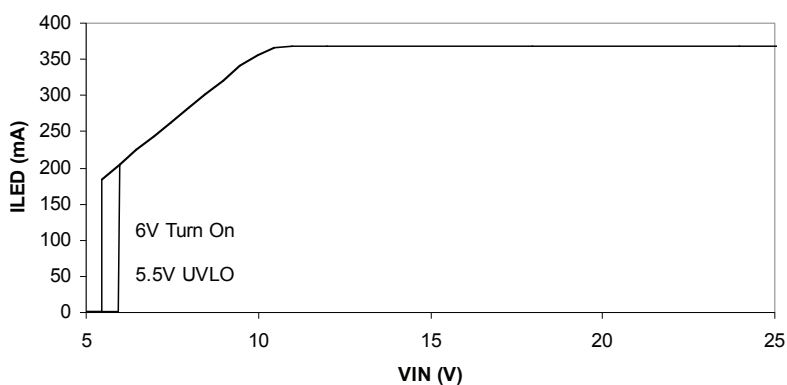

Figure 3. DC1521A LED Current Drops at Low VIN (CTRL) and Turns Off at Lower VIN (UVLO)

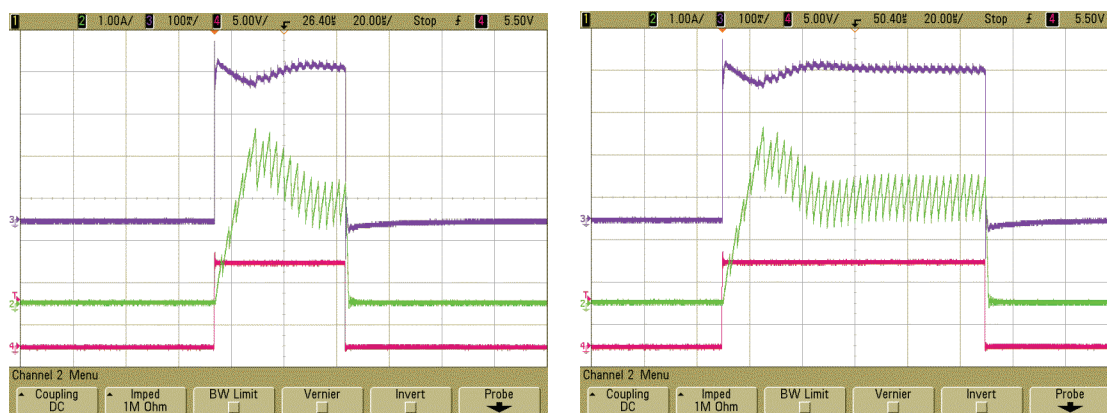

Figure 4. DC1521A 11VIN 67VLED 370mA 100Hz PWM Dimming waveforms 200:1 (left) 100:1 (right). ILED (violet), IL1 (green), PWM (red)

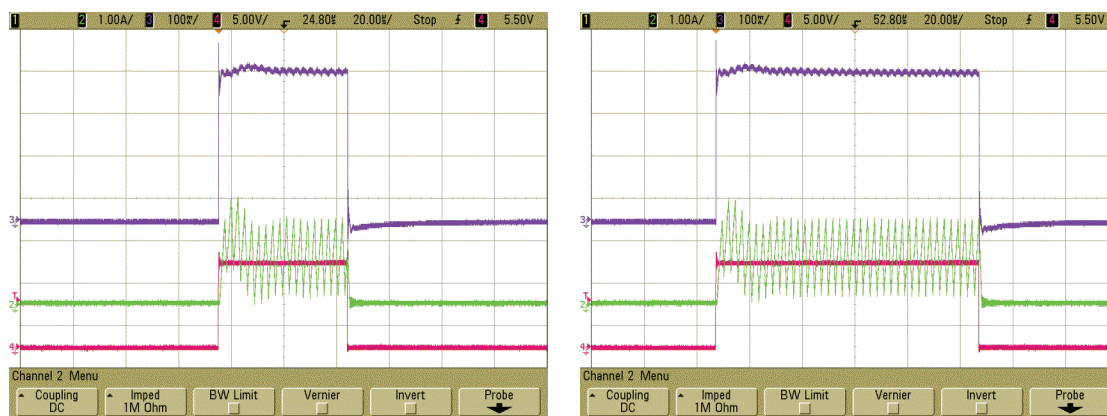
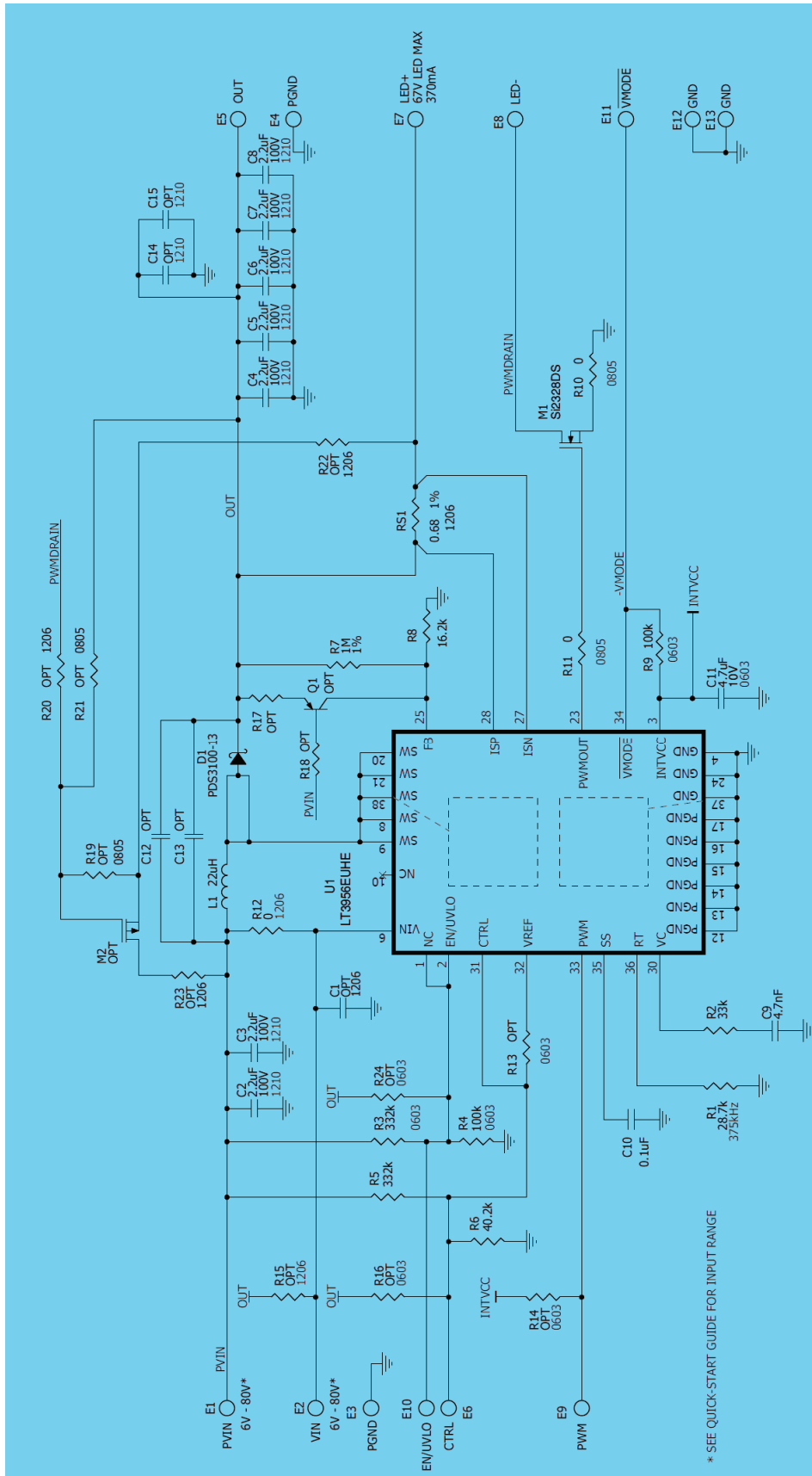

Figure 5. DC1521A 24VIN 67VLED 370mA 100Hz PWM Dimming waveforms 200:1 (left) 100:1 (right). ILED (violet), IL1 (green), PWM (red)



X-ON Electronics

Largest Supplier of Electrical and Electronic Components

Click to view similar products for [LED Lighting Development Tools](#) category:

Click to view products by [Analog Devices](#) manufacturer:

Other Similar products are found below :

[MIC2870YFT EV](#) [ADP8860DBCP-EVALZ](#) [LM3404MREVAL](#) [ADM8843EB-EVALZ](#) [TDGL014](#) [ISL97682IRTZEVALZ](#) [LM3508TLEV](#)
[EA6358NH](#) [MAX16826EVKIT](#) [MAX16839EVKIT+](#) [TPS92315EVM-516](#) [MAX1698EVKIT](#) [MAX6956EVKIT+](#) [OM13321,598](#) [DC986A](#)
[DC909A](#) [DC824A](#) [STEVAL-LLL006V1](#) [IS31LT3948-GRLS4-EB](#) [104PW03F](#) [PIM526](#) [PIM527](#) [MAX6946EVKIT+](#) [MAX20070EVKIT#](#)
[MAX20090BEVKIT#](#) [MAX20092EVSYS#](#) [PIM498](#) [AP8800EV1](#) [ZXLD1370/1EV4](#) [MAX6964EVKIT](#) [MAX25240EVKIT#](#)
[MAX25500TEVKITC#](#) [MAX77961BEVKIT06#](#) [1216.1013](#) [TPS61176EVM-566](#) [TPS61197EVM](#) [TPS92001EVM-628](#) [1270](#) [1271.2004](#)
[1272.1030](#) [1273.1010](#) [1278.1010](#) [1279.1002](#) [1279.1001](#) [1282.1000](#) [1293.1900](#) [1293.1800](#) [1293.1700](#) [1293.1500](#) [1293.1100](#)