

# 15V, 2.5A Synchronous Buck-Boost DC/DC Converter

## DESCRIPTION

Demonstration Circuit 1598A is a fixed frequency synchronous buck-boost converter with an extended input and output range. The unique 4-switch, single inductor architecture provides low noise and seamless operation from input voltages above, below, or equal to the output voltage.

The LTC3112 features selectable PWM or Burst Mode operation, and an easily synchronizable oscillator. An output current monitor allows the load current to be controlled or monitored.

The LTC3112 operates with a 2.7V to 15V input voltage range and a VOUT range from 2.5V to 14V. The

demonstration board has been designed to operate with VIN from 2.7V to 15V and an output current up to 2.5A. For VIN < 5V, IOU capability is reduced. VOUT is set to 5.0V. Typical demo board efficiency is shown below.

**Design files for this circuit board are available. Call the LTC factory.**

LTC, LTM, LT, Burst Mode, are registered trademarks of Linear Technology Corporation. All other trademarks are the property of their respective owners.

Input Voltage Range: VCC	2.7V to 15.0V
VOUT	5.0V
IOU	2.5A for VIN > 5.0V

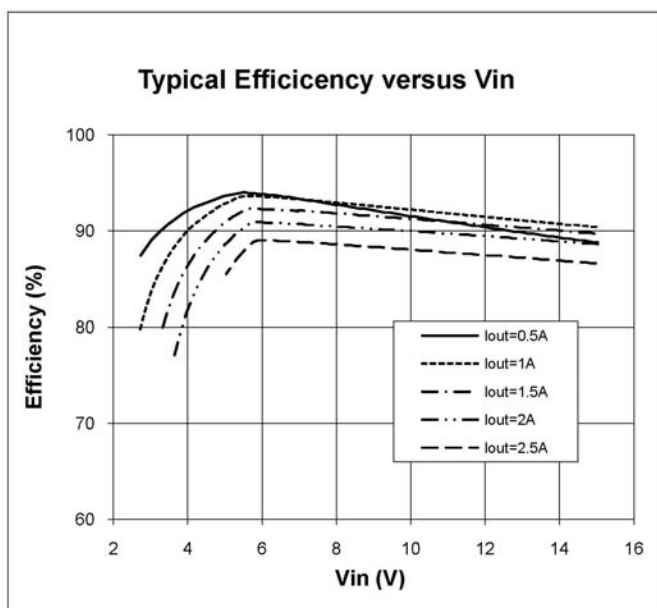

Figure 1. Typical Efficiency

## QUICK START PROCEDURE

Using short twisted pair leads for any power connections and with all loads and power supplies off, refer to Figure 1 for the proper measurement and equipment setup. The Battery/Power Supply (PS1) should not be connected to the circuit until told to do so in the procedure below.

When measuring the input or output voltage ripple, care must be taken to avoid a long ground lead on the oscilloscope probe.

1. Jumper, PS1 and LOAD Settings to start:  
PS1= OFF  
JP1 (RUN) = OFF  
JP2 (PWM) = 750kHz (FIXED FREQUENCY)  
LOAD = 1.0A / 5  $\Omega$  10W resistor
2. With power OFF connect the power supply (PS1) as shown in Figure 1. If accurate current measurements are desired (for efficiency calculations for example) then connect an ammeter in series with the supply as shown. The ammeter is not required however.
3. Connect the load to VOUT as shown in Figure 1. Again, connect an ammeter if accurate current measurement or monitoring is desired.
4. Turn on PS1 and slowly increase voltage until the voltage at VIN is 3.6V. Move Jumper JP1 to ON.
5. Verify VOUT is ~5.0V.
6. VIN can now be varied between 2.7V and 15.0V. VOUT should remain in regulation.
7. IOUT can also be varied from 0 to 2.5A. For VIN < 5.0V, maximum IOUT is reduced. This reduction is due to I<sub>in</sub> increasing as V<sub>in</sub> decreases. Once the input current limit is reached, VOUT will fall out of regulation.  
**NOTE:** If VOUT drops out of regulation, check to be sure the maximum load has not been exceeded, or that VIN is not below the minimum value (2.7V).
8. For operation in BURST Mode move Jumper JP2 to BURST. IOUT is limited in BURST MODE. See the datasheet for more information.  
**NOTE:** IOUT can be monitored at the IOUT/IADJ terminal. The voltage at the terminal is:  
$$V_{IOUT} = IOUT * 24 * 10^{-6} * 42.2k$$
Where 42.2k Ohms is the value of R9. See the datasheet for more information, including typical curves.

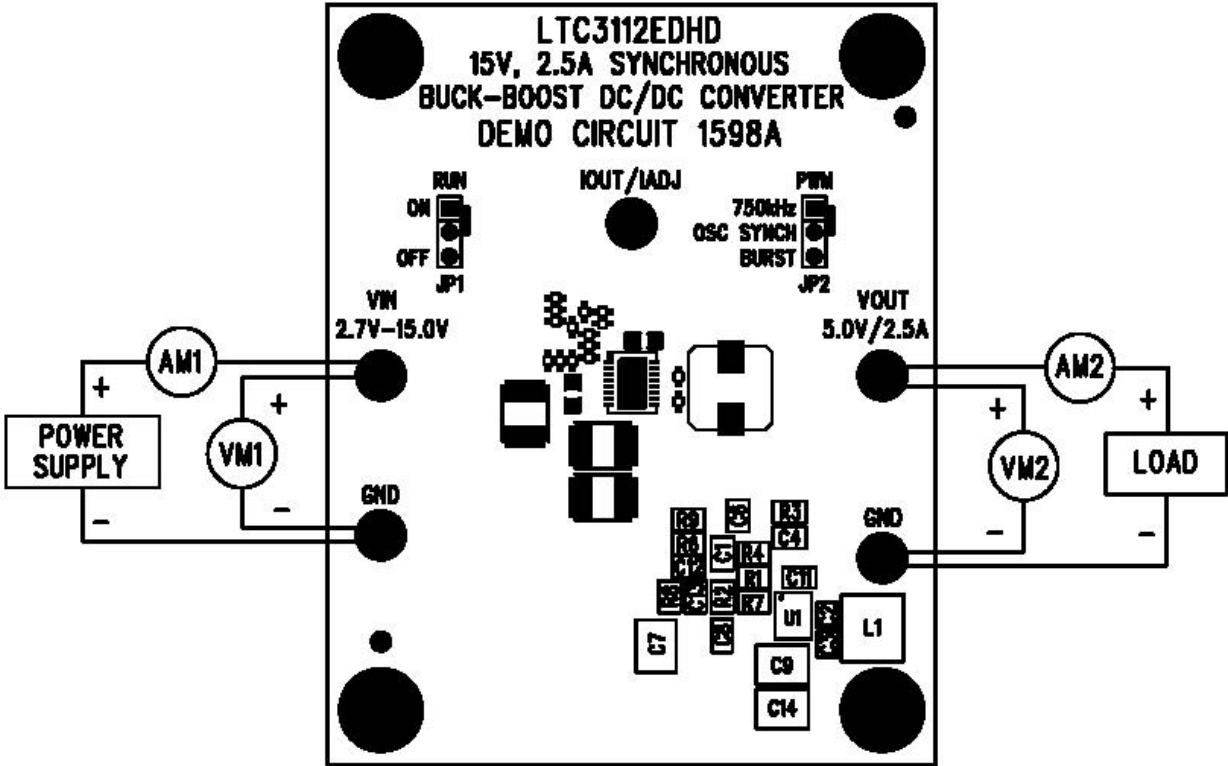

Figure 2. Measurement Setup

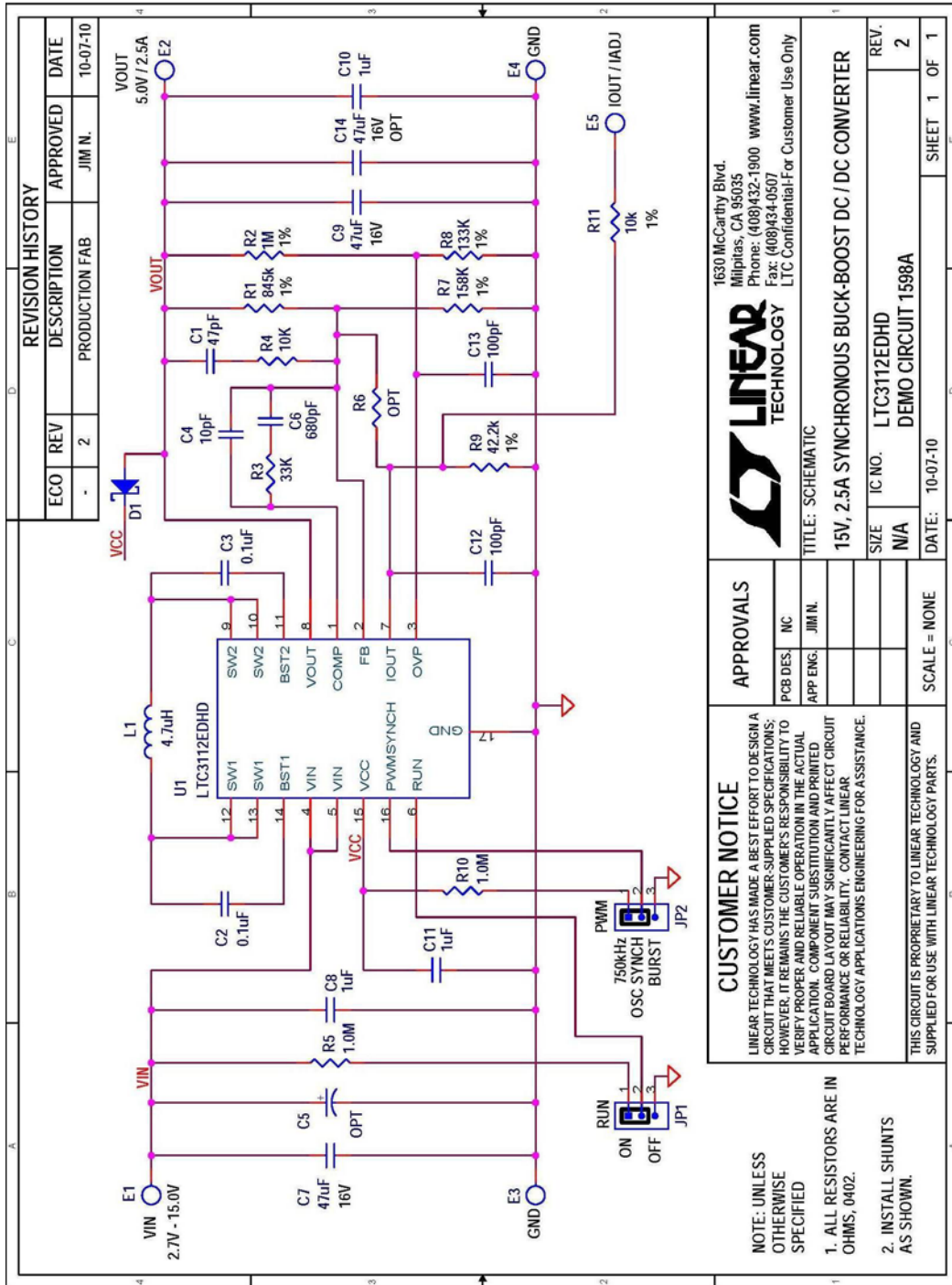

Figure 3. Circuit Schematic

Item	Qty	Reference	Part Description	Manufacturer / Part #
<b>REQUIRED CIRCUIT COMPONENTS:</b>				
1	1	C1	CAP CER 47PF 50V C0G 5% 0402	TDK, C1005C0G1H470J
2	2	C2,C3	CAP CER 0.10UF 16V X7R ±20% 0402	TDK, C1005X7R1C104M
3	1	C4	CAP CER 10PF 50V C0G ±0.5pF 0402	TDK, C1005C0G1H100D
4	1	C6	CAP CER 680PF 50V C0G 0402	MURATA, GRM1555C1H681JA01D
5	2	C9,C7	CAP CERAMIC 47UF 16V X5R ±10% 1210	MURATA, GRM32ER61C476KE15L
6	3	C8,C10,C11	CAP CER 1.0UF 16V X7R 10% 0603	TDK, C1608X7R1C105K
7	2	C12,C13	CAP CER 100pF 50V C0G 5% 0402	TDK, C1005C0G1H101J
8	1	D1	DIODE SCHOTTKY 20V 500MA SOD123	DIODES INC. B0520LW-7-F
9	1	L1	INDUCTOR, 4.7uH	WURTH, 744311470
10	1	R1	RES 845K OHM 1/16W 1% 0402 SMD	PANASONIC, ERJ-2RKF8453X
11	3	R2,R5,R10	RES 1.00M OHM 1/16W 1% 0402 SMD	PANASONIC, ERJ-2RKF1004X
12	1	R3	RES 33.0K OHM 1/10W 1% 0402 SMD	PANASONIC, ERJ-2RKF3302X
13	2	R4,R11	RES 10.0K OHM 1/16W 1% 0402 SMD	PANASONIC, ERJ-2RKF1002X
14	1	R7	RES 158K OHM 1/16W 1% 0402 SMD	PANASONIC, ERJ-2RKF1583X
15	1	R8	RES 133K OHM 1/10W 1% 0402 SMD	PANASONIC, ERJ-2RKF1333X
16	1	R9	RES 42.2K OHM 1/10W 1% 0402 SMD	PANASONIC, ERJ-2RKF4222X
17	1	U1	15V, 2.5A SYNCHRONOUS BUCK-BOOST DC / DC CONVERTER	LINEAR TECH., LTC3112EDHD
<b>ADDITIONAL DEMO BOARD CIRCUIT COMPONENTS:</b>				
1	0	C5 (OPT)	CAP, CAP TANT LOW ESR 47UF 35V 20% SMD	AVX, TPS476K035#0200
2	0	C14 (OPT)	CAP CERAMIC 47UF 16V X5R ±10% 1210	MURATA, GRM32ER61C476KE15L
3	0	R6 (OPT)	RESISTOR, 0402	
<b>HARDWARE-FOR DEMO BOARD ONLY:</b>				
1	5	E1-E5	TURRET, 0.09 DIA	MILL-MAX, 2501-2-00-80-00-00-07-0
2	2	JP1,JP2	JMP, 3PIN 1 ROW .079CC	SAMTEC, TMM-103-02-L-S
3	2	XJP1,XJP2	SHUNT, .079" CENTER	SAMTEC, 2SN-BK-G
4	4	STAND OFF	STAND-OFF, NYLON 0.375" tall	KEYSTONE, 8832 (SNAP ON)

Figure 4. Bill of Materials

## X-ON Electronics

Largest Supplier of Electrical and Electronic Components

*Click to view similar products for [Power Management IC Development Tools](#) category:*

*Click to view products by [Analog Devices](#) manufacturer:*

Other Similar products are found below :

[EVAL-ADM1168LQEBZ](#) [EVB-EP5348UI](#) [MIC23451-AAAYFL EV](#) [MIC5281YMME EV](#) [DA9063-EVAL](#) [ADP122-3.3-EVALZ](#) [ADP130-0.8-EVALZ](#) [ADP130-1.2-EVALZ](#) [ADP130-1.5-EVALZ](#) [ADP130-1.8-EVALZ](#) [ADP1714-3.3-EVALZ](#) [ADP1716-2.5-EVALZ](#) [ADP1740-1.5-EVALZ](#) [ADP1752-1.5-EVALZ](#) [ADP1828LC-EVALZ](#) [ADP1870-0.3-EVALZ](#) [ADP1871-0.6-EVALZ](#) [ADP1873-0.6-EVALZ](#) [ADP1874-0.3-EVALZ](#) [ADP1882-1.0-EVALZ](#) [ADP199CB-EVALZ](#) [ADP2102-1.25-EVALZ](#) [ADP2102-1.875EVALZ](#) [ADP2102-1.8-EVALZ](#) [ADP2102-2-EVALZ](#) [ADP2102-3-EVALZ](#) [ADP2102-4-EVALZ](#) [ADP2106-1.8-EVALZ](#) [ADP2147CB-110EVALZ](#) [AS3606-DB](#) [BQ24010EVM](#) [BQ24075TEVM](#) [BQ24155EVM](#) [BQ24157EVM-697](#) [BQ24160EVM-742](#) [BQ24296MEVM-655](#) [BQ25010EVM](#) [BQ3055EVM](#) [NCV891330PD50GEVB](#) [ISLUSBI2CKIT1Z](#) [LM2744EVAL](#) [LM2854EVAL](#) [LM3658SD-AEV/NOPB](#) [LM3658SDEV/NOPB](#) [LM3691TL-1.8EV/NOPB](#) [LM4510SDEV/NOPB](#) [LM5033SD-EVAL](#) [LP38512TS-1.8EV](#) [EVAL-ADM1186-1MBZ](#) [EVAL-ADM1186-2MBZ](#)