

LTC5583

DUAL 6GHz RMS POWER DETECTOR

DESCRIPTION

Demonstration circuit 1599A is a Mean-Squared Power Detector featuring the LTC®5583 IC. LTC5583 is a dual-channel RMS power detector, capable of measuring two AC signals. It provides 40dB of channel to channel isolation with no frequency separation at 2140MHz that is suited for measuring VSWR.

The LTC5583 is a wide dynamic range Mean Squared RF Power Detector, operational from 40MHz to 6GHz. The input dynamic range with ± 1 dB nonlinearity is 60dB depending on frequency (from -58 dBm to $+2$ dBm, single-ended 50 Ω input). The detector output voltage slope is normally 30mV/dB, and the typical output variation over temperature is ± 0.5 dB at 880MHz.

The DC1599A Demo Circuit is ideal for frequency operation below 3.0GHz. It has the single ended input drive to LTC5583. The input A to output B (or input B to output A) isolation is 33dB at 2.7GHz, and degrades as input frequency increases. As a result, operating above 3GHz may require differential input matching for improved isolation. Temperature performance is optimized for 2140MHz. Contact LTC applications for more information.

LTC is a trademark of Linear Technology Corporation. Design files for this circuit board are available. Call the LTC factory.

Typical Performance Summary ($V_{CC} = 3.3V$, EN = HIGH, $T_A = 25^\circ C$, unless otherwise noted. Test circuit shown in Figure 1.)

PARAMETER	CONDITION	VALUE
Supply Voltage		3.1V to 3.5V
Supply Current	Envelope detector off	80.5mA
	Envelope detector on	90.1mA
Shutdown Current	EN = Lo	0.1 μ A
EN Voltage	Low, Chip Disabled HIGH, Chip Enabled	0.3V max 2V min
EN Input Current	$V_{EN} = 0V$ $V_{EN} = 3.3V$	0 μ A 100 μ A
Output Start Voltage	No Input Signal Present	0.45V
Rise Time	0.5V to 2.2V, 10% to 90%, $C_{FLTRA}=C_{FLTRB} = 8.2nF$, $F_{RF} = 100$ MHz	140nS
Fall Time	2.2V to 0.5V, 90% to 10%, $C_{FLTRA}=C_{FLTRB} = 8.2nF$, $F_{RF} = 100$ MHz	3.5 μ S
Input Frequency Range	Operation over wider frequency range with reduced performance	40MHz to 6GHz
f = 450MHz		
Linear Dynamic Range	± 1 dB linearity error	63 dB
RF Input Power Range	CW, 50 Ω , ± 1 dB Linearity Error	-59 to 4 dBm
Slope		29.6mV/dB
Logarithmic Intercept		-78.5dBm

Deviation from CW Response	12 dB peak-to-average ratio (4 carrier WCDMA)	0.4
INA to VOB isolation	$P_{INB} = -45\text{dBm}$, $VOB = VOB$ $p_{INB} \pm 1\text{ dB}$, Frequency Separation=0Hz	50dB
INB to VOA isolation	$P_{INA} = -45\text{dBm}$, $VOA = VOA$ $p_{INA} \pm 1\text{ dB}$, Frequency Separation=0Hz	50dB
f =2140MHz		
Linear Dynamic Range	$\pm 1\text{ dB}$ linearity error	60 dB
RF Input Power Range	CW, 50Ω , $\pm 1\text{dB}$ Linearity Error	-58 to 2 dBm
Slope		29.6mV/dB
Logarithmic Intercept		-77.4dBm
Deviation from CW Response	12 dB peak-to-average ratio (4 carrier WCDMA)	0.3
INA to VOB isolation	$P_{INB} = -45\text{dBm}$, $VOB = VOB$ $p_{INB} \pm 1\text{ dB}$, Frequency Separation=0Hz	40dB
INB to VOA isolation	$P_{INA} = -45\text{dBm}$, $VOA = VOA$ $p_{INA} \pm 1\text{ dB}$, Frequency Separation=0Hz	40dB
f =2700MHz		
Linear Dynamic Range	$\pm 1\text{ dB}$ linearity error	59 dB
RF Input Power Range	CW, 50Ω , $\pm 1\text{dB}$ Linearity Error	-56 to 3 dBm
Slope		30mV/dB
Logarithmic Intercept		-74.9dBm
Deviation from CW Response	12 dB peak-to-average ratio (WiMAX OFDM)	0.6dB
INA to VOB isolation	$P_{INB} = -45\text{dBm}$, $VOB = VOB$ $p_{INB} \pm 1\text{ dB}$, Frequency Separation=0Hz	33dB
INB to VOA isolation	$P_{INA} = -45\text{dBm}$, $VOA = VOA$ $p_{INA} \pm 1\text{ dB}$, Frequency Separation=0Hz	33dB

Table 1. Jumper Description

JUMPER	FUNCTION	RANGE/SETTING (DEFAULT)
JP1	Chip Enable. EN for High, DIS for Lo	EN
JP2	VCCN. Power supply to the envelop detector for both channels. HI=on, LO=off	LO
JP3	INV. Swap control for the polarity of VODF. HI=(VOB-VOA)+VOS, LO=(VOA-VOB)+VOS	LO

QUICK START PROCEDURE

Demonstration circuit 1599A is easy to set up to evaluate the performance of the LTC5583. Refer to Figure 1 for measurement equipment setup and follow the procedure below:

1. Connect voltmeter's negative (-) lead to demo board GND test point(TP8 or TP9).
2. Connect voltmeter's positive (+) lead to the demo board VOA(TP2) and VOB(TP5) to measure channel A and channel B output respectively.
3. Connect DC power supply's negative (-) output to demo board GND(TP8 or TP9).
4. Connect DC power supply's positive (+) output (3.1V to 3.5V) to demo board V_{CC} test point(TP7).
 - Do not exceed 3.8V, the absolute maximum supply voltage.**
 - Set VCCN jumper to LO, to turn off the envelope detector if not needed.**
 - Set the Swap jumper to LO for:**
 - VODF= (VOA-VOB)+VOS.**
 - Set swap to HI for:**
 - VODF=(VOB-VOA)+VOS**
5. Connect signal generator's output to demo board INPUT port (SMA connector J1 for channel A input, or J2 for channel B input) via coaxial cable.

6. A 3dB attenuator may be inserted for broadband input match, the detected power range is shifted higher by 3dB.
 7. Set the JP1 to EN to enable the IC. Now the detector is enabled (on) and is ready for measurement.
 8. Apply RF input signal and measure OUTPUT DC voltages at VOA and VOB.
- Do not exceed +18dBm, the absolute maximum RF input power.**

NOTES:

1. The voltage on the EN test point must never exceed $V_{CC} + 0.3V$.
2. For digitally modulated signals, an oscilloscope can be used to observe the AC components of the output.
3. Suggest to set VCCN LO when envelope detector is not used. This will result in lower power consumption.
4. Temperature compensation values for RT1 and RT2 may be different at different frequencies. See table 1 for additional information.

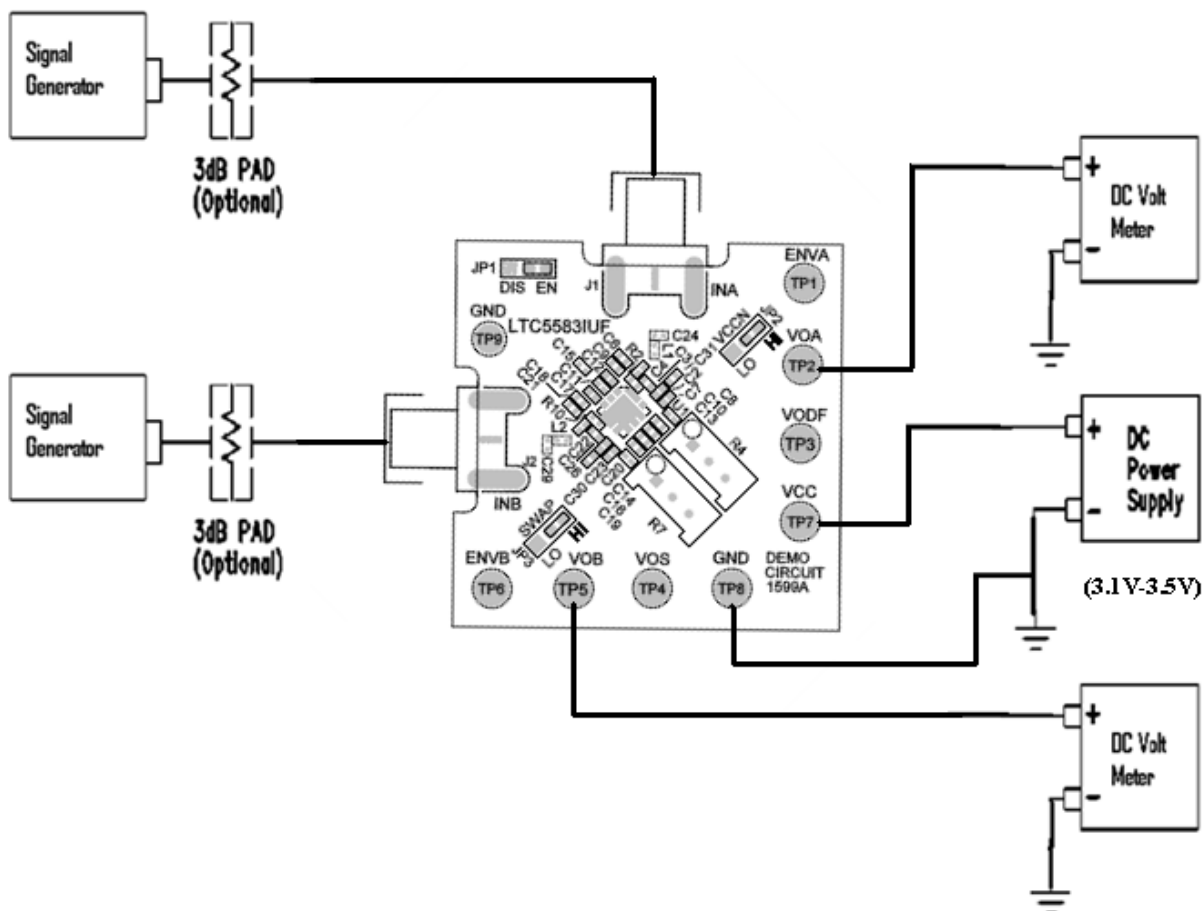
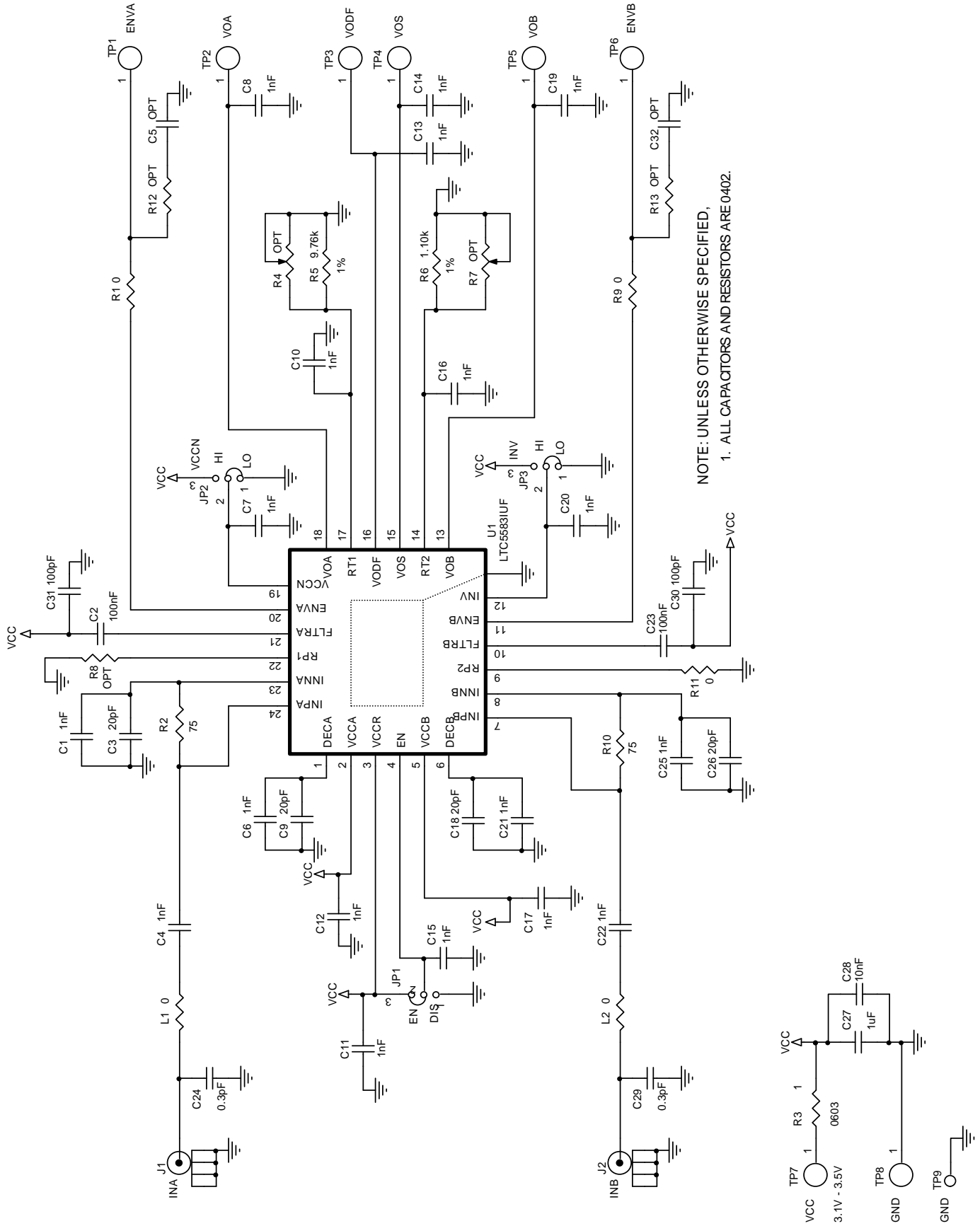

Figure 1. Proper Test Equipment Setup

LTC5583

Frequency (MHz)	RP1 (k Ω)	RP2 (k Ω)	RT1 (k Ω)	RT2 (k Ω)
450	Open	0	11.5	1.13
880	Open	0	11.5	1.13
900	Open	0	11	0.953
1800	Open	0	12.1	1.5
2140	Open	0	9.76	1.1
2300	Open	0	10.5	1.43
2500	Open	0	10.5	1.43
2700	Open	0	8.87	1.21

Table 2. Suggested RT1 and RT2 values for the optimum temperature performance at various RF input frequencies.



LTC5583

Bill of Materials:

DC1599A Rev 2

7/30/2010

SIC

Item	Qty	Ref -Des	Desc	Manufacturer's Part Number
1	18	C1,C4,C6-C8,C10-C17, C19-C22,C25	CAP, 0402 1nF 10% 50V X7R	MURATA GRM155R71H102KA01D
2	2	C2,C23	CAP, 0402 100nF 10% 16V X7R	TAIYO YUDEN EMK105B7104KV-F
3	4	C3,C9,C18,C26	CAP, 0402 20pF 5% 50V C0G	MURATA GRM1555C1H200J01D
4	0	C5,C32	CAP, 0402 OPTION	OPTION
5	2	C24,C29	CAP, 0402 0.3pF +/-0.1pF 50V NPO	MURATA GJM1555C1HR30BB01D
6	1	C27	CAP, 0402 1uF 10% 6.3V X5R	MURATA GRM155R60J105KE19
7	1	C28	CAP, 0402 10nF 10% 16V X7R	MURATA GRM155R71C103KA01D
8	2	C30,C31	CAP, 0402 100pF 5% 50V C0G	MURATA GRM1555C1H101JZ01
9	3	JP1,JP2,JP3	HEADER,3PIN, 2mm	SAMTEC TMM-103-02-L-S
10	2	J1,J2	CONN, BNC, SMA 50-OHM EDGE-LANCH	E.F.JOHNSON, 142-0701-851
11	5	R1,L1,L2,R9,R11	RES, 0402 0 OHM JUMPER	VISHAY CRCW04020000Z0ED
12	2	R2,R10	RES, 0402 75 OHMS 5% 1/16W	VISHAY CRCW040275R0JNED
13	1	R3	RES, 0603 1 OHM 1% 1/10W	VISHAY CRCW06031R00FKEA
14	0	R4,R7	RES, TRIMMING POT OPT	OPTION
15	1	R5	RES, 0402 9.76k OHMS 1% 1/16W	
16	1	R6	RES, 0402 1.10k OHMS 1% 1/16W	
17	0	R12,R13	RES, 0402 OPTION	OPTION
18	8	TP1-TP8	TURRET	MILL-MAX 2501-2-00-80-00-00-07-0
19	1	TP9	TURRET	MILL MAX 2308-2-00-80-00-00-07-0
20	1	U1	IC, DUAL RMS POWER DETECTOR	LINEAR TECH LTC5583IUF
21	3	JP1,JP2,JP3	SHUNT, 2mm	SAMTEC 2SN-BK-G

X-ON Electronics

Largest Supplier of Electrical and Electronic Components

Click to view similar products for [RF Development Tools](#) category:

Click to view products by [Analog Devices](#) manufacturer:

Other Similar products are found below :

[MAAM-011117](#) [MAAP-015036-DIEEV2](#) [EV1HMC1113LP5](#) [EV1HMC6146BLC5A](#) [EV1HMC637ALP5](#) [EVAL-ADG919EBZ](#) [ADL5363-EVALZ](#) [LMV228SDEVAL](#) [SKYA21001-EVB](#) [SMP1331-085-EVB](#) [EV1HMC618ALP3](#) [EVAL01-HMC1041LC4](#) [MAAL-011111-000SMB](#)
[MAAM-009633-001SMB](#) [107712-HMC369LP3](#) [107780-HMC322ALP4](#) [SP000416870](#) [EV1HMC470ALP3](#) [EV1HMC520ALC4](#)
[EV1HMC244AG16](#) [MAX2614EVKIT#](#) [124694-HMC742ALP5](#) [SC20ASATEA-8GB-STD](#) [MAX2837EVKIT+](#) [MAX2612EVKIT#](#)
[MAX2692EVKIT#](#) [EV1HMC629ALP4E](#) [SKY12343-364LF-EVB](#) [108703-HMC452QS16G](#) [EV1HMC863ALC4](#) [EV1HMC427ALP3E](#)
[119197-HMC658LP2](#) [EV1HMC647ALP6](#) [ADL5725-EVALZ](#) [106815-HMC441LM1](#) [EV1HMC1018ALP4](#) [UXN14M9PE](#) [MAX2016EVKIT](#)
[EV1HMC939ALP4](#) [MAX2410EVKIT](#) [MAX2204EVKIT+](#) [EV1HMC8073LP3D](#) [SIMSA868-DKL](#) [SIMSA868C-DKL](#) [SKY65806-636EK1](#)
[SKY68020-11EK1](#) [SKY67159-396EK1](#) [SKY66181-11-EK1](#) [SKY65804-696EK1](#) [SKY13396-397LF-EVB](#)