

LTC3604EUD

2.5A, 15V, MONOLITHIC SYNCHRONOUS STEP-DOWN REGULATOR

DESCRIPTION

Demonstration circuit 1610 is a step-down converter, using the LTC3604 monolithic synchronous buck regulator. The DC1610A has a maximum input voltage 15V, and is capable of delivering up to 2.5A of output current at a minimum input voltage of 3.6V. The output voltage of the DC1610A can be set as low as 0.6V, the reference voltage of the LTC3604. At low load currents, the DC1610A operates in discontinuous mode, and during shutdown, it consumes less than 40 uA of quiescent current. In continuous mode operation, the DC1610A is a high efficiency circuit - over 80%. The

DC1610A can track another voltage with the LTC3604 track function. Because of the high switching frequency of the LTC3604, which is programmable up to 4 MHz, the DC1610A uses low profile surface mount components. All these features make the DC1610A an ideal circuit for use in Lithium-Ion Battery applications and distributed power systems. Gerber files for this circuit are available. Call the LTC Factory.

Design files for this circuit board are available. Call the LTC factory.

As Shipped Performance Summary

| PARAMETER | CONDITIONS | VALUE |
|-------------------------------|---|----------------------------|
| Minimum Input Voltage | | 3.6V |
| Maximum Input Voltage | | 15V |
| Run/Shutdown | | GND = Shutdown |
| | | V _{IN} = Run |
| Output Voltage Regulation | V _{IN} = 3.6V to 15V, I _{OUT} = 0A to 2.5A | 1.2V ±4% (1.152V – 1.248V) |
| | V _{IN} = 3.6V to 15V, I _{OUT} = 0A to 2.5A | 1.8V ±4% (1.728V – 1.872V) |
| | V _{IN} = 4.5V to 15V, I _{OUT} = 0A to 2.5A | 3.3V ±4% (3.168V – 3.432V) |
| Typical Output Ripple Voltage | V _{IN} = 12V, V _{OUT} = 1.8V, I _{OUT} = 2.5A (20 MHz BW) | < 20mV _{P-P} |
| Burst Mode | V _{IN} = 12V, V _{OUT} = 1.8V | < 700 mA |
| Nominal Switching Frequency | R _T = 324k | 1 MHz ± 20% |

Table 1. Jumper Description

| JUMPER | FUNCTION | RANGE/SETTING (DEFAULT) |
|--------|--|---------------------------|
| JP1 | Vout Setting. | 1.2V |
| JP5 | Tracking or Soft-Start (SS) | (SS) - TRACK |
| JP6 | Mode: Forced Continuous Mode (FCM), Burst Mode, or External Synchronization (SYNC) | (FCM) – SYNC – Burst Mode |
| JP7 | Run | (ON) - OFF |
| JP8 | Frequency | (1 MHz) - 2 MHz |
| JP9 | ITH: Compensation | INT – (EXT) |

QUICK START PROCEDURE

Demonstration Circuit 1610 is easy to set up to evaluate the performance of the LTC3604. For proper measurement equipment configuration, set up the circuit according to the diagram in **Figure 1**. Before proceeding to test, insert shunts into the 1.2V position of the output voltage header JP1, into the SS (soft-start) position of Track/SS header JP5, into the FCM (Forced Continuous Mode) position of MODE header JP6, into the OFF position of RUN header JP7, into the 1 MHz position of FREQ header JP8, and into the EXT position of ITH header JP9.

When measuring the input or output voltage ripple, care must be taken to avoid a long ground lead on the oscilloscope probe. Measure the input or output voltage ripple by touching the probe tip directly across the Vin or Vout and GND terminals. See **Figure 2** for proper scope probe measurement technique.

With the DC1610 set up according to the proper measurement configuration and equipment in **Figure 1**, apply 6.3V at Vin (Do not hot-plug Vin or increase Vin over the rated maximum supply voltage of 15V, or the part may be damaged.). Measure Vout; it should read 0V. Turn on the circuit by inserting the shunt in header JP7 into the ON position. The output voltage should be regulating. Measure Vout - it should measure 1.2V +/- 2% (1.176V to 1.224V).

Vary the input voltage from 3.6V to 15V and adjust the load current from 0 to 2.5A. Set the input voltage to 15V and the output current to 2.5A. Measure the output ripple voltage; it should measure less than 20 mVAC.

Observe the voltage waveform at the switch pins (the other side of the inductor from the output). Verify the switching frequency is between 800 kHz and 1.2 MHz ($T = 1.25 \mu\text{s}$ and $0.833 \mu\text{s}$), and that the switch node waveform is rectangular in shape.

Change the JP6 shunt from forced continuous mode to Burst Mode. Also set the input voltage to 12V and the

output current to any current less than 400 mA. Observe the discontinuous mode of operation at the switch node, and measure the output ripple voltage. It should measure less than 150 mV.

Insert the JP7 shunt into the OFF position and move the shunt in the 1.2V output JP1 header into any of the two remaining output voltage option headers: 1.8V (JP2) or 3.3V (JP3). Just as in the 1.2V Vout test, the output voltage should read Vout +/- 2% tolerance under static line and load conditions and +/- 1% tolerance under dynamic line and load conditions (+/- 2% total). Also, the circuit operation in discontinuous mode will be the same.

When finished, turn off the circuit by inserting the shunt in header JP7 into the OFF position.

Low Output Voltage, 2MHz Operation

In applications with low output voltages of less than 1.2V, and frequencies of 2 MHz or higher, the inductor ripple current will be reduced significantly such that the internal current comparator will not be able to clearly differentiate it from surrounding noise. Sporadic ckt. operation will result. To avoid this effect, replace the standard 1 uH inductor with a 0.47 uH inductor. This will make the inductor ripple current large enough so that the circuit operation will not be affected.

Warning - If the power for the demo board is carried in long leads, the input voltage at the part could “ring”, which could affect the operation of the circuit or even exceed the maximum voltage rating of the IC (which, of course, may damage the IC). To eliminate the ringing, a small tantalum capacitor has been inserted on the pads between the input power and return terminals on the bottom of the demo board. The (greater) ESR of the tantalum capacitor will dampen the (possible) ringing voltage due to the use of long input leads. On a normal, typical PCB, with short traces, the capacitor is not needed.

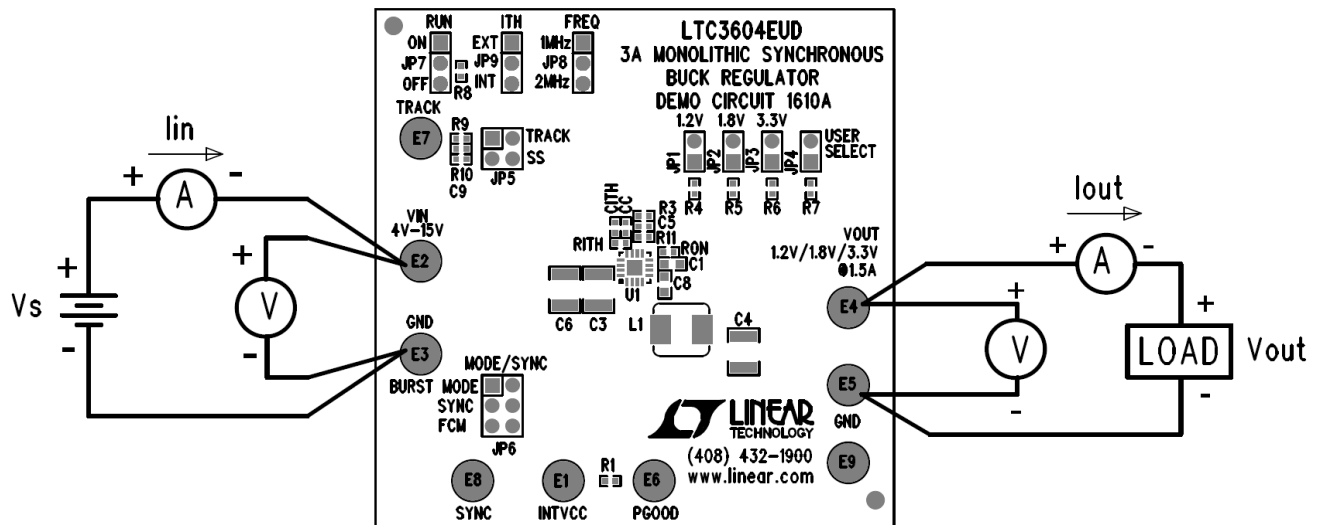

Figure 1. Proper Equipment Measurement Set-Up

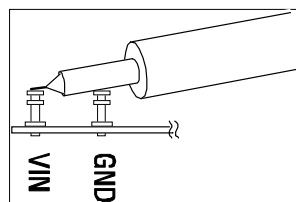

Figure 2. Measuring Input or Output Ripple

Normal Switching Frequency & Output Ripple Voltage Waveforms

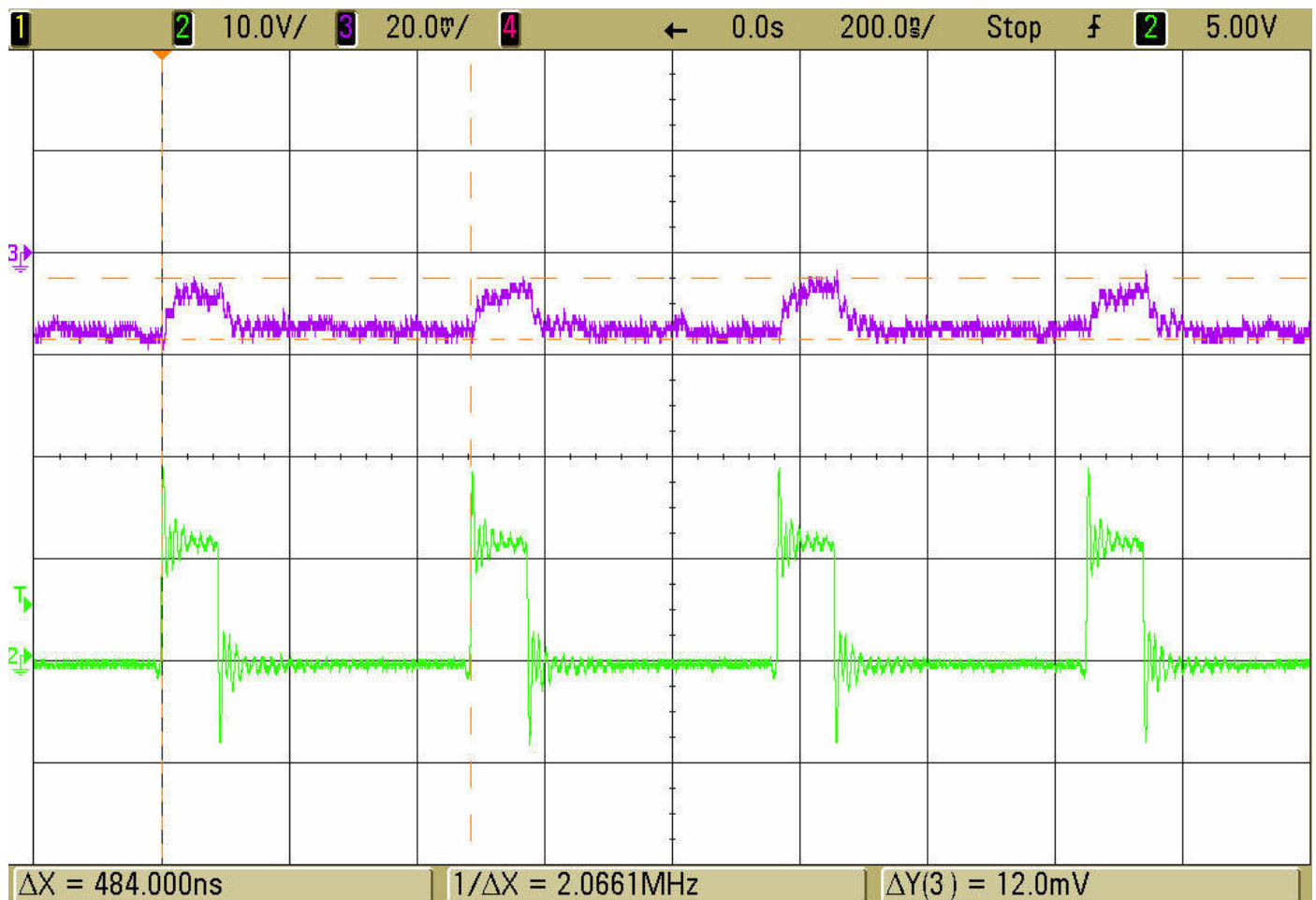

Figure 3. Switch Node & Output Ripple Voltage Waveforms

$V_{\text{IN}} = 12\text{V}$, $V_{\text{OUT}} = 1.8\text{V}$, $I_{\text{OUT}} = 2.5\text{A}$, $F_{\text{SW}} = 2\text{MHz}$

Trace 3: Output Ripple Voltage (20 mV/div AC)

Trace 2: Switch Voltage (10 V/div)

Load Step Response Waveform

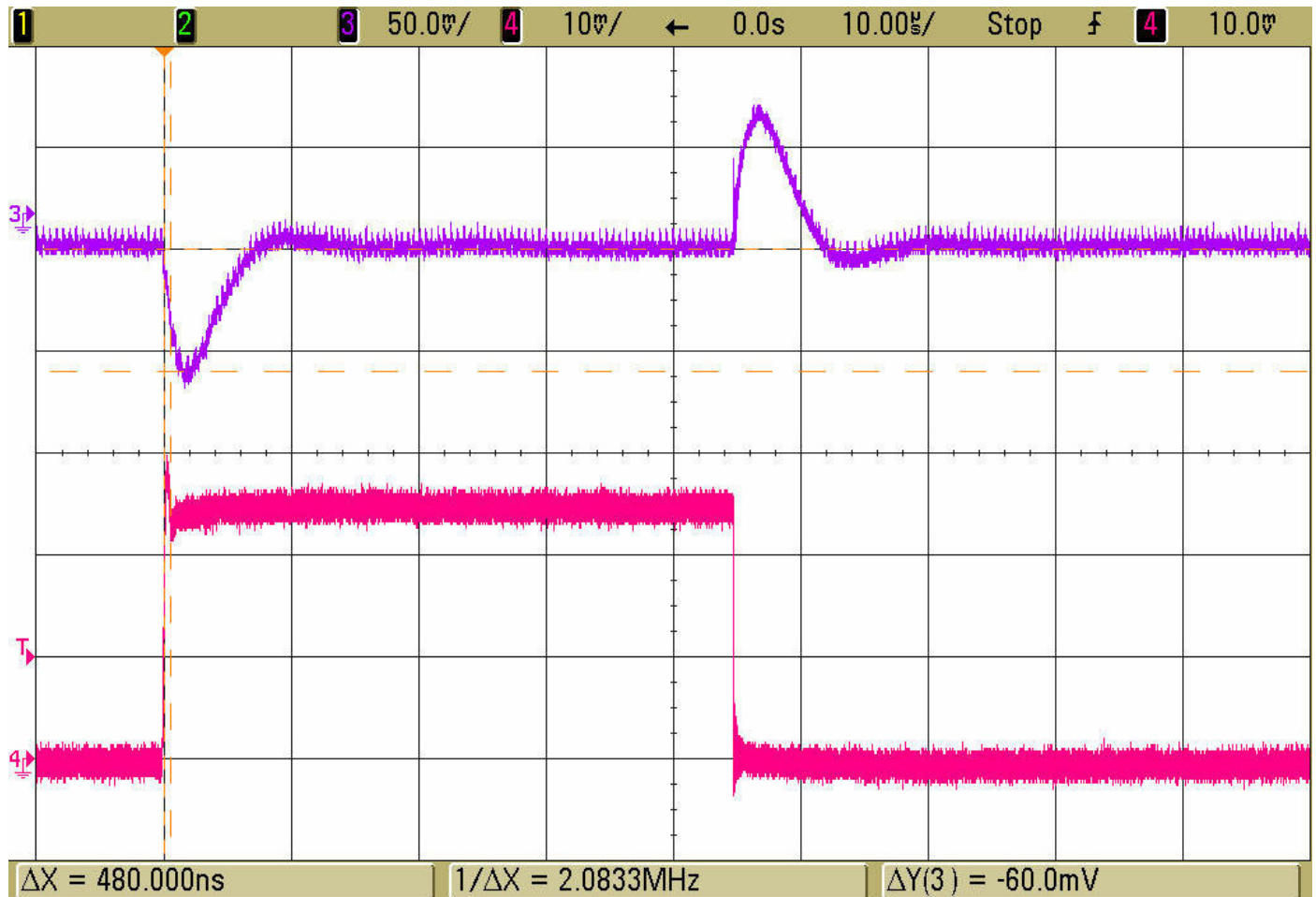
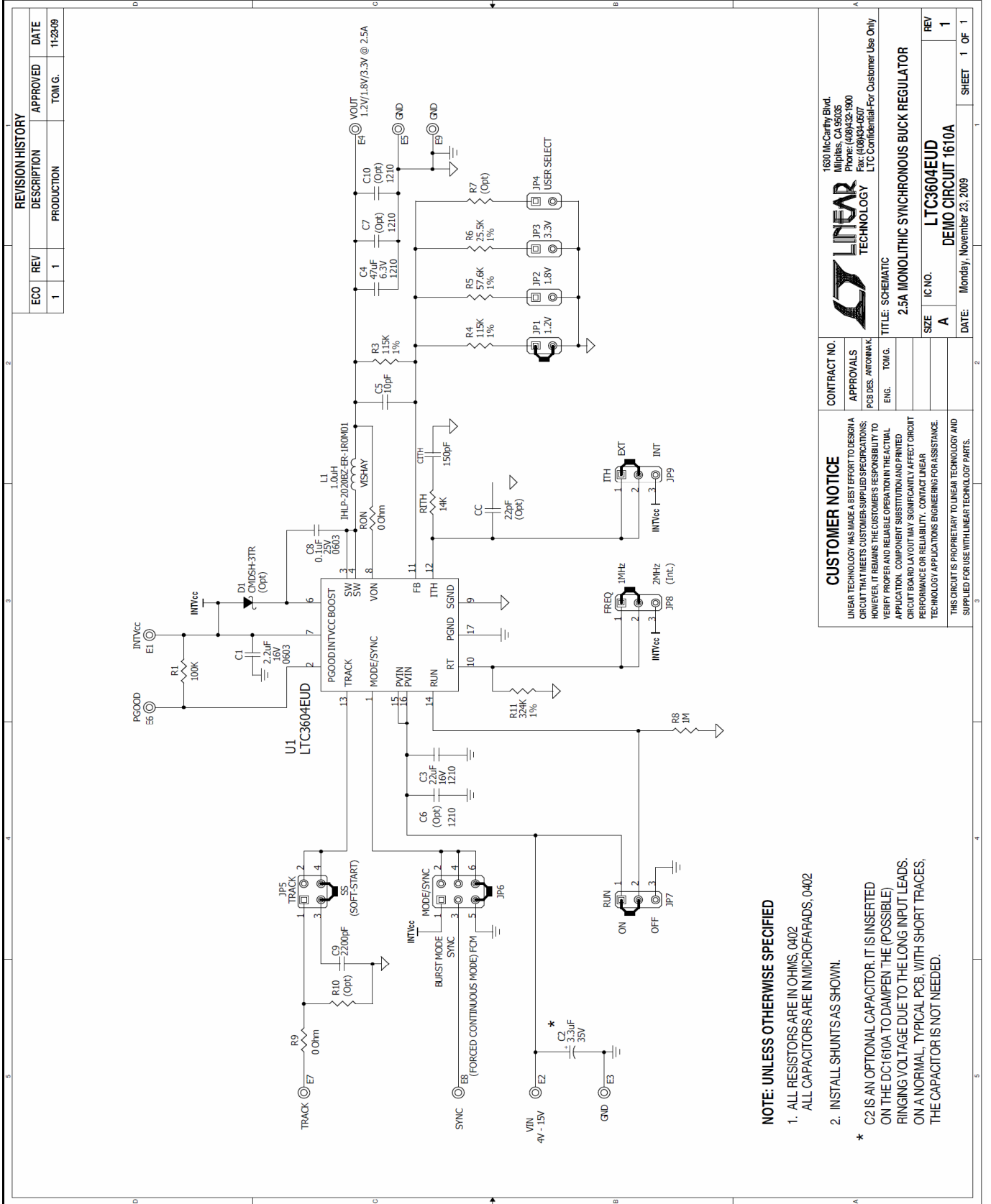

Figure 4. Load Step Response
 $V_{IN} = 12\text{V}$, $V_{OUT} = 1.8\text{V}$, 2.5A Load Step (0A \leftrightarrow 2.5A)
Forced Continuous Mode $F_{SW} = 2\text{MHz}$
Trace 3: Output Voltage (50mV/div AC)
Trace 4: Output Current (1A/div)



| REVISION HISTORY | | | | |
|------------------|-----|-------------|----------|----------|
| ECO | REV | DESCRIPTION | APPROVED | DATE |
| 1 | 1 | PRODUCTION | TOM G. | 11-23-09 |

| | | | |
|---|---------------------------|---|--------------|
| CONTRACT NO. APPROVALS PCB DES. ANTONIAK ENG. TOMG. | | 1650 McCarthy Blvd. Milpitas, CA 95035 Phone: (408)321-1900 Fax: (408)324-6507 LTC Confidential-For Customer Use Only | |
| TITLE: SCHEMATIC 2.5A MONOLITHIC SYNCHRONOUS BUCK REGULATOR | | | |
| SIZE | IC NO. | REV | |
| A | LTC3604EUD | 1 | |
| DATE: | DEMO CIRCUIT 1610A | | SHEET 1 OF 1 |
| | Monday, November 23, 2009 | | |

CUSTOMER NOTICE

LINEAR TECHNOLOGY HAS MADE A BEST EFFORT TO DESIGN A CIRCUIT THAT MEETS CUSTOMER-SUPPLIED SPECIFICATIONS; HOWEVER, IT REMAINS THE CUSTOMER'S RESPONSIBILITY TO VERIFY PROPER AND RELIABLE OPERATION IN THE ACTUAL APPLICATION. COMPONENT SUBSTITUTION AND PRINTED CIRCUIT BOARD LAYOUT MAY SIGNIFICANTLY AFFECT CIRCUIT PERFORMANCE OR RELIABILITY. CONTACT LINEAR TECHNOLOGY APPLICATIONS ENGINEERING FOR ASSISTANCE.

THIS CIRCUIT IS PROPRIETARY TO LINEAR TECHNOLOGY AND SUPPLIED FOR USE WITH LINEAR TECHNOLOGY PARTS.

NOTE: UNLESS OTHERWISE SPECIFIED

1. ALL RESISTORS ARE IN OHMS. 0402
ALL CAPACITORS ARE IN MICROFARADS, 0402
2. INSTALL SHUNTS AS SHOWN.

* C2 IS AN OPTIONAL CAPACITOR. IT IS INSERTED ON THE DC1610A TO DAMPEN THE POSSIBLE RINGING VOLTAGE DUE TO THE LONG INPUT LEADS. ON A NORMAL, TYPICAL PCB, WITH SHORT TRACES, THE CAPACITOR IS NOT NEEDED.

X-ON Electronics

Largest Supplier of Electrical and Electronic Components

Click to view similar products for [Power Management IC Development Tools](#) category:

Click to view products by [Analog Devices](#) manufacturer:

Other Similar products are found below :

[EVAL-ADM1168LQEBZ](#) [EVB-EP5348UI](#) [MIC23451-AAAYFL EV](#) [MIC5281YMME EV](#) [DA9063-EVAL](#) [ADP122-3.3-EVALZ](#) [ADP130-0.8-EVALZ](#) [ADP130-1.2-EVALZ](#) [ADP130-1.5-EVALZ](#) [ADP130-1.8-EVALZ](#) [ADP1714-3.3-EVALZ](#) [ADP1716-2.5-EVALZ](#) [ADP1740-1.5-EVALZ](#) [ADP1752-1.5-EVALZ](#) [ADP1828LC-EVALZ](#) [ADP1870-0.3-EVALZ](#) [ADP1871-0.6-EVALZ](#) [ADP1873-0.6-EVALZ](#) [ADP1874-0.3-EVALZ](#) [ADP1882-1.0-EVALZ](#) [ADP199CB-EVALZ](#) [ADP2102-1.25-EVALZ](#) [ADP2102-1.875EVALZ](#) [ADP2102-1.8-EVALZ](#) [ADP2102-2-EVALZ](#) [ADP2102-3-EVALZ](#) [ADP2102-4-EVALZ](#) [ADP2106-1.8-EVALZ](#) [ADP2147CB-110EVALZ](#) [AS3606-DB](#) [BQ24010EVM](#) [BQ24075TEVM](#) [BQ24155EVM](#) [BQ24157EVM-697](#) [BQ24160EVM-742](#) [BQ24296MEVM-655](#) [BQ25010EVM](#) [BQ3055EVM](#) [NCV891330PD50GEVB](#) [ISLUSBI2CKIT1Z](#) [LM2744EVAL](#) [LM2854EVAL](#) [LM3658SD-AEV/NOPB](#) [LM3658SDEV/NOPB](#) [LM3691TL-1.8EV/NOPB](#) [LM4510SDEV/NOPB](#) [LM5033SD-EVAL](#) [LP38512TS-1.8EV](#) [EVAL-ADM1186-1MBZ](#) [EVAL-ADM1186-2MBZ](#)