

LTC3860EUH

Wide Input Range, High Efficiency Step-Down DC/DC Converter

DESCRIPTION

Demonstration circuit DC1755A provides the user with two high current dual phase synchronous buck converters driven by the LTC3860. These buck converters provide outputs of 1.5V/50A and 1.2V/50A over an input voltage range of 6V to 14V and a switching frequency of 500kHz. The board can be easily modified for a 4-phase, single V_O , 100A supply. The power stage for each phase consists of the tri-state PWM compatible 6mm × 6mm Fairchild DrMOS module and a 0.47μH 13.2mm × 12.8mm iron powder type inductor from Würth. A high density, two sided drop-in layout is used. The entire converter, excluding the bulk output and input capacitors, fits within a 2.25" × 1.38" area on the board.

LT, LT, LTC, LTM, Linear Technology and the Linear logo are registered trademarks of Linear Technology Corporation. All other trademarks are the property of their respective owners.

The main features of the board are listed below:

- High efficiency and high current density.
- Remote sensing for each output.
- Optional resistors to tie the two outputs together.
- Connector and header to tie two or more boards together for up to 12-phase operation.
- RUN, PGOOD and TRACK/SS pins for each output.
- CLKIN and CLKOUT pins.
- Onboard bias voltage regulator.
- BNC connectors to monitor each output voltage.

Design files for this circuit board are available at <http://www.linear.com/demo>

PERFORMANCE SUMMARY ($T_A = 25^\circ\text{C}$), no airflow.

PARAMETER	CONDITIONS	VALUE
Minimum Input Voltage		6V
Maximum Input Voltage		14V
Output Voltage V_{OUTA}	$I_{OUTA} = 0\text{A to } 50\text{A}$, $V_{IN} = 6\text{V to } 14\text{V}$	1.5V ± 2%
Output Voltage V_{OUTB}	$I_{OUTB} = 0\text{A to } 50\text{A}$, $V_{IN} = 6\text{V to } 14\text{V}$	1.2V ± 2%
V_{OUTA} Maximum Output Current, I_{OUTA}	$V_{IN} = 6\text{V to } 14\text{V}$, $V_{OUTA} = 1.5\text{V}$	50A
V_{OUTB} Maximum Output Current, I_{OUTB}	$V_{IN} = 6\text{V to } 14\text{V}$, $V_{OUTB} = 1.2\text{V}$	50A
Nominal Switching Frequency		500kHz
Efficiency	$V_{OUTA} = 1.5\text{V}$, $I_{OUTA} = 50\text{A}$, $V_{IN} = 12\text{V}$	90.2% Typical
See Figures 2 and 3	$V_{OUTB} = 1.2\text{V}$, $I_{OUTB} = 50\text{A}$, $V_{IN} = 12\text{V}$	89.2% Typical

QUICK START PROCEDURE

Demonstration circuit 1755A is easy to set up to evaluate the performance of the LTC3860EUH. Please refer to Figure 1 for proper measurement equipment setup and follow the procedure below.

- 1) With power off, connect the input supply, load and meters as shown in Figure 1. Preset the load to 0A and V_{IN} supply to be 0V. Place jumpers in the following positions:

JP1	RUNA	ON
JP2	RUNB	ON
JP3	INT PWR BLK BIAS	ON

- 2) Adjust the input voltage to be between 6V to 14V. V_{OUTA} should $1.5V \pm 2\%$.
 V_{OUTB} should $1.2V \pm 2\%$.
- 3) Next, apply 50A load to each output and remeasure V_{OUT} .
- 4) Once the DC regulation is confirmed, observe the output voltage ripple, load step response, efficiency and other parameters.

Note 1. No airflow is required at room temperature with 50A on both outputs. But for ambient temperatures higher than 30°C, a cooling fan is recommended.

Note 2. Use the BNC connectors labeled V_{OUTA} or V_{OUTB} to measure the output voltage ripple.

Note 3. Do not apply the load from the $VOSA^+$ turret to the $VOSA^-$ turret or from the $VOSB^+$ turret to the $VOSB^-$ turret. These turrets are only intended to monitor the voltage across COUT3 and COUT13 respectively. Heavy load currents applied across these turrets may damage the converter.

DYNAMIC LOAD CIRCUIT (OPTIONAL)

Demonstration circuit 1755A provides a simple load step circuit consisting of a MOSFET and sense resistor for each rail. To apply a load step, follow the steps below.

- 1) Preset the amplitude of a pulse generator to 0.0V and the duty cycle to 5% or less.
- 2) Connect the scope to the VOUT BNC connectors for the rail under test with a coax cable. To monitor the load step current, connect the scope probe across the I_{STEP}^{+-} turrets for that rail.
- 3) Connect the output of the pulse generator to the PULSE GEN turret for the rail under test and connect the return to one of the GND turrets.
- 4) With the converter running, slowly increase the amplitude of the pulse generator output to provide the desired load step pulse height. The scaling for the load step signal is 10mV/A.

QUICK START PROCEDURE

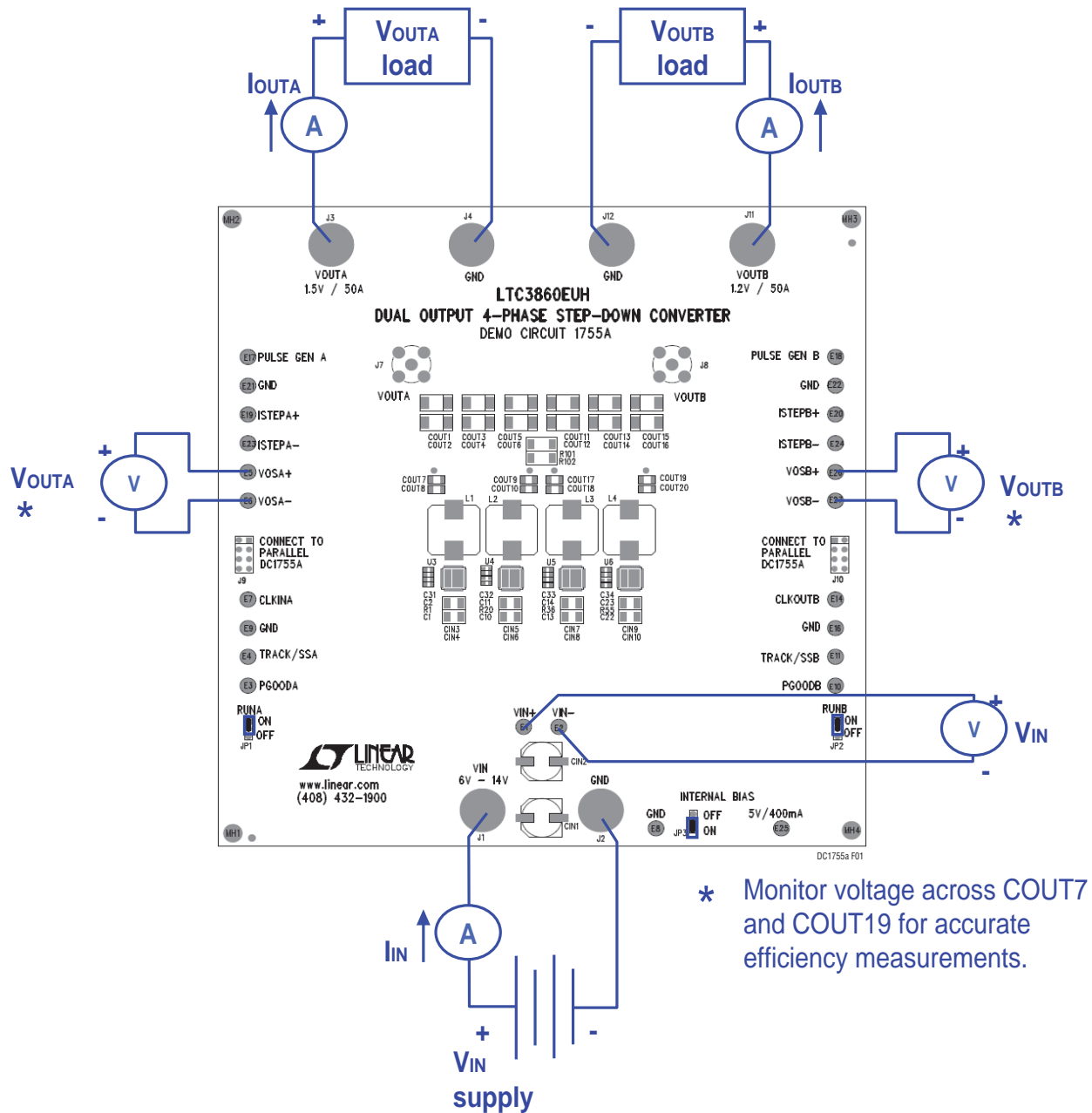
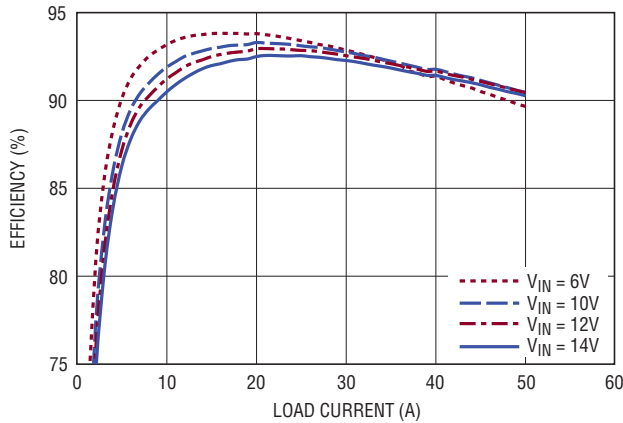

Figure 1. Proper Measurement Equipment Setup

QUICK START PROCEDURE



DC1755a F02

Figure 2. Efficiency Curves for the 1.5V Rail of the DC1755A

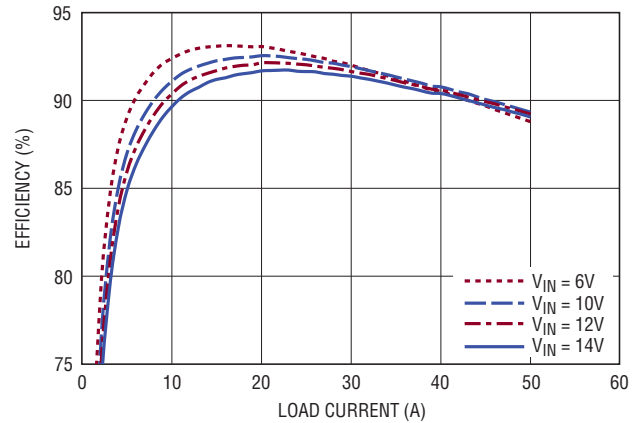

DC1755a F03

Figure 3. Efficiency Curves for the 1.2V Rail of the DC1755A

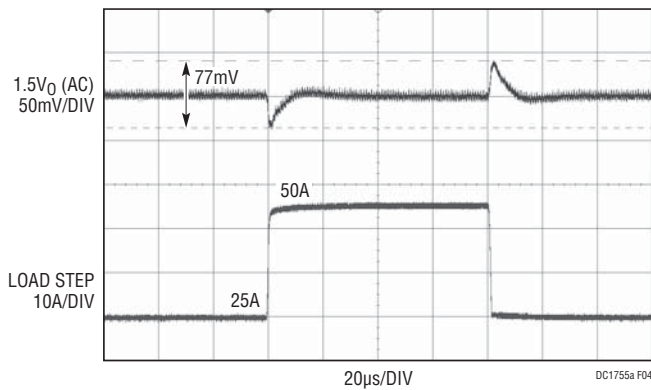

DC1755a F04

Figure 4. Load Step Response of the 1.5V Rail

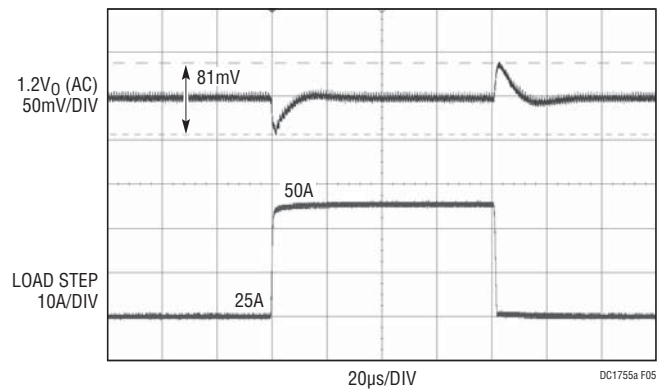

DC1755a F05

Figure 5. Load Step Response of the 1.2V Rail

SINGLE OUTPUT/4-PHASE OPERATION

A single output/4-phase converter may be preferred for higher output current applications. The optional components required to tie the phases together are found on sheet 3 of the schematic in the lower right hand corner. To tie the two outputs together, make the following modifications:

- 1) Select one rail to be the master.
 - a) If VOUTA is the master, then stuff 0Ω at R103 to disable the error amplifier for VOUTB.
 - b) If VOUTB is the master, then stuff 0Ω at R104 to disable the error amplifier for VOUTA.

- 2) Stuff 0Ω at R87, R88, R89 and R91 to tie the IAVG, COMP, TRACK/SS and RUN signals together.

- 3) Remove the redundant compensation components.

6-PHASE AND 12-PHASE OPERATION

Two or more boards may be tied together for up to 12-phase operation. To parallel two or more boards, place the boards side by side. Connect J9 of one board to J10 of the adjacent board (see sheet 3 of the schematic, lower right hand corner). This will tie the IAVG, COMP, TRACK/SS and

QUICK START PROCEDURE

RUN signals of the adjacent boards together. Next, locate the exposed copper shapes on the four corners of the board on the top and bottom layers. Use these shapes to tie the VOUT, VIN and GND planes of the adjacent boards. Next, select which phases will be the master or the slave.

Figure 6 shows the typical setup for a 6-phase + 2-phase converter. Figure 7 shows the typical setup for a 12-phase converter. For additional help and support, contact your local LTC sales office.

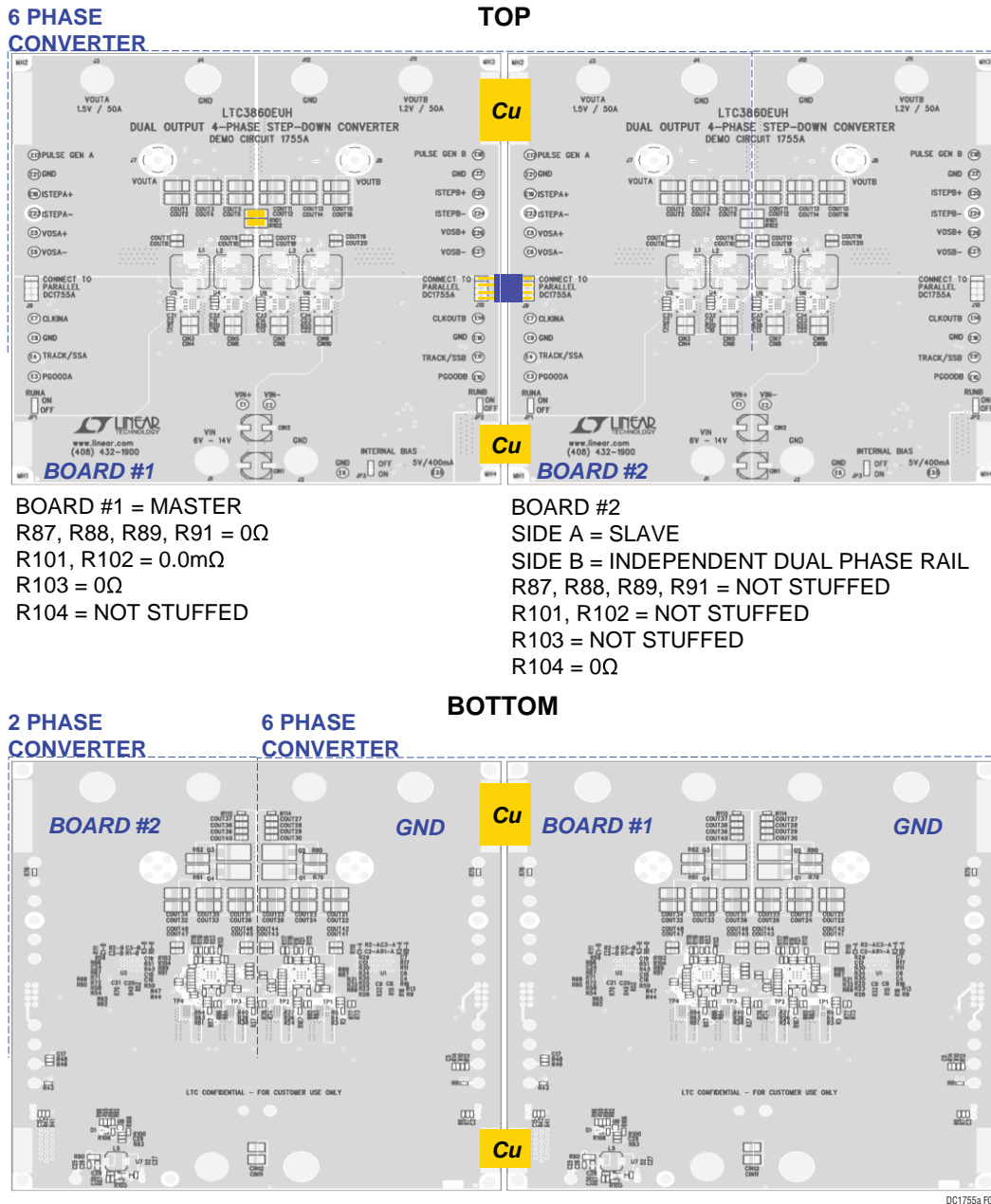

Figure 6. Typical Setup for a 6-Phase + 2-Phase Converter

PARTS LIST

ITEM	QTY	REFERENCE	PART DESCRIPTION	MANUFACTURER/PART NUMBER
Required Circuit Components				
1	1	CIN1	CAP, 180µF 20% 16V OSCON	SANYO 16SVP180MX
2	4	CIN3, CIN5, CIN7, CIN9	CAP, 1210 22µF 20% 16V X5R	TDK C3225X5R1C226M
3	12	COU1 to COU3, COU4 to COU6, COU11 to COU13, COU14 to COU16	CAP, 7343 330µF 20% 2.5V POSCAP	SANYO 2R5TPE330M9L
4	8	COU7 to COU10, COU17 to COU20	CAP, 1206 100µF 20% 6.3V X5R	MURATA GRM31CR60J107ME39L
5	2	C1 to A, C1 to B	CAP, 0603 470pF 10% 25V NPO	AVX 06033A471KAT2A
6	8	C1, C8, C9, C10, C13, C20, C21, C22	CAP, 0603 0.22µF 10% 25V X7R	TDK C1608X7R1E224K
7	8	C2, C11, C14, C23, C31, C32, C33, C34	CAP, 0603 2.2µF 10% 16V X7R	MURATA GRM188R61C225KE15
8	2	C4, C16	CAP, 0603 100pF 5% 25V NPO	AVX 06033A101JAT2A
9	2	C2 to A, C2 to B	CAP, 0603 68pF 5% 25V NPO	AVX 06033A680JAT2A
10	2	C3 to A, C3 to B	CAP, 0603 2200pF 25V X7R	MURATA GRM188R71E222MA01
11	3	C7, C19, C28	CAP, 0603 1µF 20% 25V X5R	AVX 06033D105MAT2A
12	4	L1, L2, L3, L4	IND, 0.47µH 20%	WÜRTH 744355147
13	1	RB to A	RES, 0603 13.3k 1% 1/10W	VISHAY CRCW060313K3FKEA
14	1	RB to B	RES, 0603 20k 1% 1/10W	NIC NRC06F2002TRF
15	19	R1, R11, R12, R16, R20, R25, R36, R45, R46, R50, R54, R55, R59, R62, R69, R112, R113, R116, R118	RES, 0603 0Ω JUMPER	VISHAY CRCW06030000Z0EA
16	2	R1 to A, R1 to B	RES, 0603 20k 1% 1/10W	NIC NRC06F2002TRF
17	6	R2, R17, R37, R51, R57, R107	RES, 0603 1Ω 5% 1/10W	VISHAY CRCW06031R00JNEA
18	2	R2 to A, R2 to B	RES, 0603 6.8k 1% 1/10W	VISHAY CRCW06036K80FKEA
19	2	R3 to A, R3 to B	RES, 0603 523Ω 1% 1/10W	VISHAY CRCW0603523RFKEA
20	9	R3, R4, R24, R26, R31, R38, R39, R61, R63	RES, 0603 10k 1% 1/10W	VISHAY CRCW060310K0FKEA
21	2	R8, R43	RES, 0603 100k 5% 1/10W	YAGEO RC0603JR-07100KL
22	4	R15, R33, R49, R70	RES, 0603 2.87k 1% 1/10W	VISHAY CRCW06032K87FKEA
23	2	R18, R52	RES, 0603 59.0k 1% 1/10W	VISHAY CRCW060359K0FKEA
24	4	R19, R21, R53, R56	RES, 0603 10Ω 1% 1/10W	NIC NRC06F10R0TRF
25	2	R30, R67	RES, 0603 40.2k 1% 1/10W	VISHAY CRCW060340K2FKEA
26	2	U1, U2	IC, DUAL OUTPUT BUCK CONVERTER	LINEAR TECHNOLOGY LTC3860EUH
27	4	U3, U4, U5, U6	INTEGRATED MOSFET, DC/DC CONVERTER	FAIRCHILD FDMF6707B
Bias Supply and UVLO Circuit				
1	1	C29	CAP, 0603 2.2µF 10% 16V X7R	MURATA GRM188R61C225KE15
2	1	C25	CAP, 0603 1µF 20% 25V X5R	AVX 06033D105MAT2A
3	1	C26	CAP, 0805 10µF 10% 25V NPO	AVX 08053D106MAT2A
4	1	C27	CAP, 0603 0.1µF 10% 16V X7R	AVX 0603YC104KAT2A
5	1	C30	CAP, 0603 10pF 5% 50V NPO	MURATA GQM1885C1H100JB01
6	1	D1	DIODE, BAV170 SOT23	DIODES INC., BAV170
7	1	D2	DIODE SHOTTKY SOD326	NXP PMEG2005AEA
8	1	L5	INDUCTOR 27µH 20%	WÜRTH 7447789127
9	1	R105	RES, 0603 20k 1% 1/10W	NIC NRC06F2002TRF
10	1	R106	RES, 0603 10k 1% 1/10W	VISHAY CRCW060310K0FKEA

DEMO MANUAL DC1755A

PARTS LIST

ITEM	QTY	REFERENCE	PART DESCRIPTION	MANUFACTURER/PART NUMBER
11	1	R90	RES, 1206 0Ω JUMPER	VISHAY CRCW12060000Z0EA
12	1	R93	RES, 0603 100Ω 5% 1/10W	VISHAY CRCW0603100RFKEA
13	1	R97	RES, 0603 105k 1% 1/10W	VISHAY CRCW0603105KFKEA
14	1	R100	RES, 0603 127k 1% 1/10W	VISHAY CRCW0603127KFKEA
15	1	U7	IC, STEP DOWN REGULATOR, DFN	LINEAR TECHNOLOGY LT3502EDC
16	1	U8	IC, VOLTAGE MONITOR, DC-3	LINEAR TECHNOLOGY LT6703IDC-3

Additional Circuit Components

1	0	CIN2	CAP, SANYO SVP-F8	OPTIONAL
2	0	CIN4, CIN6, CIN8, CIN10 to CIN12	CAP, 1210	OPTIONAL
3	0	COU21 to COU26, COU31 to COU36	CAP, 7343H	OPTIONAL
4	0	COU27 to COU30, COU37 to COU48	CAP, 1206	OPTIONAL
5	0	R5, R6, R7, R9, R10, R13, R14, R23, R27, R28, R29, R32, R34, R35, R40, R41, R42, R44, R47, R48, R58, R60, R64, R65, R66, R68, R71, R72, R87, R88, R89, R91, R92, R94, R95, R96, R103, R104, R108, R110, R111, R114, R115, R117, R119	RES, 0603	OPTIONAL
6	0	C3, C5, C6, C12, C15, C17, C18, C24	CAP, 0603	OPTIONAL
7	0	Q2, Q3	MOSFET, TO-252	OPTIONAL
8	0	R73, R74, R77, R78, R83, R84, R85, R86	RES, 0603	OPTIONAL
9	0	R80, R82, R101, R102	RES, 2010	OPTIONAL
10	2	Q1, Q4	MOSFET, TO-252	VISHAY SUD50N03-09P
11	2	R75, R76	RES, 0603 10k 1% 1/10W	VISHAY CRCW060310K0FKEA
12	2	R79, R81	RES, 2010 0.010Ω 2% 1W	IRC LRC-LRF2010LF-01-R010-F

Hardware/Components (For Demo Board Only)

1	4		STANDOFF, SNAP ON	KEYSTONE 8831
2	12		NUT, BRASS #10-32	ANY
3	6		RING, LUG #10	KEYSTONE 8205
4	6		WASHER, TIN, PLATED BRASS	ANY
5	24	E1 to E11, E14, E16, E17 to E27	TURRET	MILL MAX 2501-2-00-80-00-00-07-0
6	3	JP1 to JP3	HEADER, 3 PIN	SAMTEC TMM-103-02-L-S
7	3	XJP1 to XJP3	SHUNT, 2mm CTRS	SAMTEC 2SN-BK-G
8	6	J1 to J4, J11, J12	STUD, TEST PIN	PEM KFH-032-10
9	2	J7, J8	CON, BNC, 5 PINS	CONNEX 112404
10	1	J9	HEADER, DOUBLE ROW, RIGHT ANGLE	MILL-MAX 802-40-008-20-001000
11	1	J10	SOCKET, DOUBLE ROW	MILL-MAX 803-43-008-20-001000

SCHEMATIC DIAGRAM

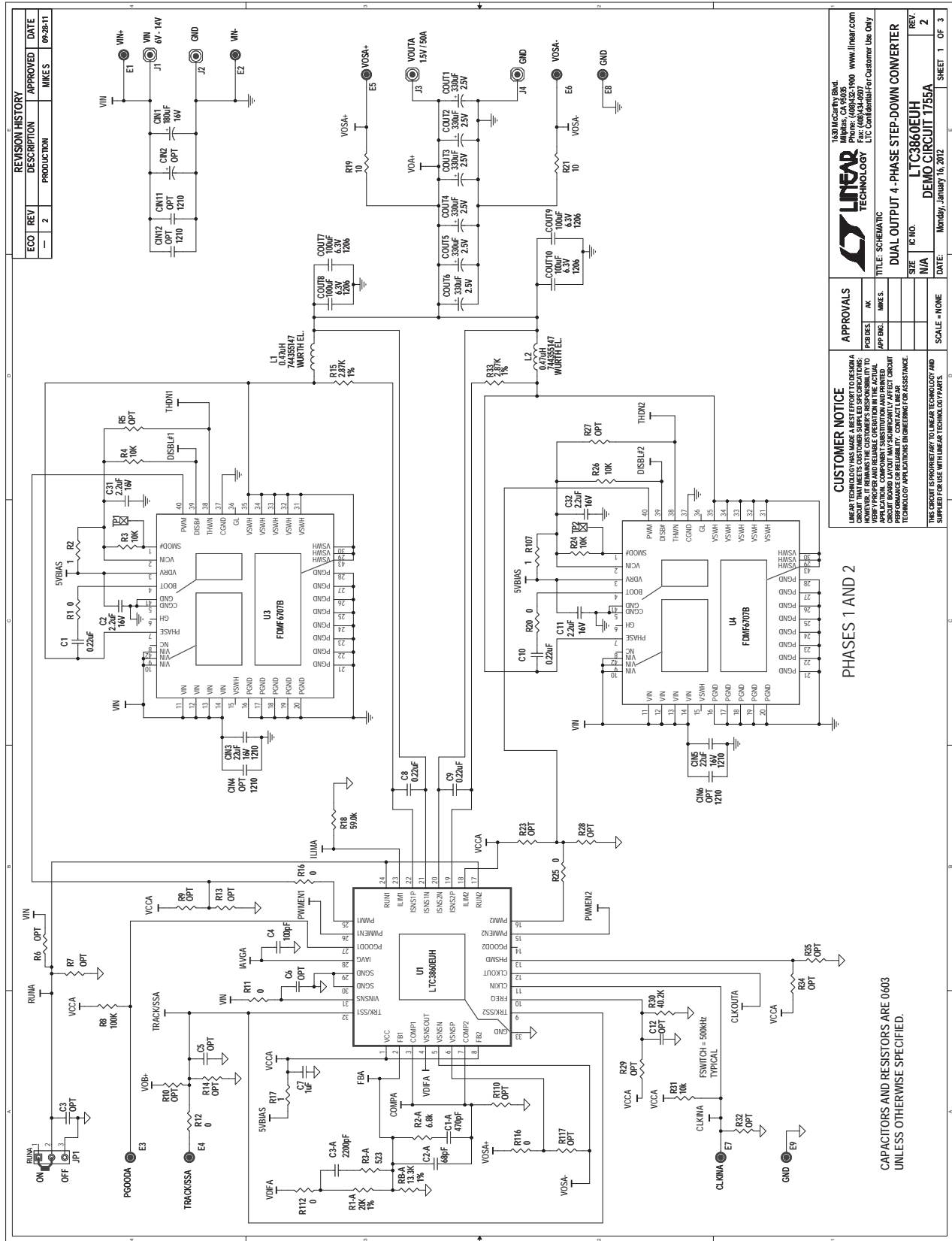

1630 McCarthy Blvd.
 Milpitas, CA 95035
 Tel: (415) 964-8000
 Fax: (415) 964-8007
 www.linear.com

LINEAR TECHNOLOGY

TITLE: SCHEMATIC
 DUAL OUTPUT 4-PHASE STEP-DOWN CONVERTER
 DEMO CIRCUIT 1755A

REV: 2

DATE: Monday, January 16, 2012

SHEET 1 OF 3

DEMO MANUAL DC1755A

SCHEMATIC DIAGRAM

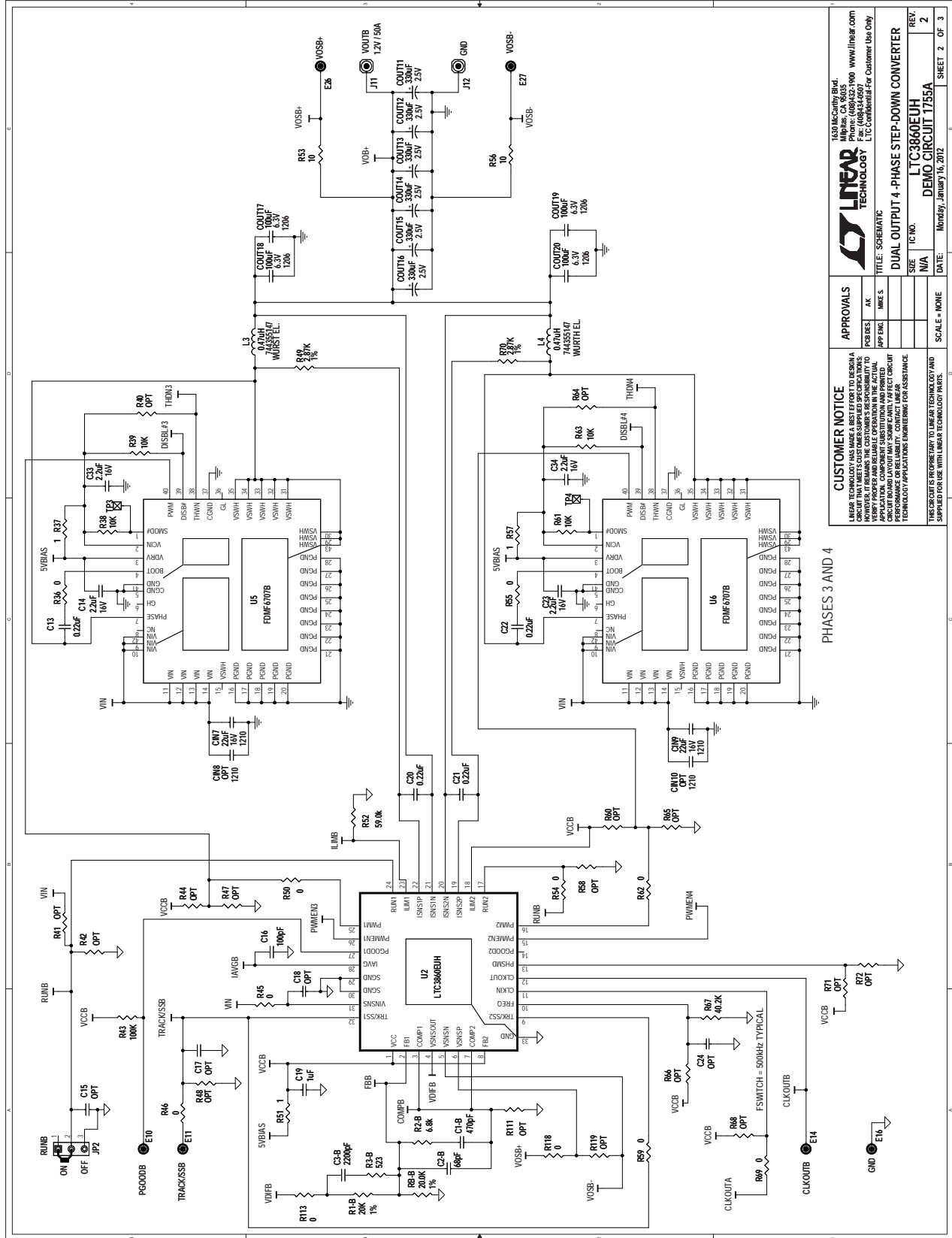

CUSTOMER NOTICE
 LINEAR TECHNOLOGY MAKES NO WARRANTY, REPRESENTATION OR GUARANTEE, EXPRESS OR IMPLIED, REGARDING THE USE OF THIS SCHEMATIC IN ANY APPLICATION. COMPONENT SUBSTITUTION AND PRINTED CIRCUIT BOARD MANUFACTURING VARIATIONS MAY AFFECT PERFORMANCE OR RELIABILITY. CONTACT LINEAR TECHNOLOGY APPLICATIONS ENGINEERING FOR ASSISTANCE.
 THIS CIRCUIT IS PROPRIETARY TO LINEAR TECHNOLOGY AND SUPPLIED FOR USE WITH LINEAR TECHNOLOGY PARTS.

APPROVALS	
DESIGNER	AK
APP. ENG.	MRE S
DATE	SCALE = NONE

1630 McCarty Blvd.
 Milpitas, CA 95035
 Tel: (415) 964-8000 www.linear.com
 Fax: (415) 964-8607
 LTC Confidential For Customer Use Only

TITLE: SCHEMATIC
 DUAL OUTPUT 4-PHASE STEP-DOWN CONVERTER
 SIZE: N/A
 IC NO.: LTC3860EUH
 DEMO CIRCUIT 1755A
 DATE: Monday, January 16, 2012
 SHEET 2 OF 3

SCHEMATIC DIAGRAM

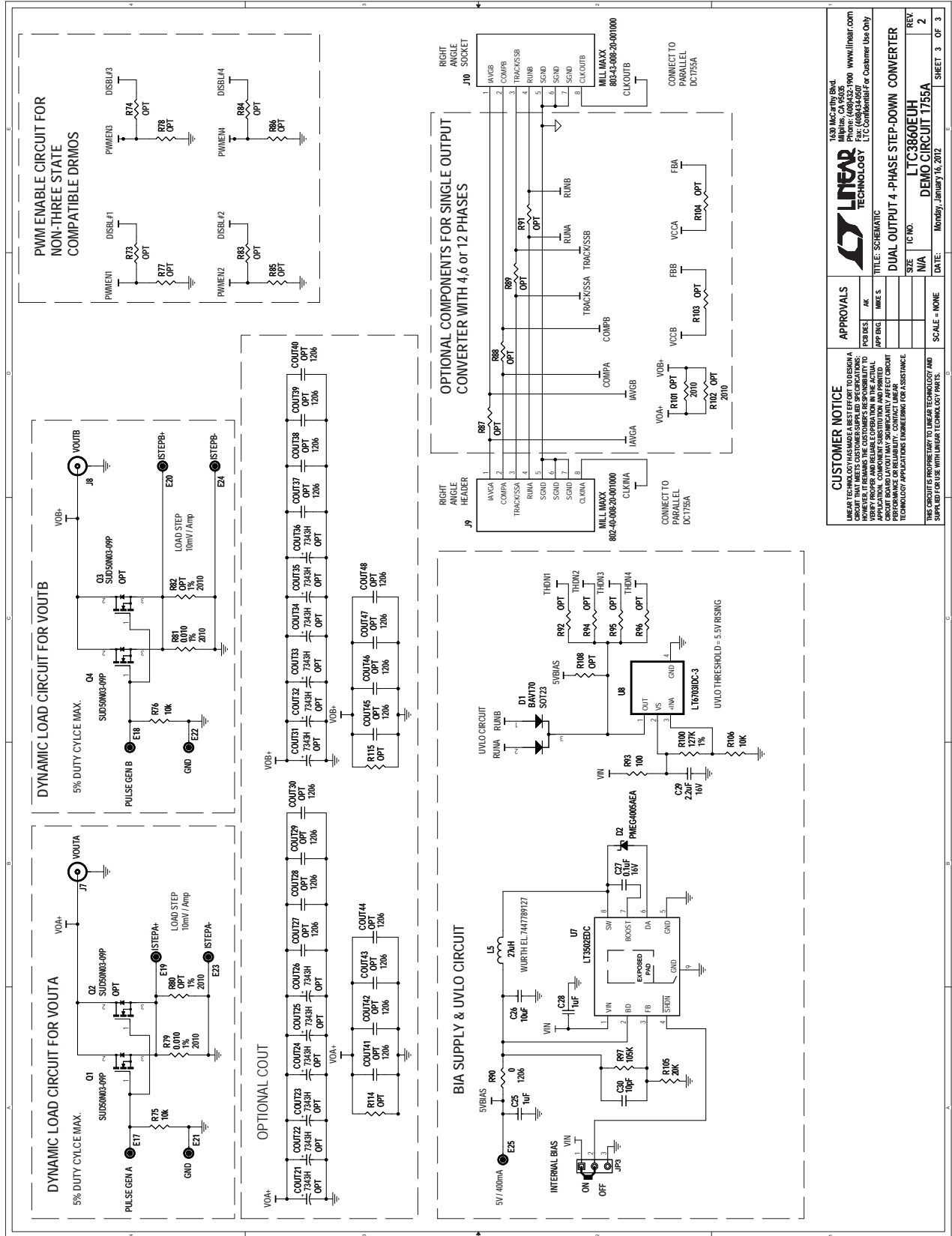

Information furnished by Linear Technology Corporation is believed to be accurate and reliable. However, no responsibility is assumed for its use. Linear Technology Corporation makes no representation that the interconnection of its circuits as described herein will not infringe on existing patent rights.

DEMO MANUAL DC1755A

DEMONSTRATION BOARD IMPORTANT NOTICE

Linear Technology Corporation (LTC) provides the enclosed product(s) under the following **AS IS** conditions:

This demonstration board (DEMO BOARD) kit being sold or provided by Linear Technology is intended for use for **ENGINEERING DEVELOPMENT OR EVALUATION PURPOSES ONLY** and is not provided by LTC for commercial use. As such, the DEMO BOARD herein may not be complete in terms of required design-, marketing-, and/or manufacturing-related protective considerations, including but not limited to product safety measures typically found in finished commercial goods. As a prototype, this product does not fall within the scope of the European Union directive on electromagnetic compatibility and therefore may or may not meet the technical requirements of the directive, or other regulations.

If this evaluation kit does not meet the specifications recited in the DEMO BOARD manual the kit may be returned within 30 days from the date of delivery for a full refund. **THE FOREGOING WARRANTY IS THE EXCLUSIVE WARRANTY MADE BY THE SELLER TO BUYER AND IS IN LIEU OF ALL OTHER WARRANTIES, EXPRESSED, IMPLIED, OR STATUTORY, INCLUDING ANY WARRANTY OF MERCHANTABILITY OR FITNESS FOR ANY PARTICULAR PURPOSE. EXCEPT TO THE EXTENT OF THIS INDEMNITY, NEITHER PARTY SHALL BE LIABLE TO THE OTHER FOR ANY INDIRECT, SPECIAL, INCIDENTAL, OR CONSEQUENTIAL DAMAGES.**

The user assumes all responsibility and liability for proper and safe handling of the goods. Further, the user releases LTC from all claims arising from the handling or use of the goods. Due to the open construction of the product, it is the user's responsibility to take any and all appropriate precautions with regard to electrostatic discharge. Also be aware that the products herein may not be regulatory compliant or agency certified (FCC, UL, CE, etc.).

No License is granted under any patent right or other intellectual property whatsoever. **LTC assumes no liability for applications assistance, customer product design, software performance, or infringement of patents or any other intellectual property rights of any kind.**

LTC currently services a variety of customers for products around the world, and therefore this transaction **is not exclusive**.

Please read the DEMO BOARD manual prior to handling the product. Persons handling this product must have electronics training and observe good laboratory practice standards. **Common sense is encouraged.**

This notice contains important safety information about temperatures and voltages. For further safety concerns, please contact a LTC application engineer.

Mailing Address:

Linear Technology
1630 McCarthy Blvd.
Milpitas, CA 95035

Copyright © 2004, Linear Technology Corporation

X-ON Electronics

Largest Supplier of Electrical and Electronic Components

Click to view similar products for [Power Management IC Development Tools](#) category:

Click to view products by [Analog Devices](#) manufacturer:

Other Similar products are found below :

[EVAL-ADM1168LQEBZ](#) [EVB-EP5348UI](#) [MIC23451-AAAYFL EV](#) [MIC5281YMME EV](#) [DA9063-EVAL](#) [ADP122-3.3-EVALZ](#) [ADP130-0.8-EVALZ](#) [ADP130-1.2-EVALZ](#) [ADP130-1.5-EVALZ](#) [ADP130-1.8-EVALZ](#) [ADP1714-3.3-EVALZ](#) [ADP1716-2.5-EVALZ](#) [ADP1740-1.5-EVALZ](#) [ADP1752-1.5-EVALZ](#) [ADP1828LC-EVALZ](#) [ADP1870-0.3-EVALZ](#) [ADP1871-0.6-EVALZ](#) [ADP1873-0.6-EVALZ](#) [ADP1874-0.3-EVALZ](#) [ADP1882-1.0-EVALZ](#) [ADP199CB-EVALZ](#) [ADP2102-1.25-EVALZ](#) [ADP2102-1.875EVALZ](#) [ADP2102-1.8-EVALZ](#) [ADP2102-2-EVALZ](#) [ADP2102-3-EVALZ](#) [ADP2102-4-EVALZ](#) [ADP2106-1.8-EVALZ](#) [ADP2147CB-110EVALZ](#) [AS3606-DB](#) [BQ24010EVM](#) [BQ24075TEVM](#) [BQ24155EVM](#) [BQ24157EVM-697](#) [BQ24160EVM-742](#) [BQ24296MEVM-655](#) [BQ25010EVM](#) [BQ3055EVM](#) [NCV891330PD50GEVB](#) [ISLUSBI2CKIT1Z](#) [LM2744EVAL](#) [LM2854EVAL](#) [LM3658SD-AEV/NOPB](#) [LM3658SDEV/NOPB](#) [LM3691TL-1.8EV/NOPB](#) [LM4510SDEV/NOPB](#) [LM5033SD-EVAL](#) [LP38512TS-1.8EV](#) [EVAL-ADM1186-1MBZ](#) [EVAL-ADM1186-2MBZ](#)