

LTC2997 Remote/Internal Temperature Sensor

DESCRIPTION

Demonstration circuit 1767 features the LTC[®]2997, a high accuracy, analog output, temperature sensor.

DC1767 is designed to allow easy evaluation of the LTC2997.

Design files for this circuit board are available at <http://www.linear.com/demo>

LT, LT, LTC, LTM, Linear Technology and the Linear logo are registered trademarks of Linear Technology Corporation. All other trademarks are the property of their respective owners.

QUICK START PROCEDURE

Jumper Settings

D+/D-: These jumpers select which temperature input connects to the LTC2997. INT uses the internal temperature sensor, EXT uses an off-board sensor connected to the D+/D- analog inputs, and Q1 uses the transistor stuffed in Q1 (the MMBT3904 by default).

Analog Connections

Analog signal connections are made via the row of turret posts along the edges of the board.

GND: (2 turrets) These turrets connect directly to the internal ground planes.

VCC: Connect a 2.25V to 5.5V power supply to this turret.

D+/D-: Should be set to EXT. This is where the external diode should be connected.

VREF: Output Only. 1.8V output that can drive up to $\pm 200\mu\text{A}$ of load.

VPTAT: The voltage on this turret is proportional to the sensor's absolute temperature, with a slope of 4mV/K. VPTAT can drive up to a $\pm 200\mu\text{A}$ load and up to 1000pF capacitive load.

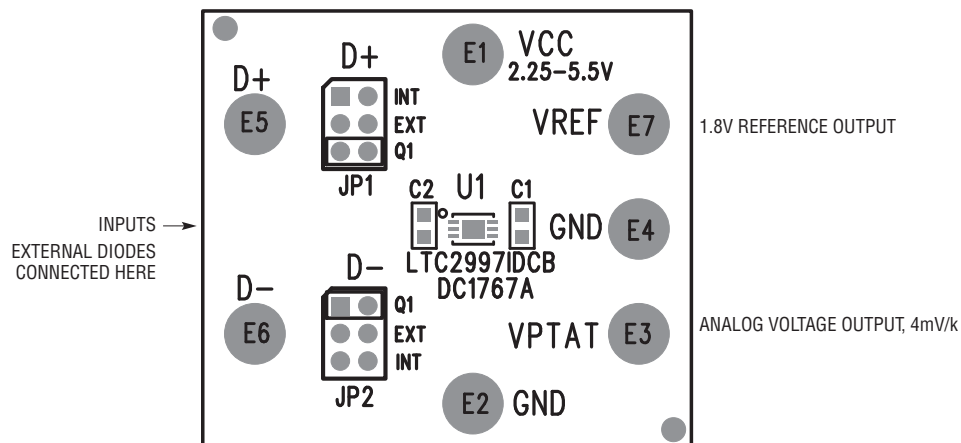

Figure 1. Proper Measurement Equipment Setup

DEMO MANUAL DC1767

PARTS LIST

ITEM	QTY	REFERENCE	PART DESCRIPTION	MANUFACTURER/PART NUMBER
1	1	C1	CAP., X7R, 0.1 μ F, 10V 20% 0603	AVX, 0603ZC104MAT
2	1	C2	CAP., X7R, 470pF, 10V 10% 0603	AVX, 0603ZC471KAT2A
3	7	E1, E2, E3, E4, E5, E6, E7	TESTPOINT, TURRET, 0.094, PBF	MILL- MAX, 2501-2-00-80-00-00-07-0
4	2	JP1, JP2	HEADER, 3 PIN 0.079 DUAL ROW	SAMTEC, TMM-103-02-L-D
5	1	Q1	XISTOR MMBT3904 SOT-23	ON SEMI., MMBT3904LT1G
6	1	R1	RES., CHIP, 1k, 1/10W, 5% 0603	YAGEO, RC0603JR-071KL
7	1	U1	IC, LTC2997IDCB	LINEAR TECH., LTC2997IDCB#TRPBF
8	2	XJ1, XJ2	SHUNT, 0.079" CENTER	DEMO CIRCUIT 1767A
9	1		FAB, PRINTED CIRCUIT BD	
10	2		STENCIL (TOP & BOTTOM)	STENCIL DC1767A

SCHEMATIC DIAGRAM

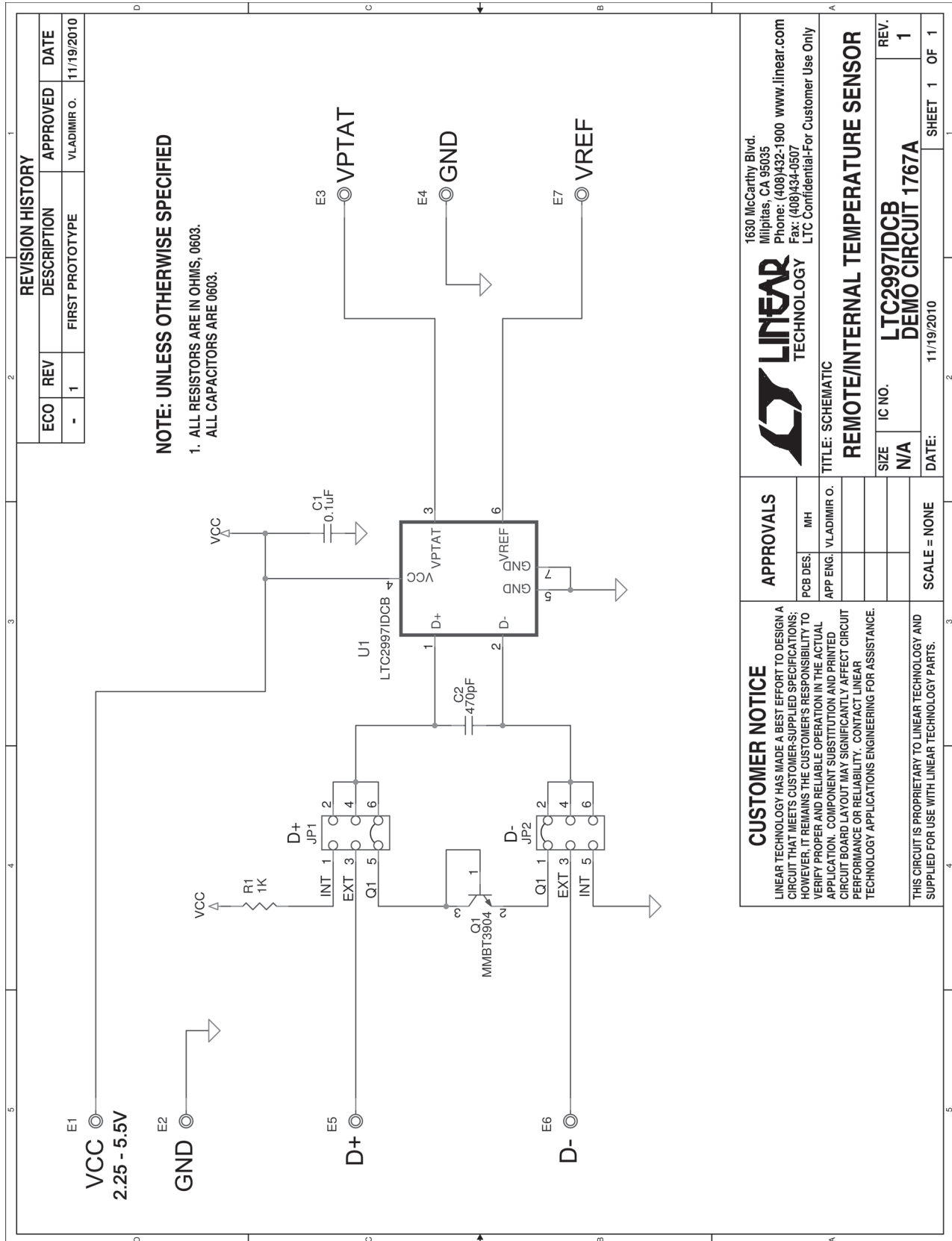

dc1767f

DEMO MANUAL DC1767

DEMONSTRATION BOARD IMPORTANT NOTICE

Linear Technology Corporation (LTC) provides the enclosed product(s) under the following **AS IS** conditions:

This demonstration board (DEMO BOARD) kit being sold or provided by Linear Technology is intended for use for **ENGINEERING DEVELOPMENT OR EVALUATION PURPOSES ONLY** and is not provided by LTC for commercial use. As such, the DEMO BOARD herein may not be complete in terms of required design-, marketing-, and/or manufacturing-related protective considerations, including but not limited to product safety measures typically found in finished commercial goods. As a prototype, this product does not fall within the scope of the European Union directive on electromagnetic compatibility and therefore may or may not meet the technical requirements of the directive, or other regulations.

If this evaluation kit does not meet the specifications recited in the DEMO BOARD manual the kit may be returned within 30 days from the date of delivery for a full refund. **THE FOREGOING WARRANTY IS THE EXCLUSIVE WARRANTY MADE BY THE SELLER TO BUYER AND IS IN LIEU OF ALL OTHER WARRANTIES, EXPRESSED, IMPLIED, OR STATUTORY, INCLUDING ANY WARRANTY OF MERCHANTABILITY OR FITNESS FOR ANY PARTICULAR PURPOSE. EXCEPT TO THE EXTENT OF THIS INDEMNITY, NEITHER PARTY SHALL BE LIABLE TO THE OTHER FOR ANY INDIRECT, SPECIAL, INCIDENTAL, OR CONSEQUENTIAL DAMAGES.**

The user assumes all responsibility and liability for proper and safe handling of the goods. Further, the user releases LTC from all claims arising from the handling or use of the goods. Due to the open construction of the product, it is the user's responsibility to take any and all appropriate precautions with regard to electrostatic discharge. Also be aware that the products herein may not be regulatory compliant or agency certified (FCC, UL, CE, etc.).

No License is granted under any patent right or other intellectual property whatsoever. **LTC assumes no liability for applications assistance, customer product design, software performance, or infringement of patents or any other intellectual property rights of any kind.**

LTC currently services a variety of customers for products around the world, and therefore this transaction **is not exclusive**.

Please read the DEMO BOARD manual prior to handling the product. Persons handling this product must have electronics training and observe good laboratory practice standards. **Common sense is encouraged.**

This notice contains important safety information about temperatures and voltages. For further safety concerns, please contact a LTC application engineer.

Mailing Address:

Linear Technology
1630 McCarthy Blvd.
Milpitas, CA 95035

Copyright © 2004, Linear Technology Corporation

dc1767f

X-ON Electronics

Largest Supplier of Electrical and Electronic Components

Click to view similar products for [Temperature Sensor Development Tools](#) category:

Click to view products by [Analog Devices](#) manufacturer:

Other Similar products are found below :

[EVAL-ADT7516EBZ](#) [EVAL-ADT75EBZ](#) [T20321SS2B](#) [T2016P2CRRXC4S2](#) [MAX1455EVKIT-NS](#) [DC2507A](#) [DS18B20EVKIT#](#)
[MAX6654EVKIT](#) [EV-TEMPSENSE-ARDZ](#) [MAX1617AEVKIT](#) [BB-WSK-REF-2](#) [MCP9800DM-TS1](#) [TMPSNSRD-RTD2](#) [MIKROE-2273](#)
[MIKROE-2501](#) [MIKROE-2539](#) [MIKROE-2554](#) [DPP201Z000](#) [DPP901Z000](#) [1899](#) [EV-BUNCH-WSN-2Z](#) [DPP904R000](#) [KIT0021](#) [SEN0206](#)
[SEN0227](#) [MIKROE-2769](#) [3251](#) [SEN-13314](#) [3263](#) [SEN0137](#) [LM20XEVM](#) [3328](#) [TMP708EVM](#) [BOOSTXL-TMP107](#) [DC1785B](#) [MHUM-01](#)
[3538](#) [DPP201G000](#) [DFR0066](#) [WPP100B009](#) [SDT310LTC100A3850](#) [SI7005EVB-UDP-M3L1](#) [2857](#) [1782](#) [2652](#) [269](#) [3245](#) [3622](#) [3648](#)
[3721](#)