

LTC3260EMSE

High Voltage, Low Noise, Dual Supply Inverting Charge Pump

DESCRIPTION

Demonstration circuit 1793A is a high voltage inverting charge pump with low noise dual-polarity LDO regulators featuring the LTC[®]3260EMSE. The LTC3260 operates with an input voltage from 4.5V to 32V. The demo board provides selectable LDO_± output set magnitudes of 3.3V, 5V, 12V and 24V for each polarity. Additional LDO_± set point jumper selections and optional topside ADJ_± resistors allow the user to set other desired LDO_± output voltages. The demo board also provides the means to select between Burst Mode[®] operation or constant-frequency

mode operation, plus select an operating frequency of 500kHz, 200kHz, and 50kHz.

The LTC3260 data sheet gives a complete description of the device, operation and application information. The data sheet must be read in conjunction with this quick start guide for demo circuit 1793A.

Design files for this circuit board are available at <http://www.linear.com/demo>

LT, LT, LTC, LTM, Linear Technology, the Linear logo and Burst Mode are registered trademarks of Linear Technology Corporation. All other trademarks are the property of their respective owners.

PERFORMANCE SUMMARY Specifications are at T_A = 25°C

SYMBOL	PARAMETER	CONDITIONS	MIN	TYP	MAX	UNITS
V _{IN}	Input Voltage		4.5		32	V
VLDO+	LDO+ Output Voltage	V _{IN} ≥ LDO+ Set Point + 0.8V	1.2		32	V
VLDO-	LDO- Output Voltage	V _{OUT} ≤ LDO- Set Point - 0.5V	-32		-1.2	V
V _{OUT}	Output Voltage	MODE = 0V MODE ≥ 2V		-V _{IN} -0.94 • V _{IN}		V V

QUICK START PROCEDURE

Refer to Figure 1 for the proper measurement equipment setup and jumper settings, and follow the procedure below.

NOTE: When measuring the input or output voltage ripple, care must be taken to avoid a long ground lead on the oscilloscope probe. Measure the input or output voltage ripple by touching the probe tip directly across the V_{IN} or V_{OUT} and GND terminals. See Figure 2 for proper scope probe technique.

- Make sure the jumper settings are as follows:
 - JP1:** EN+ is in the ON position.
 - JP2:** EN- is in the ON position.
 - JP3:** MODE is in the BURST position.
 - JP4:** FREQ is in the 500kHz position.
 - JP5:** LDO+ is set to the 5V setting.
 - JP6:** LDO- is set to the -5V setting.
- Set PS1 to 12V.

QUICK START PROCEDURE

3. Slowly increase the load on LDO- to -50mA and observe how the output ripple on V_{OUT} changes and how the burst frequency increases. When the load is large enough, the charge pump will run constant frequency to keep V_{OUT} in regulation.
 4. Slowly increase the load on LDO+ to 50mA and observe the output ripple and the output voltage on LDO+.
 5. Set the LDO+ load and the LDO- load to 0mA and turn off PS1.
- NOTE: To avoid applying an overvoltage to the ADJ_{\pm} pins, power must be turned off before changing the LDO+ or LDO- jumpers.
6. Set the JP5 LDO+ jumper to the 3.3V position and JP6 LDO- to the -3.3V position.
 7. Repeat steps 2 through 5.
 8. Set the JP5 LDO+ jumper to the 12V position and JP6 LDO- to the -12V position.
 9. Turn on and set PS1 to 15V.
 10. Repeat steps 3 through 5.
 11. Set the JP5 LDO+ jumper to the 24V position and JP6 LDO- to the -24V position.
 12. Turn on and set PS1 to 32V.
 13. Repeat steps 3 through 6.
 14. Turn on and set PS1 to 12V.
 15. Slowly increase the load on V_{OUT} to -100mA and observe the output ripple and output voltage on V_{OUT} .
 16. Set the load on V_{OUT} to 0mA.
 17. Change the JP3 MODE jumper from Burst Mode operation to constant-frequency mode and repeat steps 14 and 15.
 18. Change the JP4 FREQ jumper from 500kHz to 200kHz, then slowly increase the load on V_{OUT} from 0mA to -50mA and observe the output ripple and output voltage on V_{OUT} .
 19. Set the load on V_{OUT} to 0mA.
 20. Change the JP4 FREQ jumper from 200kHz to 50kHz. Slowly increase the load on V_{OUT} from 0mA to -10mA and observe the output ripple and output voltage on V_{OUT} .
- Figures 4 and 5 illustrate how the efficiency varies with load current in Burst Mode operation and in constant-frequency mode operation.

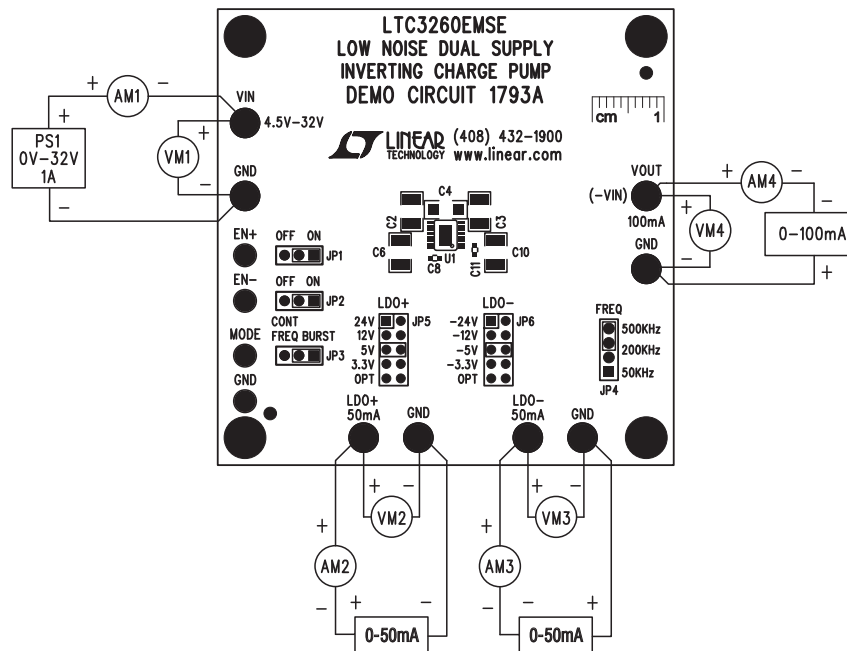

Figure 1. Proper Measurement Equipment Setup for DC1793A

QUICK START PROCEDURE

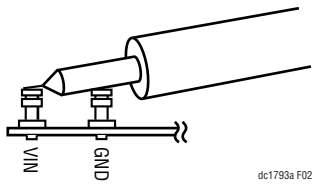
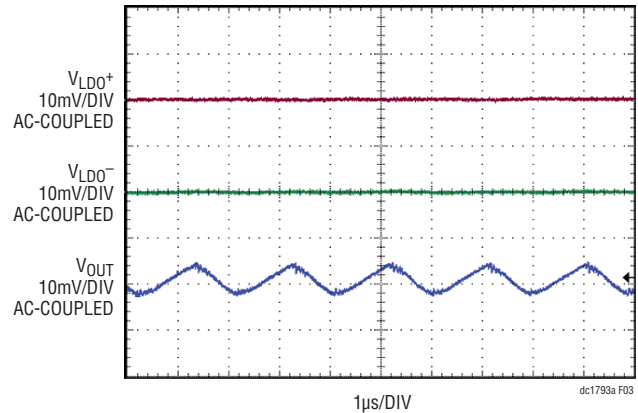

Figure 2. Measuring Input or Output Ripple



$V_{IN} = 15V$ $f_{OSC} = 500kHz$
 $V_{LDO+} = 12V$ $I_{LDO+} = 50mA$
 $V_{LDO-} = -12V$ $I_{LDO-} = -50mA$

Figure 3. LDO Rejection of V_{OUT} Ripple

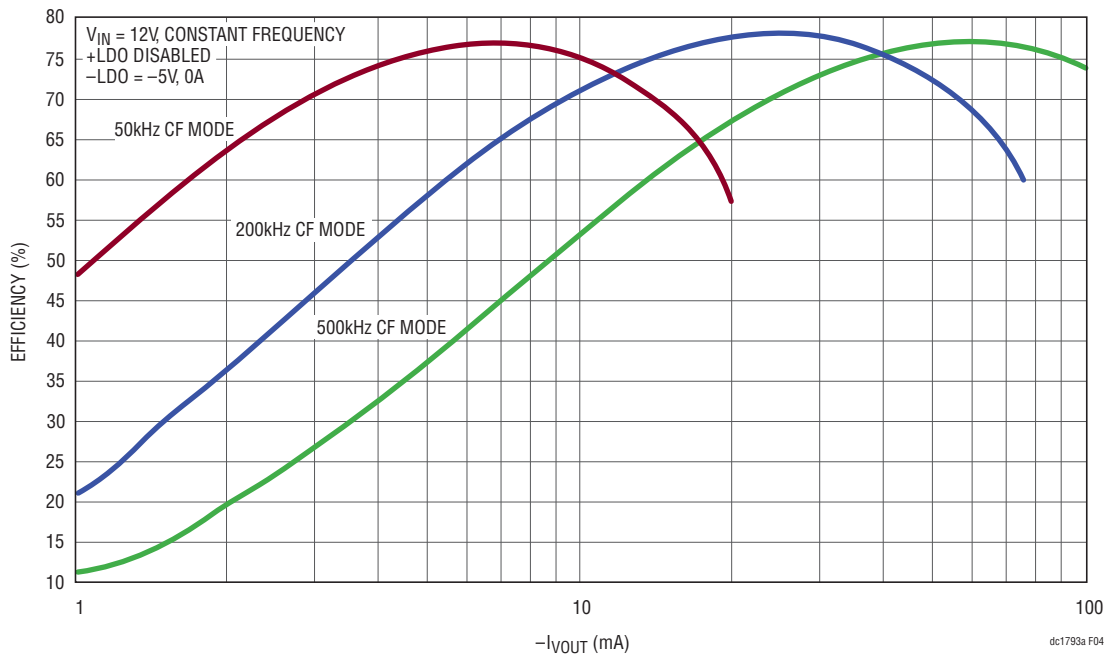

Figure 4. V_{IN} to V_{OUT} Constant-Frequency Mode Operation Efficiency

QUICK START PROCEDURE

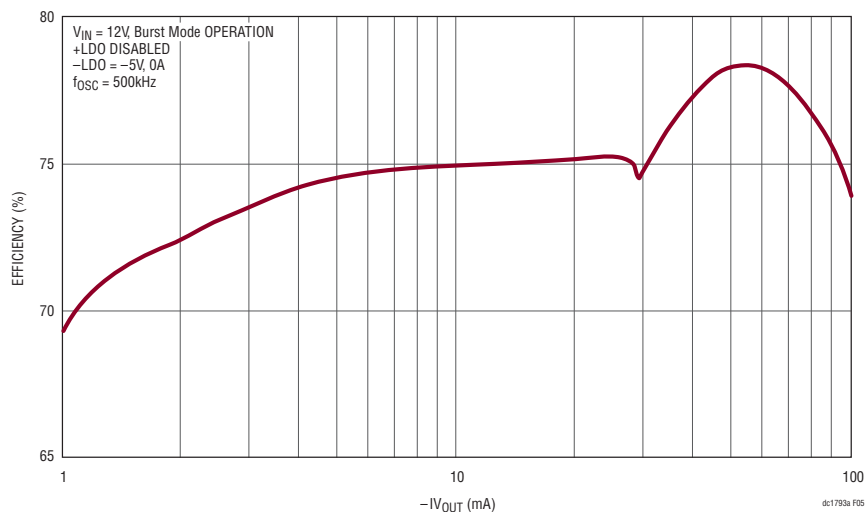

Figure 5. V_{IN} to V_{OUT} Burst Mode Operation Efficiency

PARTS LIST

ITEM	QTY	REFERENCE	PART DESCRIPTION	MANUFACTURER/PART NUMBER
Required Circuit Components				
1	4	C2, C3, C6, C10	CAP, CER, 10 μ F, 50V, X7S, 10%, 1210	TDK, C3225X7S1H106K
2	1	C4	CAP, CER, 1 μ F, 50V, X7R, 10%, 1206	MURATA, GRM31MR71H105KA88
3	2	R11, R18	RES, 100k, 1/16W, 1%, 0402, SMD	VISHAY, CRCW0402100KFKED
4	1	U1	LOW NOISE DUAL-SUPPLY INVERTING CHARGE PUMP	LINEAR TECHNOLOGY, LTC3260EMSE#PBF
Additional Demo Board Circuit Components				
5	1	C1	CAP, CER, 4.7 μ F, 50V, X7R, 10%, 1210	MURATA, GRM32ER71H475KA88L
6	0	C5, C7, C9 (OPT)	CAP, CER, 0603, 50V	OPT
7	2	C8, C11	CAP, CER, 0.01 μ F, 25V, X7R, 10%, 0402	MURATA, GRM155R71E103KA01D
8	3	R1, R8, R10	RES, 1M Ω , 1/16W, 5%, 0402, SMD	VISHAY, CRCW04021M00JNED
9	2	R2, R13	RES, 1.91M Ω , 1/16W, 1%, 0402, SMD	VISHAY, CRCW04021M91FKED
10	2	R3, R14	RES, 909k, 1/16W, 1%, 0402, SMD	VISHAY, CRCW0402909KFKED
11	2	R5, R16	RES, 174k, 1/16W, 1%, 0402, SMD	VISHAY, CRCW0402174KFKED
12	0	R6, R17 (OPT)	RES, 0402, SMD	OPT
13	3	R7, R9, R12	RES, 1k, 1/16W, 5%, 0402, SMD	VISHAY, CRCW04021K00FKED
14	1	R19	RES, 1M Ω , 1/16W, 1%, 0402, SMD	VISHAY, CRCW04021M00FKED
15	1	R20	RES, 200k, 1/16W, 1%, 0402, SMD	VISHAY, CRCW0402200KFKED
Hardware: For Demo Board Only				
17	3	JP1-JP3	HEADER, 3 PIN, 1 ROW, 0.079"	SAMTEC, TMM-103-02-L-S
18	1	JP4	HEADER, 4 PIN, 1 ROW, 0.079"	SAMTEC, TMM-104-02-L-S
19	2	JP5, JP6	HEADER, 2x5 PINS, 2mm	SAMTEC, TMM-105-02-L-D
20	6	JP1-JP6	SHUNT, 2mm	SAMTEC, 2SN-KB-G
21	8	E1, E2, E7-E12	TP, TURRET, 0.094", PBF	MILL-MAX, 2501-2-00-80-00-00-07-0
22	4	E3-E6	TURRET, 0.061", DIA	MILL-MAX, 2308-2-00-80-00-00-07-0

dc1793afa

SCHEMATIC DIAGRAM

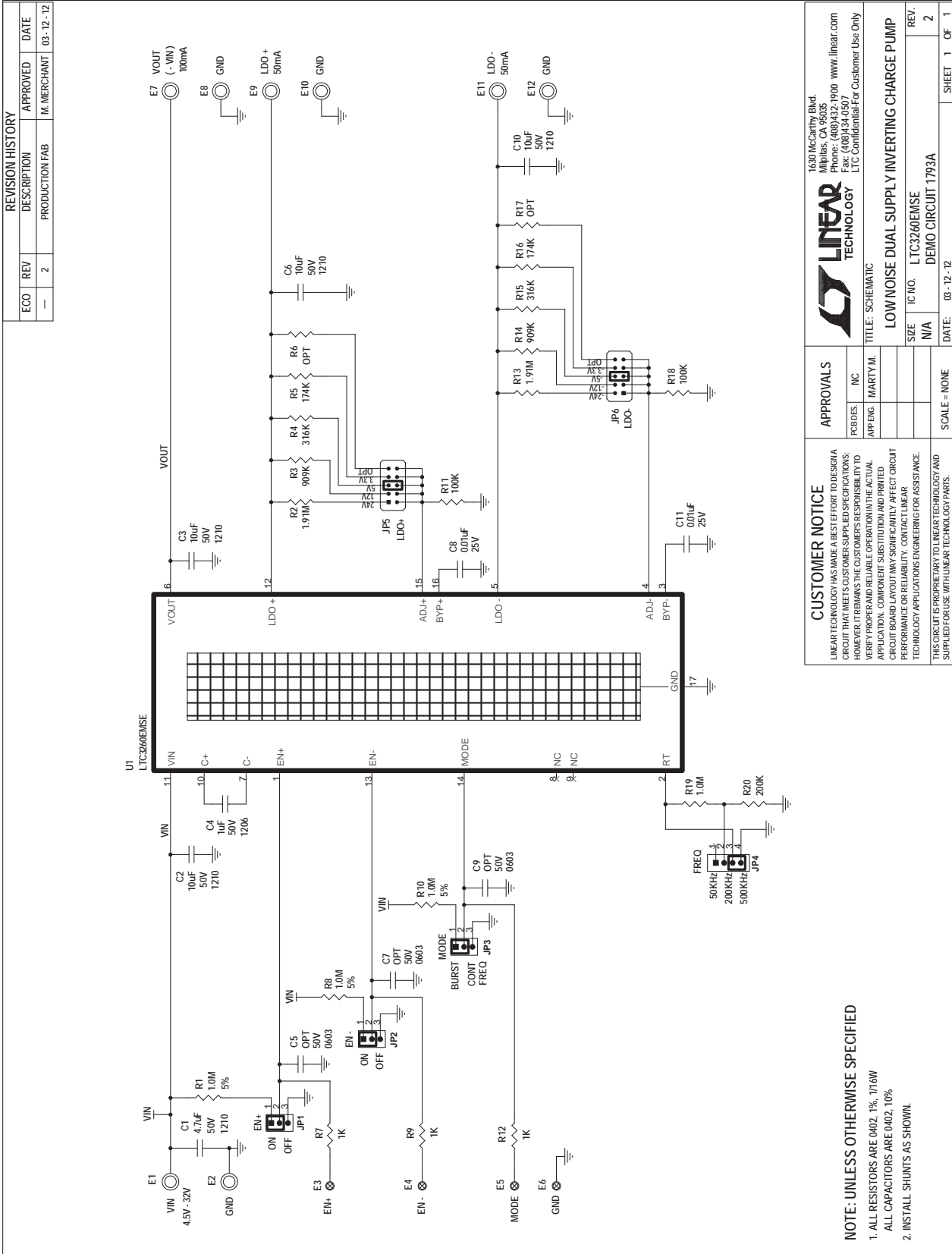

Figure 6. LTC3260EMSE Low Noise Dual Supply Inverting Charge Pump

DEMO MANUAL DC1793A

DEMONSTRATION BOARD IMPORTANT NOTICE

Linear Technology Corporation (LTC) provides the enclosed product(s) under the following **AS IS** conditions:

This demonstration board (DEMO BOARD) kit being sold or provided by Linear Technology is intended for use for **ENGINEERING DEVELOPMENT OR EVALUATION PURPOSES ONLY** and is not provided by LTC for commercial use. As such, the DEMO BOARD herein may not be complete in terms of required design-, marketing-, and/or manufacturing-related protective considerations, including but not limited to product safety measures typically found in finished commercial goods. As a prototype, this product does not fall within the scope of the European Union directive on electromagnetic compatibility and therefore may or may not meet the technical requirements of the directive, or other regulations.

If this evaluation kit does not meet the specifications recited in the DEMO BOARD manual the kit may be returned within 30 days from the date of delivery for a full refund. **THE FOREGOING WARRANTY IS THE EXCLUSIVE WARRANTY MADE BY THE SELLER TO BUYER AND IS IN LIEU OF ALL OTHER WARRANTIES, EXPRESSED, IMPLIED, OR STATUTORY, INCLUDING ANY WARRANTY OF MERCHANTABILITY OR FITNESS FOR ANY PARTICULAR PURPOSE. EXCEPT TO THE EXTENT OF THIS INDEMNITY, NEITHER PARTY SHALL BE LIABLE TO THE OTHER FOR ANY INDIRECT, SPECIAL, INCIDENTAL, OR CONSEQUENTIAL DAMAGES.**

The user assumes all responsibility and liability for proper and safe handling of the goods. Further, the user releases LTC from all claims arising from the handling or use of the goods. Due to the open construction of the product, it is the user's responsibility to take any and all appropriate precautions with regard to electrostatic discharge. Also be aware that the products herein may not be regulatory compliant or agency certified (FCC, UL, CE, etc.).

No License is granted under any patent right or other intellectual property whatsoever. **LTC assumes no liability for applications assistance, customer product design, software performance, or infringement of patents or any other intellectual property rights of any kind.**

LTC currently services a variety of customers for products around the world, and therefore this transaction **is not exclusive**.

Please read the DEMO BOARD manual prior to handling the product. Persons handling this product must have electronics training and observe good laboratory practice standards. **Common sense is encouraged.**

This notice contains important safety information about temperatures and voltages. For further safety concerns, please contact a LTC application engineer.

Mailing Address:

Linear Technology
1630 McCarthy Blvd.
Milpitas, CA 95035

Copyright © 2004, Linear Technology Corporation

X-ON Electronics

Largest Supplier of Electrical and Electronic Components

Click to view similar products for [Power Management IC Development Tools](#) category:

Click to view products by [Analog Devices](#) manufacturer:

Other Similar products are found below :

[EVAL-ADM1168LQEBZ](#) [EVB-EP5348UI](#) [MIC23451-AAAYFL EV](#) [MIC5281YMME EV](#) [DA9063-EVAL](#) [ADP122-3.3-EVALZ](#) [ADP130-0.8-EVALZ](#) [ADP130-1.2-EVALZ](#) [ADP130-1.5-EVALZ](#) [ADP130-1.8-EVALZ](#) [ADP1714-3.3-EVALZ](#) [ADP1716-2.5-EVALZ](#) [ADP1740-1.5-EVALZ](#) [ADP1752-1.5-EVALZ](#) [ADP1828LC-EVALZ](#) [ADP1870-0.3-EVALZ](#) [ADP1871-0.6-EVALZ](#) [ADP1873-0.6-EVALZ](#) [ADP1874-0.3-EVALZ](#) [ADP1882-1.0-EVALZ](#) [ADP199CB-EVALZ](#) [ADP2102-1.25-EVALZ](#) [ADP2102-1.875EVALZ](#) [ADP2102-1.8-EVALZ](#) [ADP2102-2-EVALZ](#) [ADP2102-3-EVALZ](#) [ADP2102-4-EVALZ](#) [ADP2106-1.8-EVALZ](#) [ADP2147CB-110EVALZ](#) [AS3606-DB](#) [BQ24010EVM](#) [BQ24075TEVM](#) [BQ24155EVM](#) [BQ24157EVM-697](#) [BQ24160EVM-742](#) [BQ24296MEVM-655](#) [BQ25010EVM](#) [BQ3055EVM](#) [NCV891330PD50GEVB](#) [ISLUSBI2CKIT1Z](#) [LM2744EVAL](#) [LM2854EVAL](#) [LM3658SD-AEV/NOPB](#) [LM3658SDEV/NOPB](#) [LM3691TL-1.8EV/NOPB](#) [LM4510SDEV/NOPB](#) [LM5033SD-EVAL](#) [LP38512TS-1.8EV](#) [EVAL-ADM1186-1MBZ](#) [EVAL-ADM1186-2MBZ](#)