

## DESCRIPTION

Demonstration circuit 1926A features the LTC4353, a dual low voltage ideal diode controller, in a typical 12A application. The LTC4353 creates two near-ideal diodes using external N-channel MOSFETs thereby replacing high power Schottky diodes and their associated heat sinks. Ideal diodes enable low loss power ORing and supply holdup applications.

**Design files for this circuit board are available at <http://www.linear.com/demo>**

LT, LT, LTC, LTM, Linear Technology and the Linear logo are registered trademarks of Linear Technology Corporation. All other trademarks are the property of their respective owners.

## PERFORMANCE SUMMARY

Specifications are at  $T_A = 25^\circ\text{C}$

SYMBOL	PARAMETER	CONDITIONS	MIN	TYP	MAX	UNITS
$V_{IN}$	$V_{IN1}$ and $V_{IN2}$ Input Voltage Operating Range	With External $V_{CC}$ Supply	2.9 0		18 $V_{CC}$	V
$V_{CC(EXT)}$	$V_{CC}$ External Supply Operating Range	$V_{IN1}, V_{IN2} \leq V_{CC}$	2.9		6.0	V
$V_{CC(REG)}$	$V_{CC}$ Regulated Voltage		4.5	5	5.5	V
$V_{CC(UVLO)}$	$V_{CC}$ Undervoltage Lockout Threshold	$V_{CC}$ Rising	2.3	2.55	2.7	V
$V_{FR}$	Forward Regulation Voltage ( $V_{IN} - V_{OUT}$ )	$V_{IN} = 1.2V, V_{CC} = 5V$ $V_{IN} = 12V$	2 2	12 25	25 50	mV mV
$\Delta V_{GATE}$	MOSFET Gate Drive ( $GATE - V_{IN}$ )	$V_{FWD} = 0.2V; I = 0, -1\mu A$ ; Highest $V_{IN} = 12V$ $V_{FWD} = 0.2V; I = 0, -1\mu A$ ; Highest $V_{IN} = 2.9V$	10 4.5	12 7	14 9	V V
$I_{GATE}$	GATE1, GATE2 Fast Pull-Up Current GATE1, GATE2 Fast Pull-Down Current GATE1, GATE2 Off Pull-Down Current	$V_{FWD} = 0.4V, \Delta V_{GATE} = 0, CPO = 17V$ $V_{FWD} = -0.8V, \Delta V_{GATE} = 5V$ , Corresponding $\overline{EN} = 1V, \Delta V_{GATE} = 2.5V$	-0.9 0.9 65	-1.4 1.4 110	-1.9 1.9 160	A A $\mu A$
$V_{EN(TH)}$	$\overline{EN1}, \overline{EN2}$ Threshold Voltage	$\overline{EN}$ Falling	580	600	620	mV
$\Delta V_{GATE(ON)}$	MOSFET On-Detect Threshold ( $GATE - V_{IN}$ )	$\overline{ONST}$ Pulls Low	0.28	0.7	1.1	V
$I_{OUT}$	Maximum Continuous Load Current for Si4126DY	Limited by 0.6W power dissipation with maximum voltage regulation 50mV			12	A

## OPERATING PRINCIPLES

The LTC4353 regulates the forward voltage drop across the external MOSFETs to ensure smooth current transfer in diode-OR applications. A fast turn-on reduces the load voltage droop during supply switchover. If the input supply fails or is shorted, a fast turn-off minimizes reverse current transients. The controller operates with rail voltages from 2.9V to 18V. Operation with rail voltages below 2.9V requires an additional supply of 2.9V to 6.0V at the  $V_{CC}$  pin.

The LTC4353 indicates the on state of each MOSFET with the  $\overline{ONST1}$  and  $\overline{ONST2}$  pin signals, when the gate voltage is at least 0.7V higher than  $V_{IN}$ . Two enable pins ( $\overline{EN1}, \overline{EN2}$ ) allow activating or blocking each MOSFET channel individually.

Green LEDs ON1 and ON2 indicate the state of the associated MOSFET.

## QUICK START PROCEDURE

Demonstration circuit DC1926A is easy to set up to evaluate the performance of the LTC4353. Controller performance can be verified over the full operating range of 2.9V to 18V.

The installed MOSFETs in the SO-8 package are located on the top side of the board. Provision is made on the bottom side for using an additional SO-8 MOSFET in parallel with the MOSFET on the top side. To extend current capability the unstuffed PCB footprint (bottom side) also supports the D2PAK package.

The DC1926A test includes two parts: Ideal Diode Test and Ideal Diode-ORing test.

### Ideal Diode Test

1. Connect a 12V power supply to  $V_{IN1}(+)$  and GND (-) of the DC1926A. Place a millivoltmeter between the input ( $V_{IN1}$ ) and output (OUT1) turrets (refer to the diagram of Figure 1). This is the controller regulation voltage. The regulation voltage should be in the range of 2mV to 50mV.
2. LED1 should be illuminated.
3. Repeat the test with the second channel ( $V_{IN2}$ , OUT2).
4. Record regulation voltage values.

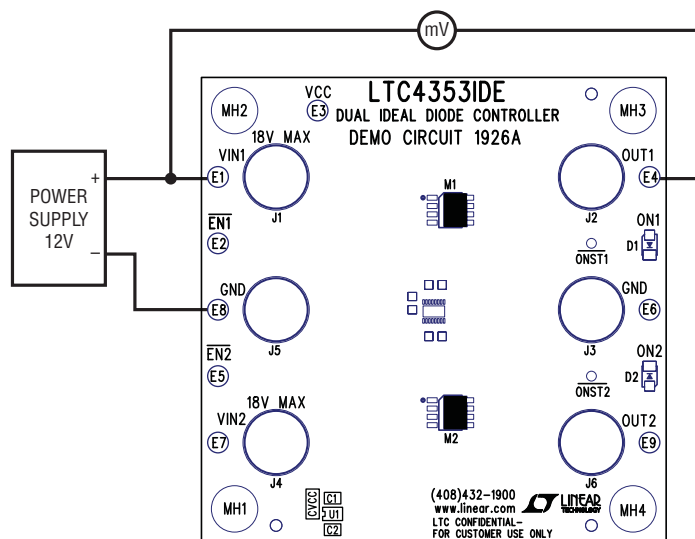

Figure 1. Ideal Diode Regulation Voltage Measurement

## QUICK START PROCEDURE

### Ideal Diode-ORing Test

1. Connect two identical power supplies adjusted to +12V to  $V_{IN1}$  and  $V_{IN2}$  inputs and provide a load to the parallel connected OUT1 and OUT2 turrets (refer to the diagram of Figure 2). The output load current should not exceed 12A for continuous operation.
2. The steady state operation of the Ideal Diode ORing circuit is defined by the following parameters:

$-V_{DS(ON)}$  is the voltage drop of the MOSFET  $R_{DS(ON)}$  under maximum load current. This is measured by using only the power supply of the channel under test with the load connected and the measurement between  $V_{IN}$  and OUTPUT. Record  $V_{DS(ON)}$ ;

$-\Delta V_{REG}$  is the absolute value of the differences in voltage recorded in step 4 above;

$-\Delta_{SUPPLIES}$  is the difference of the power supply output voltages.

3. Adjust the voltage of the power supply connected to  $[\Delta_{SUPPLIES} - \Delta V_{REG}] > V_{DS(ON)} > 0$ . The power supply will provide all of the current to the load. The LED associated with this channel will be illuminated
4. Adjust the voltage of the power supply to  $V_{DS(ON)} > [\Delta_{SUPPLIES} - \Delta V_{REG}] > 0$ . The supply with the higher voltage will supply most of the current to the load, while the supply with the lower voltage will supply less current. Both LEDs diodes will be illuminated because both channels are providing current to the load.

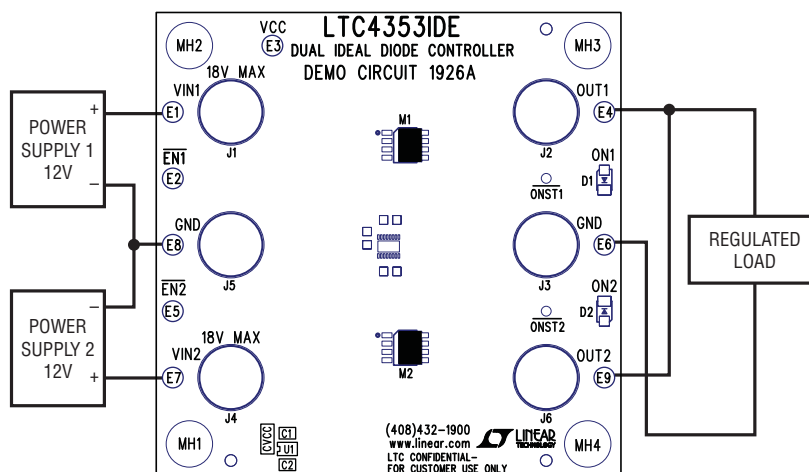

Figure 2. Ideal Diode ORing Operation

# DEMO MANUAL DC1926A

---

## PARTS LIST

ITEM	QTY	REFERENCE	PART DESCRIPTION	MANUFACTURER/PART NUMBER
1	1	CVCC	Cap., X7R, 0.1µF 50V 10%, 0805	AVX, 08055C104KAT2A
2	2	C1, C2	Cap., X7R, 0.056µF 50V 10%, 0805	AVX, 08055C563KAT2A
3	2	D1, D2	LED, GREEN	Panasonic, LN1351C-TR
4	2	D3, D4	Diode, Current Limiting, 3.2V, SOD-80	Central Semi. Corp., CMJ3500-TR
5	9	E1-E9	Turret, 0.064"	Mill Max, 2308-2-00-80-00-00-07-0
6	6	J1, J2, J3, J4, J5, J6	Connector, Banana Jack	Keystone, 575-4
7	2	M1, M2	MOSFET, N-Channel, 30V, SO8-POWERPAK	Vishay, Si4126DY
8	2	R3, R5	Resistor, Chip 10k 0.1W 5%,0805	Vishay, CRCW080510K0JNEA
9	0	R4, R6	Resistor, 0805	TBD
10	1	U1	I.C., Dual Ideal Diode, DFN16DE-4 × 3	Linear Technology, LTC4353IDE

**SCHEMATIC DIAGRAM**

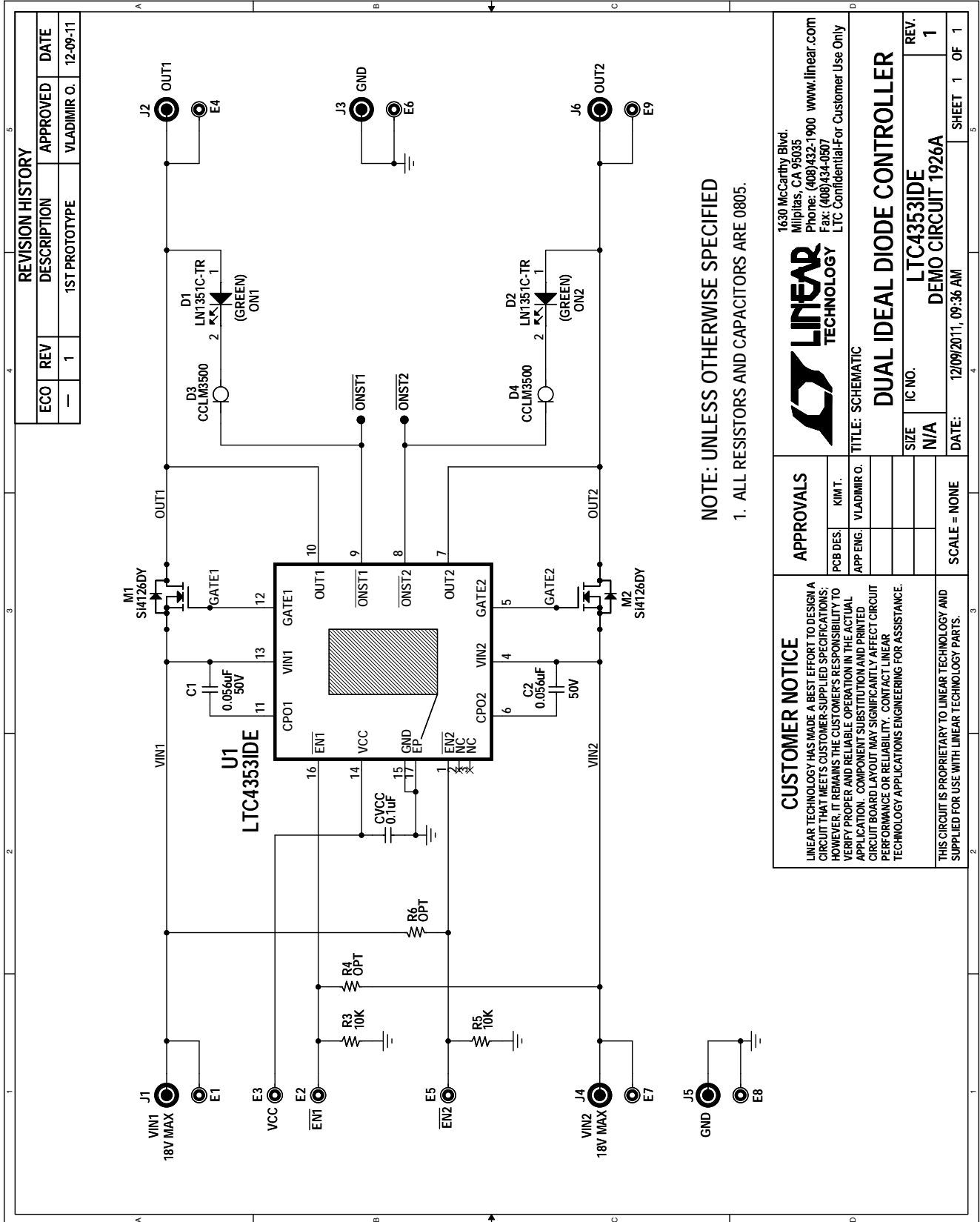

**CUSTOMER NOTICE**

LINEAR TECHNOLOGY HAS MADE A BEST EFFORT TO DESIGN A CIRCUIT THAT MEETS CUSTOMER-SUPPLIED SPECIFICATIONS; HOWEVER, IT REMAINS THE CUSTOMER'S RESPONSIBILITY TO VERIFY PROPER AND RELIABLE OPERATION IN THE ACTUAL APPLICATION. COMPONENT SUBSTITUTION AND PRINTED CIRCUIT BOARD LAYOUT MAY SIGNIFICANTLY AFFECT CIRCUIT PERFORMANCE OR RELIABILITY. CONTACT LINEAR TECHNOLOGY APPLICATIONS ENGINEERING FOR ASSISTANCE.

THIS CIRCUIT IS PROPRIETARY TO LINEAR TECHNOLOGY AND SUPPLIED FOR USE WITH LINEAR TECHNOLOGY PARTS.

**APPROVALS**

PCB DES.	
APP ENG.	VLADIMIR O.
KIMT.	
SCALE	NONE

**LINEAR TECHNOLOGY**

1630 McCarthy Blvd.  
Milpitas, CA 95035  
Phone: (408)432-1900 www.linear.com  
Fax: (408)434-0507  
LTC Confidential-For Customer Use Only

TITLE: SCHEMATIC

**DUAL IDEAL DIODE CONTROLLER**

IC NO.	LTC4353IDE	REV.	1
SIZE	N/A	DATE:	12/09/2011, 09:36 AM
SHEET 1		OF 1	

# DEMO MANUAL DC1926A

---

## DEMONSTRATION BOARD IMPORTANT NOTICE

Linear Technology Corporation (LTC) provides the enclosed product(s) under the following **AS IS** conditions:

This demonstration board (DEMO BOARD) kit being sold or provided by Linear Technology is intended for use for **ENGINEERING DEVELOPMENT OR EVALUATION PURPOSES ONLY** and is not provided by LTC for commercial use. As such, the DEMO BOARD herein may not be complete in terms of required design-, marketing-, and/or manufacturing-related protective considerations, including but not limited to product safety measures typically found in finished commercial goods. As a prototype, this product does not fall within the scope of the European Union directive on electromagnetic compatibility and therefore may or may not meet the technical requirements of the directive, or other regulations.

If this evaluation kit does not meet the specifications recited in the DEMO BOARD manual the kit may be returned within 30 days from the date of delivery for a full refund. **THE FOREGOING WARRANTY IS THE EXCLUSIVE WARRANTY MADE BY THE SELLER TO BUYER AND IS IN LIEU OF ALL OTHER WARRANTIES, EXPRESSED, IMPLIED, OR STATUTORY, INCLUDING ANY WARRANTY OF MERCHANTABILITY OR FITNESS FOR ANY PARTICULAR PURPOSE. EXCEPT TO THE EXTENT OF THIS INDEMNITY, NEITHER PARTY SHALL BE LIABLE TO THE OTHER FOR ANY INDIRECT, SPECIAL, INCIDENTAL, OR CONSEQUENTIAL DAMAGES.**

The user assumes all responsibility and liability for proper and safe handling of the goods. Further, the user releases LTC from all claims arising from the handling or use of the goods. Due to the open construction of the product, it is the user's responsibility to take any and all appropriate precautions with regard to electrostatic discharge. Also be aware that the products herein may not be regulatory compliant or agency certified (FCC, UL, CE, etc.).

No License is granted under any patent right or other intellectual property whatsoever. **LTC assumes no liability for applications assistance, customer product design, software performance, or infringement of patents or any other intellectual property rights of any kind.**

LTC currently services a variety of customers for products around the world, and therefore this transaction **is not exclusive**.

**Please read the DEMO BOARD manual prior to handling the product.** Persons handling this product must have electronics training and observe good laboratory practice standards. **Common sense is encouraged.**

This notice contains important safety information about temperatures and voltages. For further safety concerns, please contact a LTC application engineer.

Mailing Address:

Linear Technology  
1630 McCarthy Blvd.  
Milpitas, CA 95035

Copyright © 2004, Linear Technology Corporation

## X-ON Electronics

Largest Supplier of Electrical and Electronic Components

*Click to view similar products for [Power Management IC Development Tools](#) category:*

*Click to view products by [Analog Devices](#) manufacturer:*

Other Similar products are found below :

[EVAL-ADM1168LQEBZ](#) [EVB-EP5348UI](#) [MIC23451-AAAYFL EV](#) [MIC5281YMME EV](#) [DA9063-EVAL](#) [ADP122-3.3-EVALZ](#) [ADP130-0.8-EVALZ](#) [ADP130-1.2-EVALZ](#) [ADP130-1.5-EVALZ](#) [ADP130-1.8-EVALZ](#) [ADP1714-3.3-EVALZ](#) [ADP1716-2.5-EVALZ](#) [ADP1740-1.5-EVALZ](#) [ADP1752-1.5-EVALZ](#) [ADP1828LC-EVALZ](#) [ADP1870-0.3-EVALZ](#) [ADP1871-0.6-EVALZ](#) [ADP1873-0.6-EVALZ](#) [ADP1874-0.3-EVALZ](#) [ADP1882-1.0-EVALZ](#) [ADP199CB-EVALZ](#) [ADP2102-1.25-EVALZ](#) [ADP2102-1.875EVALZ](#) [ADP2102-1.8-EVALZ](#) [ADP2102-2-EVALZ](#) [ADP2102-3-EVALZ](#) [ADP2102-4-EVALZ](#) [ADP2106-1.8-EVALZ](#) [ADP2147CB-110EVALZ](#) [AS3606-DB](#) [BQ24010EVM](#) [BQ24075TEVM](#) [BQ24155EVM](#) [BQ24157EVM-697](#) [BQ24160EVM-742](#) [BQ24296MEVM-655](#) [BQ25010EVM](#) [BQ3055EVM](#) [NCV891330PD50GEVB](#) [ISLUSBI2CKIT1Z](#) [LM2744EVAL](#) [LM2854EVAL](#) [LM3658SD-AEV/NOPB](#) [LM3658SDEV/NOPB](#) [LM3691TL-1.8EV/NOPB](#) [LM4510SDEV/NOPB](#) [LM5033SD-EVAL](#) [LP38512TS-1.8EV](#) [EVAL-ADM1186-1MBZ](#) [EVAL-ADM1186-2MBZ](#)