

DESCRIPTION

Demonstration circuit 1986A is an I²C μModule[®] Isolator featuring the LTM2892-I. The demo circuit operates from external supply voltages on V_{CC1}, V_{L1}, V_{CC2}, and V_{L2}. It communicates all necessary signaling across the isolation barrier through LTC's Isolator[™] μModule Technology.

Design files for this circuit board are available at <http://www.linear.com/demo>

LT, LT, LTC, LTM, Linear Technology, the Linear logo and μModule are registered trademarks and Isolator is a trademark of Linear Technology Corporation. All other trademarks are the property of their respective owners.

PERFORMANCE SUMMARY

Specifications are at T_A = 25°C

SYMBOL	PARAMETER	CONDITIONS	MIN	TYP	MAX	UNITS
V _{CC1} , V _{CC2}	Input Supply Range		3.0		5.5	V
V _{L1} , V _{L2}	Logic Supply Range		3.0		5.5	V
f _{MAX}	Maximum Data Rate	INx → OUTx, C _L = 15pF	20			MHz
		I ² C Communication	400			kHz
V _{IORM}	Maximum Working Insulation Voltage	GND1 to GND2	850			V _{DC}
			600			V _{RMS}
	Common Mode Transient Immunity		50			kV/μs

OPERATING PRINCIPLES

The LTM2892-I requires two to four external power supplies for operation, one for power and one for the signal interface, on each side of the isolation barrier. The logic supplies may be tied to the input supplies. Isolation is maintained by the separation of GND1 and GND2 where significant operating voltages and transients can exist without affecting the operation of the LTM2892-I. The ON1 and/or ON2 pins enable or shut down the LTM2892-I, both must be driven to their respective logic supply voltage for proper operation. All I²C or digital signals are referenced to the logic supply pins V_{L1} or V_{L2}.

I²C signaling does not require any additional components. The demo board includes pull-up resistors on SDA1 and SCLIN. SCLOUT and SDA2 do not require external pull-ups, SCLOUT is a push-pull output and SDA2 is pulled high through an integral current source within the LTM2892-I.

Do not use external pull-up resistors or current sources on SCLOUT or SDA2.

I²C signaling is configured by defining the LTM2892-I pins as follows:

Logic Side: SCLIN = SCL(IN), and SDA1 = SDA(IN).

Isolated Side: SCLOUT = SCL(OUT), SDA2 = SDA(OUT).

Reference Figure 1 for schematic representation.

No special precautions are required for low RF emissions. EMI performance is shown in Figure 2, measured using a gigahertz transverse electromagnetic (GTEM) cell and method detailed in IEC 61000-4-20, Testing and Measurement Techniques – Emission and Immunity Testing in Transverse Electromagnetic Waveguides.

OPERATING PRINCIPLES

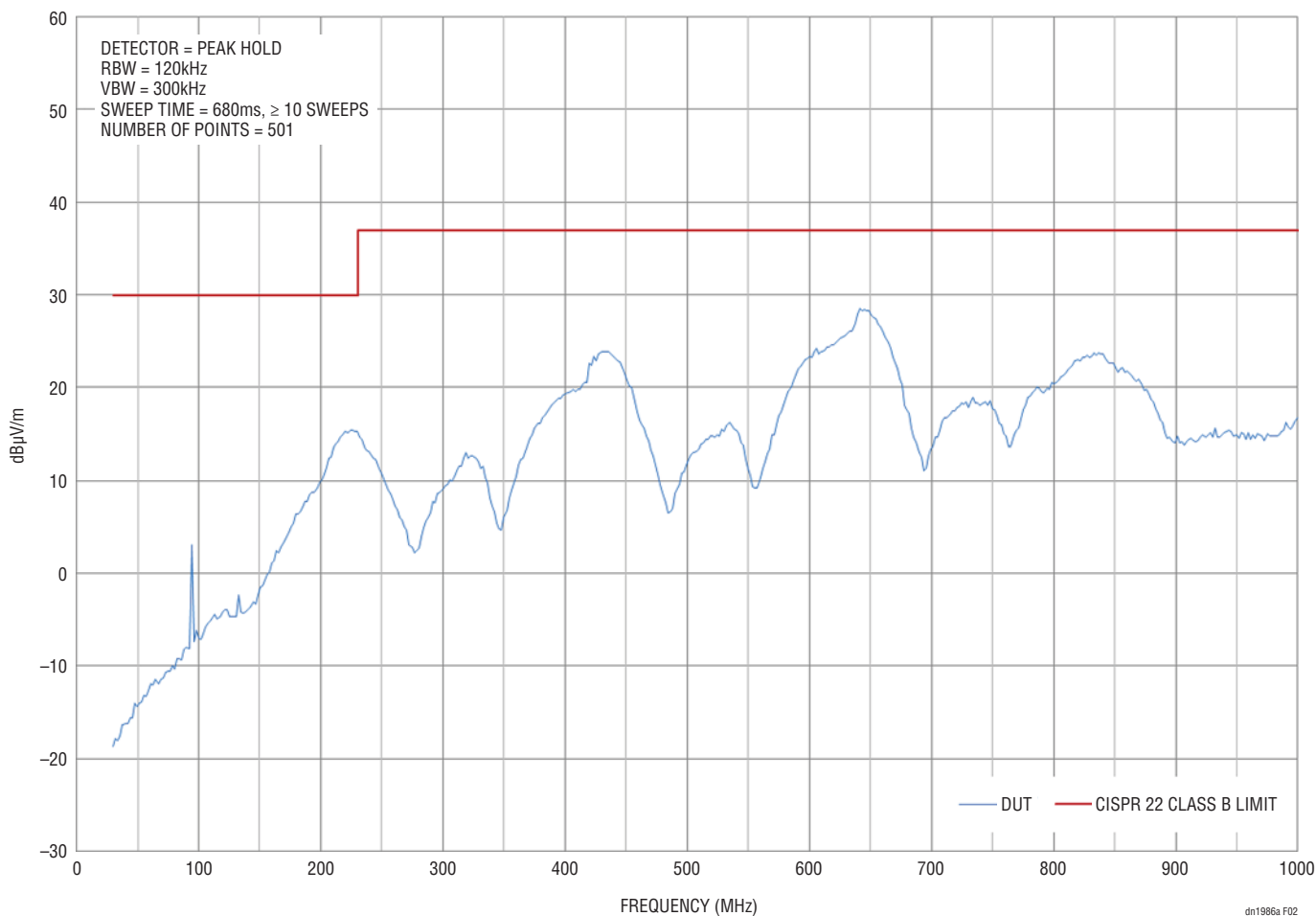
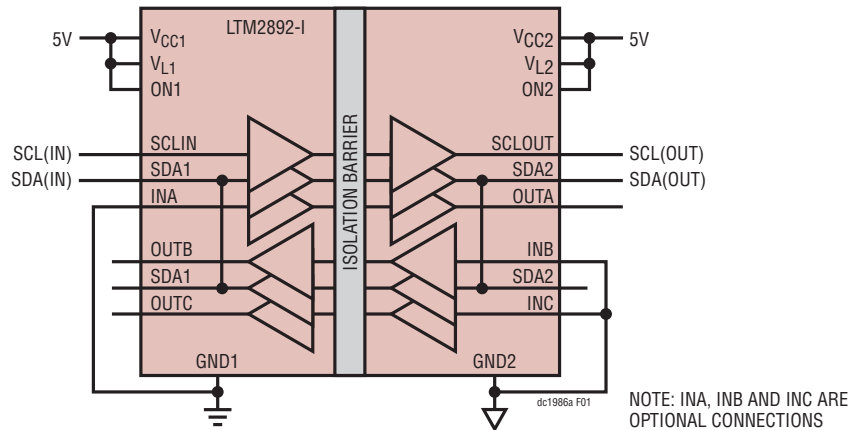

QUICK START PROCEDURE

Demonstration circuit 1986A is easy to set up and evaluate the performance of the LTM2892-I. Refer to Figure 3 for proper measurement equipment setup and follow the procedure below.

NOTE: When measuring the input or output voltage ripple or high speed signals, care must be taken to avoid a long ground lead on the oscilloscope probe.

1. Install jumpers as shown in Figure 3 and the schematic diagram.

2. With power off, connect the input power supplies to $V_{CC1} - GND1$ and $V_{CC2} - GND2$ as shown.

3. Turn on the power at the input.

NOTE: Make sure that the input voltage does not exceed 6V.

4. Configure jumpers or connect signals to turrets as appropriate. If a signal is connected to an input channel turret the associated channel jumper must be removed for proper operation.

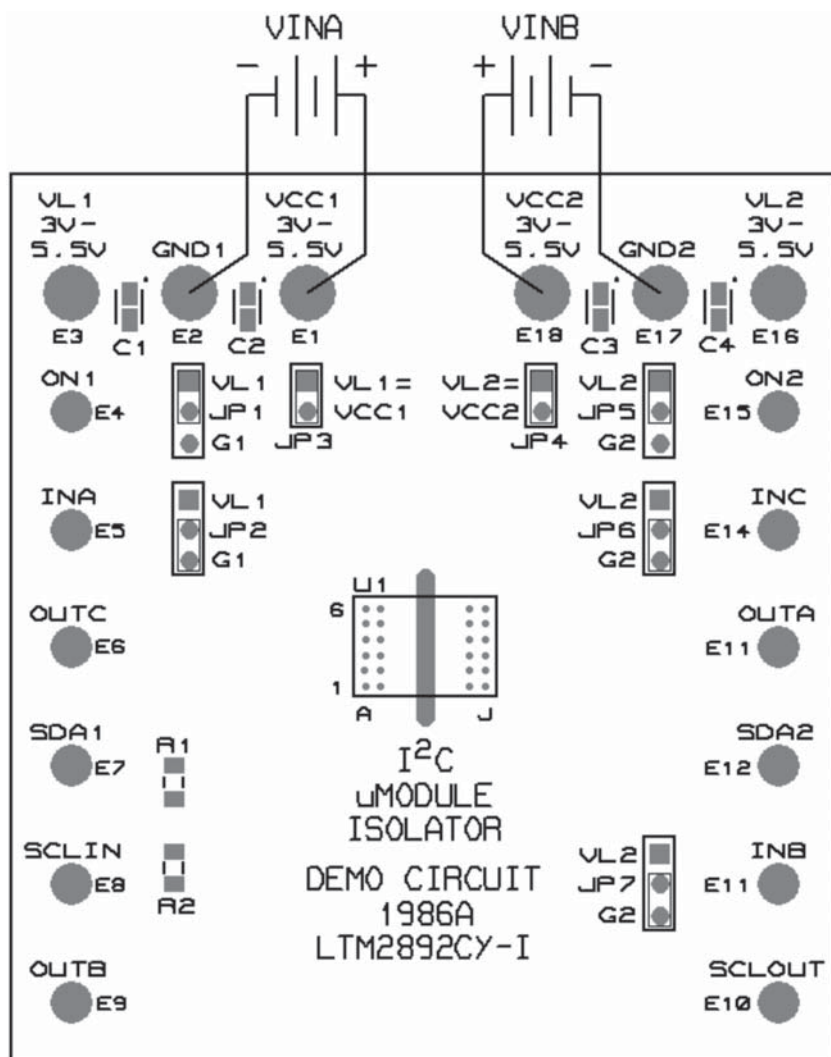
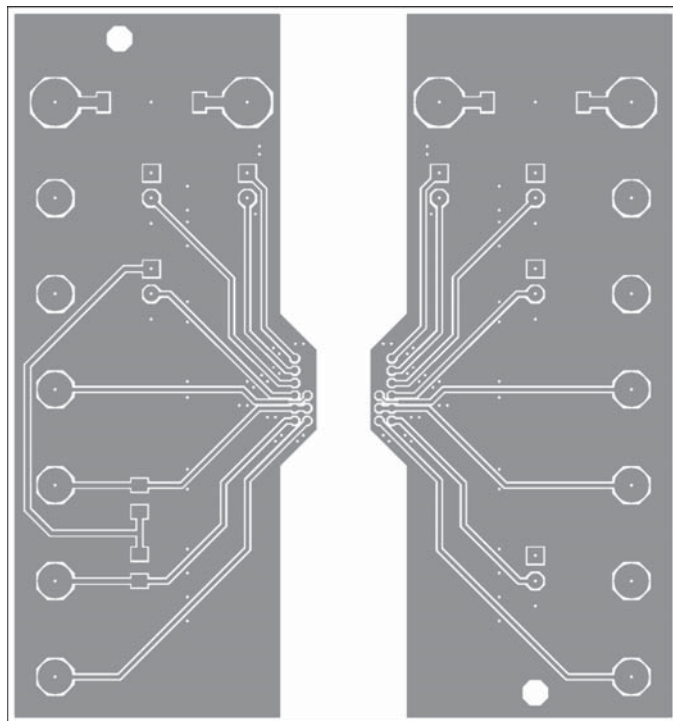
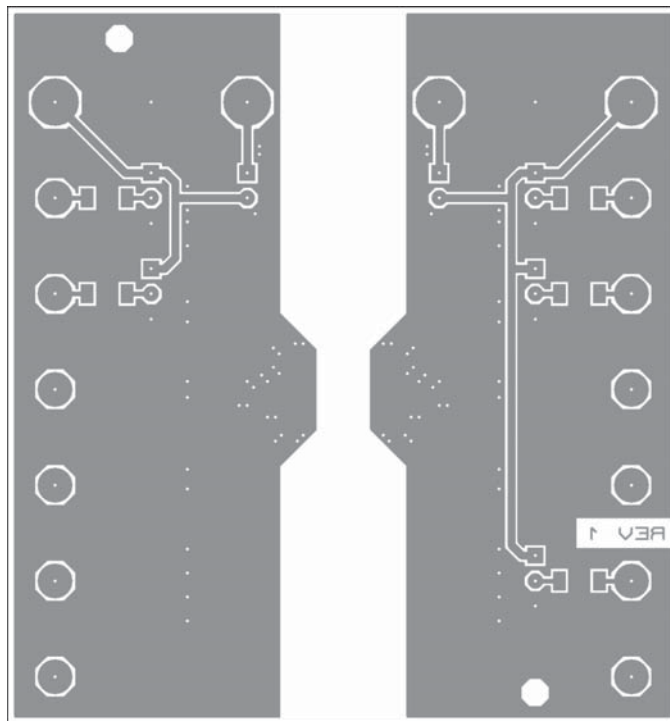

Figure 3. Demo Board Setup

PCB LAYOUT



Top Copper



Bottom Copper

PARTS LIST

ITEM	QTY	REFERENCE	PART DESCRIPTION	MANUFACTURER/PART NUMBER
Required Circuit Components				
1	1	U1	I.C., LTM2892CY-I	LINEAR LTM2892CY-I#PBF
Hardware: For Demo Board Only				
2	4	C1-4	CAP., TANT 4.7μF 10V 20% 0805	NICHICON F921A475MPA
3	12	E4-15	TURRET, 0.065"	MILL-MAX 2308-2-00-80-00-00-07-0
4	6	E1-3, E16-18	TURRET, 0.095"	MILL-MAX 2501-2-00-80-00-00-07-0
5	2	JP3-4	2mm SINGLE ROW HEADER, 2 X 1 PIN	SAMTEC TMM-102-02-L-S
6	5	JP1-2, JP5-7	2mm SINGLE ROW HEADER, 3 x 1 PIN	SAMTEC TMM-103-02-L-S
7	7	JP1-7	2mm SHUNT	SAMTEC 2SN-BK-G
8	2	R1-R2	RES., CHIP 4.7kΩ 5% 0805	VISHAY CRCW08054K70JNEA
9	5	R3-R7	RES., CHIP 100Ω 5% 1206	AAC CR18-101JM

SCHEMATIC DIAGRAM

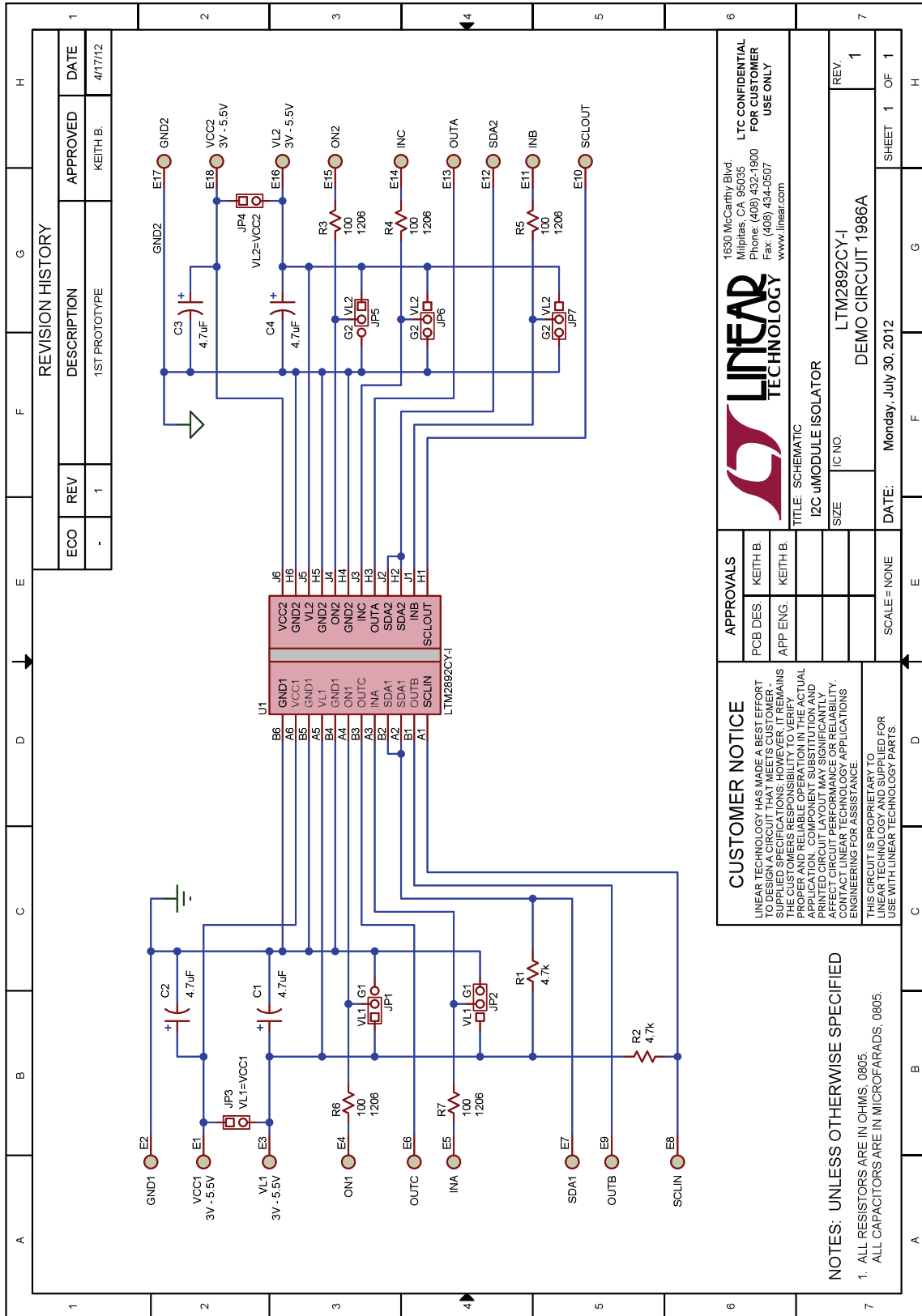

1630 McCarthy Blvd.
Milpitas, CA 95035
Phone: (408) 432-1900
Fax: (408) 434-0507
www.linear.com

LINEAR TECHNOLOGY

TITLE: SCHEMATIC
I2C iMODULE ISOLATOR

SIZE: IC NO. LTM2892CY-1
REV. 1

DATE: Monday, July 30, 2012
SHEET 1 OF 1

APPROVALS

PCB DES.	KEITH B.
APP ENG.	KEITH B.

SCALE = NONE

CUSTOMER NOTICE
LINEAR TECHNOLOGY HAS MADE A BEST EFFORT TO DESIGN A CIRCUIT THAT MEETS CUSTOMER-SUPPLIED SPECIFICATIONS; HOWEVER, IT REMAINS THE CUSTOMER'S RESPONSIBILITY TO OBTAIN PROPER AND RELIABLE OPERATION IN THE ACTUAL APPLICATION. COMPONENT SUBSTITUTION AND PRINTED CIRCUIT LAYOUT MAY SIGNIFICANTLY AFFECT CIRCUIT PERFORMANCE OR RELIABILITY. CUSTOMER TESTING AND APPLICATIONS ENGINEERING FOR ASSISTANCE.

THIS CIRCUIT IS PROPRIETARY TO LINEAR TECHNOLOGY AND IS NOT TO BE REPRODUCED OR USED FOR USE WITH LINEAR TECHNOLOGY PARTS.

NOTES: UNLESS OTHERWISE SPECIFIED
1. ALL RESISTORS ARE IN OHMS, 0805.
ALL CAPACITORS ARE IN MICROFARADS, 0805.



Information furnished by Linear Technology Corporation is believed to be accurate and reliable. However, no responsibility is assumed for its use. Linear Technology Corporation makes no representation that the interconnection of its circuits as described herein will not infringe on existing patent rights.

DEMO MANUAL DC1986A

DEMONSTRATION BOARD IMPORTANT NOTICE

Linear Technology Corporation (LTC) provides the enclosed product(s) under the following **AS IS** conditions:

This demonstration board (DEMO BOARD) kit being sold or provided by Linear Technology is intended for use for **ENGINEERING DEVELOPMENT OR EVALUATION PURPOSES ONLY** and is not provided by LTC for commercial use. As such, the DEMO BOARD herein may not be complete in terms of required design-, marketing-, and/or manufacturing-related protective considerations, including but not limited to product safety measures typically found in finished commercial goods. As a prototype, this product does not fall within the scope of the European Union directive on electromagnetic compatibility and therefore may or may not meet the technical requirements of the directive, or other regulations.

If this evaluation kit does not meet the specifications recited in the DEMO BOARD manual the kit may be returned within 30 days from the date of delivery for a full refund. **THE FOREGOING WARRANTY IS THE EXCLUSIVE WARRANTY MADE BY THE SELLER TO BUYER AND IS IN LIEU OF ALL OTHER WARRANTIES, EXPRESSED, IMPLIED, OR STATUTORY, INCLUDING ANY WARRANTY OF MERCHANTABILITY OR FITNESS FOR ANY PARTICULAR PURPOSE. EXCEPT TO THE EXTENT OF THIS INDEMNITY, NEITHER PARTY SHALL BE LIABLE TO THE OTHER FOR ANY INDIRECT, SPECIAL, INCIDENTAL, OR CONSEQUENTIAL DAMAGES.**

The user assumes all responsibility and liability for proper and safe handling of the goods. Further, the user releases LTC from all claims arising from the handling or use of the goods. Due to the open construction of the product, it is the user's responsibility to take any and all appropriate precautions with regard to electrostatic discharge. Also be aware that the products herein may not be regulatory compliant or agency certified (FCC, UL, CE, etc.).

No License is granted under any patent right or other intellectual property whatsoever. **LTC assumes no liability for applications assistance, customer product design, software performance, or infringement of patents or any other intellectual property rights of any kind.**

LTC currently services a variety of customers for products around the world, and therefore this transaction **is not exclusive**.

Please read the DEMO BOARD manual prior to handling the product. Persons handling this product must have electronics training and observe good laboratory practice standards. **Common sense is encouraged.**

This notice contains important safety information about temperatures and voltages. For further safety concerns, please contact a LTC application engineer.

Mailing Address:

Linear Technology
1630 McCarthy Blvd.
Milpitas, CA 95035

Copyright © 2004, Linear Technology Corporation

X-ON Electronics

Largest Supplier of Electrical and Electronic Components

Click to view similar products for [Interface Development Tools](#) category:

Click to view products by [Analog Devices](#) manufacturer:

Other Similar products are found below :

[DP130SSEVM](#) [ISO3086TEVM-436](#) [ADP5585CP-EVALZ](#) [CHA2066-99F](#) [AS8650-DB](#) [I2C-CPEV/NOPB](#) [ISO35TEVM-434](#) [416100120-3](#)
[XR18910ILEVB](#) [XR21B1421IL28-0A-EVB](#) [EVAL-ADM2491EEBZ](#) [MAXREFDES23DB#](#) [MAX9286COAXEVKIT#](#) [MAX3100EVKIT](#)
[MAX13235EEVKIT](#) [MAX14970EVKIT#](#) [XR21B1424IV64-0A-EVB](#) [CMOD232+](#) [MAX13042EEVKIT+](#) [MAX14838EVKIT#](#)
[MAXCAM705OV635AAA#](#) [MAX9205EVKIT](#) [DS100BR111AEVK/NOPB](#) [DC241C](#) [MAX9286RCARH3DB#](#) [MAX13035EEVKIT+](#)
[DC1794A](#) [SN65HVS885EVM](#) [EVB81112-A1](#) [DFR0257](#) [ZLR964122L](#) [ZLR88822L](#) [DC196A-B](#) [DC196A-A](#) [DC327A](#) [OM13585UL](#)
[MAX16972AGEEVKIT#](#) [MARS1-DEMO3-ADAPTER-GEVB](#) [MAX7315EVKIT+](#) [PIM511](#) [PIM536](#) [PIM517](#) [DEV-17512](#) [STR-](#)
[FUSB3307MPX-PPS-GEVK](#) [MAXREFDES177#](#) [EVAL-ADN4654EBZ](#) [MAX9275COAXEVKIT#](#) [MAX2202XEVKIT#](#)
[MAX13171EEVKIT+](#) [MAX7322EVKIT+](#)