

LTC5577 300MHz to 6GHz High Signal Level Active Downconverting Mixer

DESCRIPTION

Demonstration circuit DC2070A is optimized for evaluation of the LTC[®]5577 high signal level active downconverting mixer. Its RF input port is matched to 50Ω from 1.3GHz to 4.3GHz with 12dB return loss, and the LO port is matched to 50Ω from 930MHz to 4.1GHz with 10dB return loss. The RF and LO inputs are easily matched for higher or lower frequencies with simple external matching, as low as 350MHz and 300MHz, respectively. The low capacitance differential IF output is usable up to 1.5GHz. The LTC5577 active mixer is optimized for RF downconverting applications that require high input signal handling capability and wide bandwidth.

Design files for this circuit board are available at <http://www.linear.com/demo>

LT, LT, LTC, LTM, Linear Technology and the Linear logo are registered trademarks of Analog Devices, Inc. All other trademarks are the property of their respective owners.

ABSOLUTE MAXIMUM INPUT RATINGS

Supply Voltage (V_{CC} , IF^+ , IF^-)	4V
Enable Input Voltage (EN)	-0.3V to $V_{CC} + 0.3V$
LO Input Power (300MHz to 6GHz)	10dBm
LO Input DC Voltage	$\pm 0.1V$
RF Input Power (300MHz to 6GHz)	18dBm
RF Input DC Voltage	$\pm 0.1V$
TEMP Monitor Input Current	10mA
Operating Temperature Range (T_C)	-40°C to 105°C
Junction Temperature (T_J)	150°C
Storage Temperature Range	-65°C to 150°C

CAUTION: THIS PART IS SENSITIVE TO ELECTRO-STATIC DISCHARGE (ESD). OBSERVE PROPER ESD PRECAUTIONS WHEN HANDLING THE LTC5577.

BOARD PHOTO

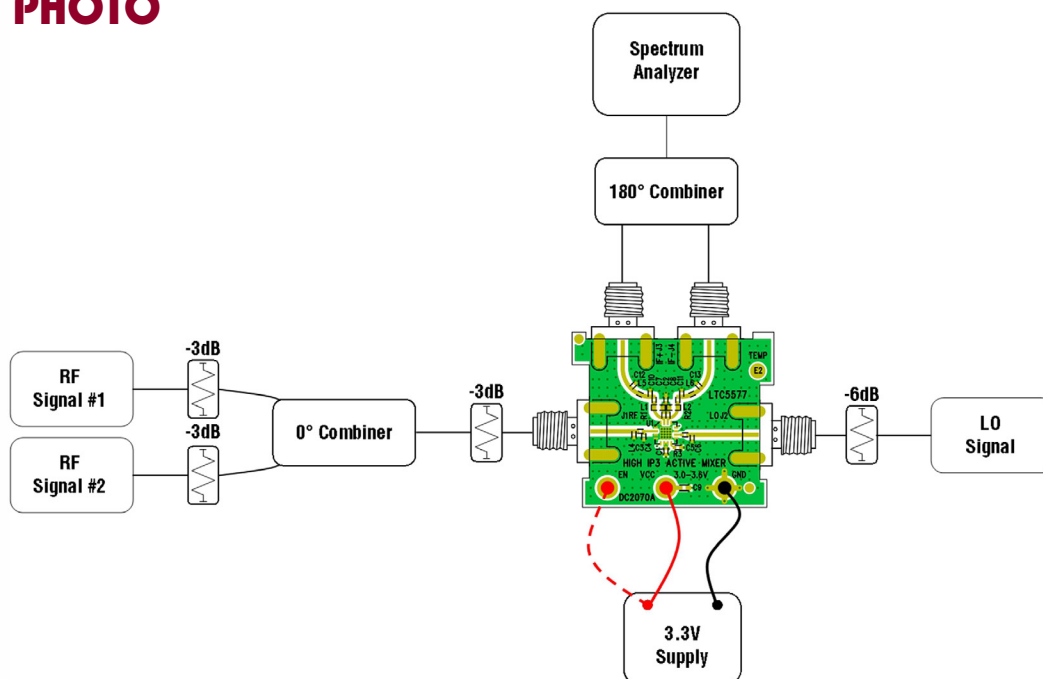

Figure 1. Test Setup for Mixer 2-Tone Measurements

NOTES ON TEST EQUIPMENT AND SETUP

- High performance signal generators with low harmonic outputs should be used for 2-tone measurements. Otherwise, low pass filters at the signal generator outputs should be used to suppress harmonics.
- High quality combiners should be used to present a broadband 50Ω termination on all ports as well as provide good port-to-port isolation. Attenuator pads should be used on the inputs to the combiner and the RF input port of the LTC5577 mixer, as shown in Figure 1. Adding attenuator pads further improves source isolation and helps prevent the signal generators from producing intermodulation products.
- Spectrum analyzers can produce significant internal distortion products if they are overdriven. Generally, spectrum analyzers are designed to operate at their best with about -30dBm to -40dBm at their input. The spectrum analyzer's input attenuation setting should be used to avoid saturating the instrument. Set the spectrum analyzer's input attenuation depending on the spectrum analyzer used.
- Before performing measurements on the DUT, the system performance should be evaluated to ensure that a clean input signal is obtained and that the spectrum analyzer's internal distortion is minimized

PARTS LIST

ITEM	QTY	REFERENCE	PART DESCRIPTION	MANUFACTURER/PART NUMBER
1	4	C1, C2, C7, C8	CAP, 1nF, 10%, 16V, X7R, 0402	MURATA, GRM155R71C102KA01D
2	1	C3	CAP, 8.2pF, ±0.1pF, 50V, NPO, 0402	MURATA, GJM1555C1H8R2CA01D
3	1	C4	CAP, 0.7pF, ±0.1pF, 50V, NPO, 0402	MURATA, GJM1555C1HR70BB01D
4	1	C5	CAP, 3.9pF, ±0.1pF, 50V, NPO, 0402	MURATA, GJM1555C1H3R9BB01D
5	0	R3, L4, L5, L6, C6, C10, C11, C12, C13	COMP, 0402, OPT	0402
6	1	C9	CAP, 1μF, 10%, 10V, X7R, 0603	MURATA, GRM188R61A105KA61D
7	3	E1, E3, E4	TURRET, PAD, 0.094"	MILL-MAX, 2501-2-00-80-00-00-07-0
8	1	E2	TURRET, PAD, 0.061"	MILL-MAX, 2308-2-00-80-00-00-07-0
9	4	J1-J4	CONN, SMA, 50Ω, EDGE-LAUNCH	E.F. JOHNSON, 142-0701-851
10	2	L1, L2	IND, 560nH, 2%, 0603	COILCRAFT, 0603LS-561XGL
11	2	R1, R2	RES, CHIP, 115, 1%, 0402	VISHAY, CRCW0402115RFKED
12	1	U1	IC, LINEAR TECHNOLOGY, LTC5577IUF, QFN16, 4x4	LINEAR TECHNOLOGY, LTC5577IUF

QUICK START PROCEDURE

1. Set the power supply output voltage to 3.3V and the current limit to 250mA. Turn off the power supply output.
2. Connect all test equipment and the power supply as shown in Figure 1.
3. Ramp on the power supply with a minimum ramp time of 1ms.
4. Set the LO signal generator to provide an 1800MHz CW signal at about 0dBm at the DC2070A's LO port.

QUICK START PROCEDURE

5. Set the two RF signal generators to provide one 1949MHz CW signal and one 1951MHz CW signal. The signals should be applied to the 0° combiner. The power applied to the DC2070A's RF input port should be about -3dBm/tone.
6. Perform various measurements (conversion gain, IP3, LO leakage, etc.).
7. To turn off the DC2070A, either turn off the power supply's output, or remove the power leads starting with the EN lead.

SCHEMATIC DIAGRAM

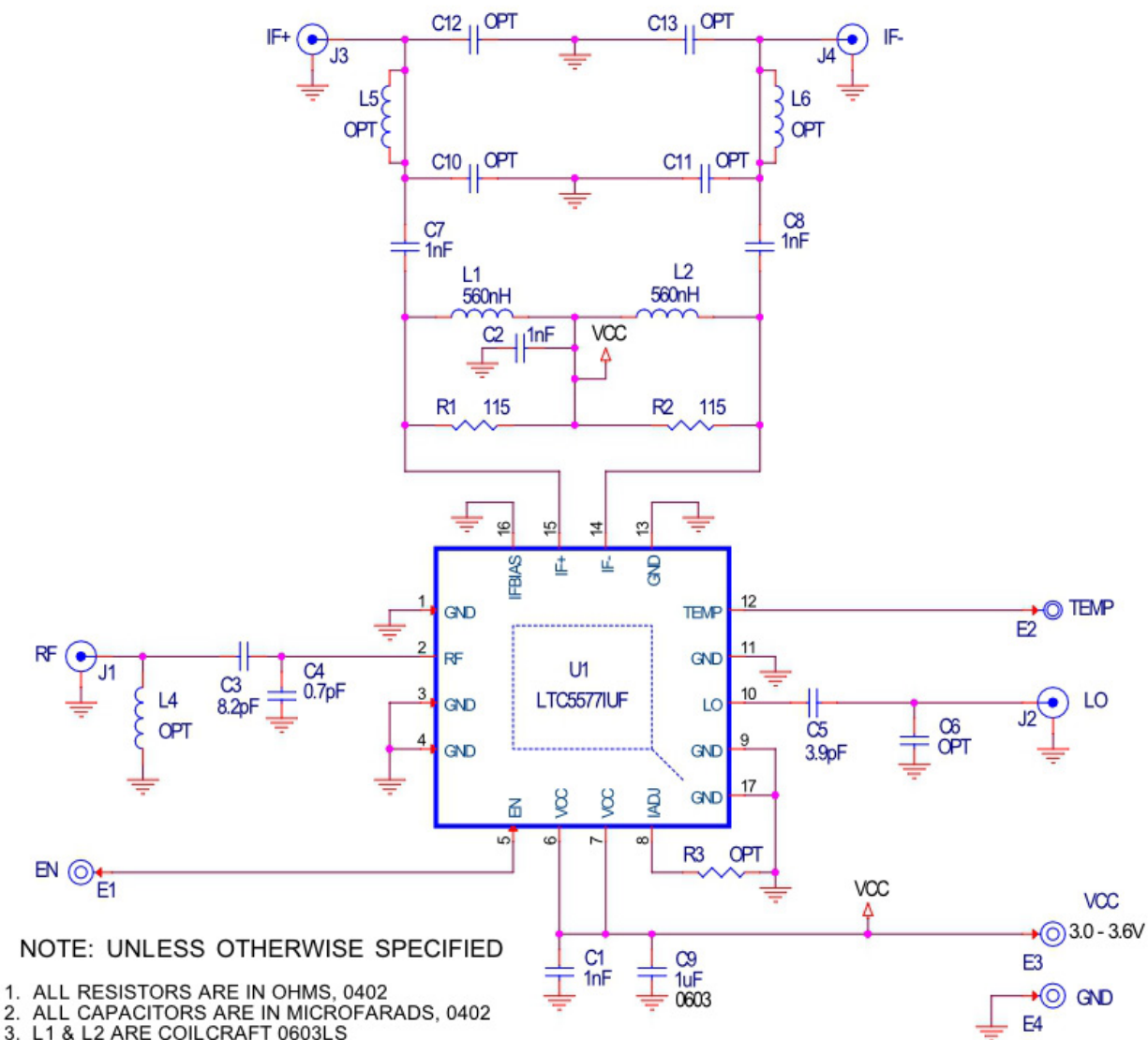

Figure 2. High Signal Level Active Mixer

DEMO MANUAL DC2070A

DEMONSTRATION BOARD IMPORTANT NOTICE

Linear Technology Corporation (LTC) provides the enclosed product(s) under the following **AS IS** conditions:

This demonstration board (DEMO BOARD) kit being sold or provided by Linear Technology is intended for use for **ENGINEERING DEVELOPMENT OR EVALUATION PURPOSES ONLY** and is not provided by LTC for commercial use. As such, the DEMO BOARD herein may not be complete in terms of required design-, marketing-, and/or manufacturing-related protective considerations, including but not limited to product safety measures typically found in finished commercial goods. As a prototype, this product does not fall within the scope of the European Union directive on electromagnetic compatibility and therefore may or may not meet the technical requirements of the directive, or other regulations.

If this evaluation kit does not meet the specifications recited in the DEMO BOARD manual the kit may be returned within 30 days from the date of delivery for a full refund. **THE FOREGOING WARRANTY IS THE EXCLUSIVE WARRANTY MADE BY THE SELLER TO BUYER AND IS IN LIEU OF ALL OTHER WARRANTIES, EXPRESSED, IMPLIED, OR STATUTORY, INCLUDING ANY WARRANTY OF MERCHANTABILITY OR FITNESS FOR ANY PARTICULAR PURPOSE. EXCEPT TO THE EXTENT OF THIS INDEMNITY, NEITHER PARTY SHALL BE LIABLE TO THE OTHER FOR ANY INDIRECT, SPECIAL, INCIDENTAL, OR CONSEQUENTIAL DAMAGES.**

The user assumes all responsibility and liability for proper and safe handling of the goods. Further, the user releases LTC from all claims arising from the handling or use of the goods. Due to the open construction of the product, it is the user's responsibility to take any and all appropriate precautions with regard to electrostatic discharge. Also be aware that the products herein may not be regulatory compliant or agency certified (FCC, UL, CE, etc.).

No License is granted under any patent right or other intellectual property whatsoever. **LTC assumes no liability for applications assistance, customer product design, software performance, or infringement of patents or any other intellectual property rights of any kind.**

LTC currently services a variety of customers for products around the world, and therefore this transaction **is not exclusive**.

Please read the DEMO BOARD manual prior to handling the product. Persons handling this product must have electronics training and observe good laboratory practice standards. **Common sense is encouraged.**

This notice contains important safety information about temperatures and voltages. For further safety concerns, please contact a LTC application engineer.

Mailing Address:

Linear Technology
1630 McCarthy Blvd.
Milpitas, CA 95035

Copyright © 2004, Linear Technology Corporation

X-ON Electronics

Largest Supplier of Electrical and Electronic Components

Click to view similar products for [RF Development Tools](#) category:

Click to view products by [Analog Devices](#) manufacturer:

Other Similar products are found below :

[MAAM-011117](#) [MAAP-015036-DIEEV2](#) [EV1HMC1113LP5](#) [EV1HMC6146BLC5A](#) [EV1HMC637ALP5](#) [EVAL-ADG919EBZ](#) [ADL5363-EVALZ](#) [LMV228SDEVAL](#) [SKYA21001-EVB](#) [SMP1331-085-EVB](#) [EV1HMC618ALP3](#) [EVAL01-HMC1041LC4](#) [MAAL-011111-000SMB](#) [MAAM-009633-001SMB](#) [MASW-000936-001SMB](#) [107712-HMC369LP3](#) [107780-HMC322ALP4](#) [SP000416870](#) [EV1HMC470ALP3](#) [EV1HMC520ALC4](#) [EV1HMC244AG16](#) [MAX2614EVKIT#](#) [124694-HMC742ALP5](#) [SC20ASATEA-8GB-STD](#) [MAX2837EVKIT+](#) [MAX2612EVKIT#](#) [MAX2692EVKIT#](#) [EV1HMC629ALP4E](#) [SKY12343-364LF-EVB](#) [108703-HMC452QS16G](#) [EV1HMC863ALC4](#) [119197-HMC658LP2](#) [EV1HMC647ALP6](#) [ADL5725-EVALZ](#) [106815-HMC441LM1](#) [EV1HMC1018ALP4](#) [UXN14M9PE](#) [MAX2016EVKIT](#) [EV1HMC939ALP4](#) [MAX2410EVKIT](#) [MAX2204EVKIT+](#) [EV1HMC8073LP3D](#) [SIMSA868-DKL](#) [SIMSA868C-DKL](#) [SKY65806-636EK1](#) [SKY68020-11EK1](#) [SKY67159-396EK1](#) [SKY66181-11-EK1](#) [SKY65804-696EK1](#) [SKY13396-397LF-EVB](#)