

LTC4233/LTC4234 10A/20A Guaranteed SOA Hot Swap Controller

DESCRIPTION

Demonstration circuit 2116A features the [LTC4233/LTC[®]4234](#) 10A/20A Guaranteed SOA Hot Swap™ Controllers. The LTC4233 and LTC4234 are ideally suited for compact power distribution control in 2.9V to 15V applications for hot board insertion protection, high side power switching, and electronic circuit breaker functions. They provide a rich set of features to support Hot Swap applications including:

- 2.5% Accurate Undervoltage and Overvoltage Protection
- Overtemperature Protection
- Adjustable Inrush Current Control
- Adjustable, 11% Accurate Current Limit
- Adjustable Output Voltage Ramp Rate

- Configurable for Auto Retry or Latch Off for Overcurrent Faults
- Power Good and Fault Outputs

Available in 38-pin 5mm × 9mm QFN packages, the LTC4234 is showcased on DC2116A-A while the LTC4233 is showcased on DC2116A-B, both configured for a 12V application. By changing a few passive components, 2.9V to 15V applications can easily be evaluated.

Design files for this circuit board are available at <http://www.linear.com/demo/DC2116A>

LT, LT, LTC, LTM, Linear Technology and the Linear logo are registered trademarks and Hot Swap is a trademark of Linear Technology Corporation. All other trademarks are the property of their respective owners.

PERFORMANCE SUMMARY Specifications are at T_A = 25°C

PARAMETER	CONDITIONS	VALUE
Input Supply Voltage Range		2.9V to 15V
Nominal Operating Voltage		12.0V
Overvoltage Lockout	Nominal	15.2V
Undervoltage Lockout (Voltage Falling)	Nominal	9.2V
Undervoltage Lockout (Voltage Rising)	Nominal	9.9V
Output Current Limit	Nominal (LTC4233)	11.2A
	Nominal (LTC4234)	22.5A
Maximum Load Capacitance	Nominal	8200µF
Timer Expiration Period	Nominal	1.2ms or 2.0ms

DEMO MANUAL DC2116A

QUICK START PROCEDURE

Table 1. Power Input and Output Connections

NOMENCLATURE	CONNECTOR	DESCRIPTION
VDD	E13	12V In
GND	E14	12V In Return
VOUT	E6	12V Out
GND	E7	12V Out Return

Table 2. Test Points

NOMENCLATURE	TURRET	DESCRIPTION
INTVCC	E1	INTV _{CC} monitor
TIMER	E2	TIMER pin monitor
PG	E3	PG pin monitor
ISET	E4	I _{SET} pin monitor
IMON	E5	I _{MON} pin monitor
GND	E8	V _{OUT} return monitor
VOUT	E9	V _{OUT} monitor
UV	E10	UV pin monitor
OV	E11	OV pin monitor
VDD	E12	V _{DD} monitor
GND	E15	V _{DD} return monitor
SENSE	E16	SENSE pin monitor
FLT	E17	FLT pin monitor
GATE	E18	GATE pin monitor
GND	E19, E20, E21	Ground

Table 3. LED Indicators

NOMENCLATURE	PART DESIGNATOR	DESCRIPTION
FAULT	D1 (Red)	Indicates Overcurrent Fault
POWER BAD	D2 (Red)	V _{OUT} Not Up to Full Voltage
INPUT POWER	D3 (Green)	Input Voltage Present
OUTPUT POWER	D4 (Green)	Output Voltage Present

Table 4. Jumpers

NOMENCLATURE	PART DESIGNATOR	DESCRIPTION
AUTORETRY	JP1	ON Position for Autoretry
TIMER DURATION	JP2	1.2ms or 2.0ms Timer Duration

DC2116A-A QUICK START PROCEDURE

DC2116A-A is easy to set up to evaluate the performance of the LTC4234. Refer to Figure 1 for proper measurement equipment setup and follow the procedure below.

DC2116A has two user configurable jumper options:

- JP1 AUTORETRY – Set to ON for auto retry or OFF for latch off on over-current faults. (Default position: OFF)
- JP2 TIMER DURATION – Set to 2ms for the internal 2ms timer or 1.2ms determined by C2, C2 may be replaced for other timer durations. (Default position: 1.2ms)

LEDs indicate the state of input power (D2), output power (D4), FAULT (D3) and PG (D1). Load current can be monitored on the IMON turret, which has a value of 0.1V/A determined by RMON (20k.)

Set an adjustable power supply, capable of supplying 30 amps, at 16V. Turn off power and connect the supply to the VDD and GND banana jacks.

Connect a suitable load to the VOUT and GND banana jacks. This load can be an electronic load or power resistors capable of dissipating 300W.

NOTE: Because the LTC4234 incorporates foldback current limiting, the nominal startup current supplied to the load is approximately 5.7A, and may be as low as 4A. This current limit increases linearly until the FB pin exceeds 0.6V ($V_{OUT} > 5.1V$). An electronic constant current load set to ≤ 20 amps will not permit the circuit to turn on unless it is gated on by the PG signal (as would be the case with a DC/DC converter controlled by the PG signal). Resistive loading will not have this problem.

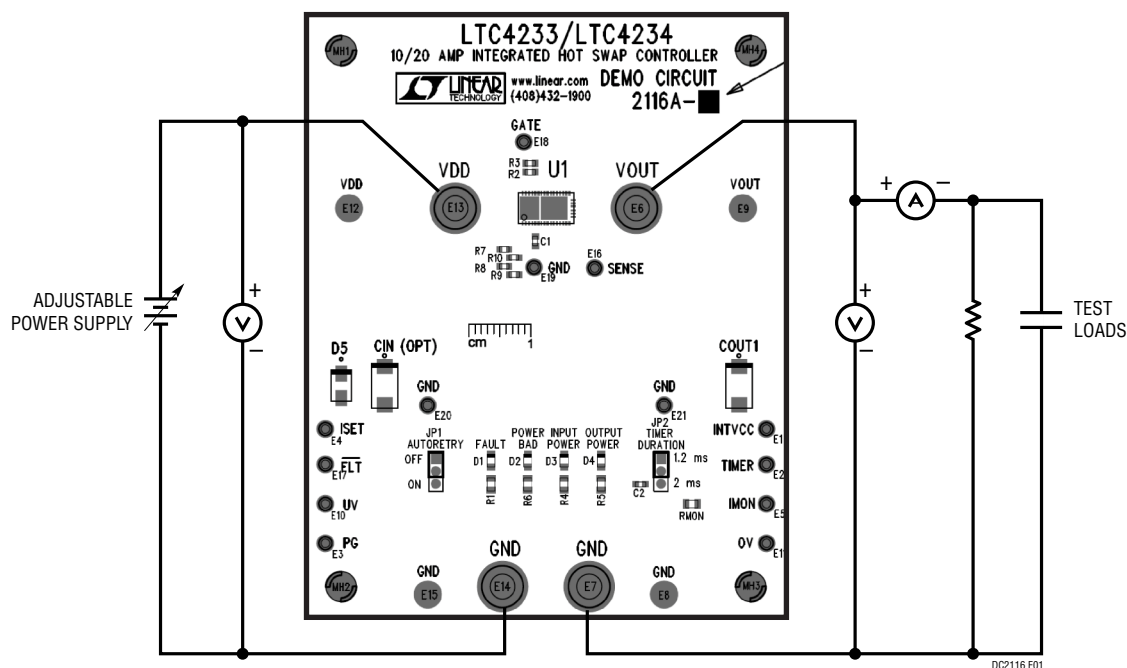

Figure 1. Proper Measurement Equipment Setup

DC2116A-A QUICK START PROCEDURE

Turn on the power supply; verify the input voltage is 12V. Verify the output voltage and the load current; D3 and D4 should both be illuminated (input voltage and output voltage, respectively) and both D1 (FLT) and D2 (PG) should be off. On power-up, observe the slope of V_{OUT} . This should be in the range of 0.15 to 0.55V/ms, corresponding to a ramp-up time of 22ms to 80ms to 12V. With the circuit functioning, additional evaluations can now be performed.

OV/UV/PG thresholds – Set the input supply to zero and ramp the voltage slowly, observing the following events. Above 10.0V, the circuit will be out of UV lockout and the output should ramp up, lighting D4. Above 10.9V the FB pin will be past its threshold, asserting the PG pin high and extinguishing D2. Increasing the supply past 15.2V will engage OV lockout; D4 will extinguish and D2 will light. Note that the voltages indicated in this step are maximums, taking into consideration the tolerances of the resistors and the LTC4234 thresholds.

Current Limit Thresholds – With the input supply set to 12V, load the output with a 0.59Ω power resistor capable of dissipating 300W. Power should remain on, as the current

will be below the 20A minimum current limit threshold. Next, load the output with a 0.48Ω power resistor. Power should be interrupted, as the current will be above the 25A maximum current limit threshold.

Inrush into capacitive load – One of the main functions of a Hot Swap circuit is to provide controlled ramp-up into a capacitive load to avoid disturbing the input power supply. For the following tests, ensure that the AUTORETRY jumper is set to OFF and the TIMER DURATION jumper is set to 2.0ms. To guarantee that current limit is never reached during ramp-up into a capacitor, the current must be less than the minimum current limit threshold of 4A when the gate ramp rate is at its maximum value of 0.6V/ms. (Note that the minimum current limit threshold occurs when the FB pin is at 0V.)

$$C = i/(dV/dt) = 4A/(0.6V/ms) = 6667\mu F$$

Thus the circuit will always power up successfully with a 6000μF capacitor at V_{OUT} , and observation of the TIMER turret post will show that it never begins to ramp.

DC2116A-B QUICK START PROCEDURE

The LTC4233, on the DC2116A-B, should be tested as above with actual values scaled to values shown in the data sheet.

SCHEMATIC DIAGRAM

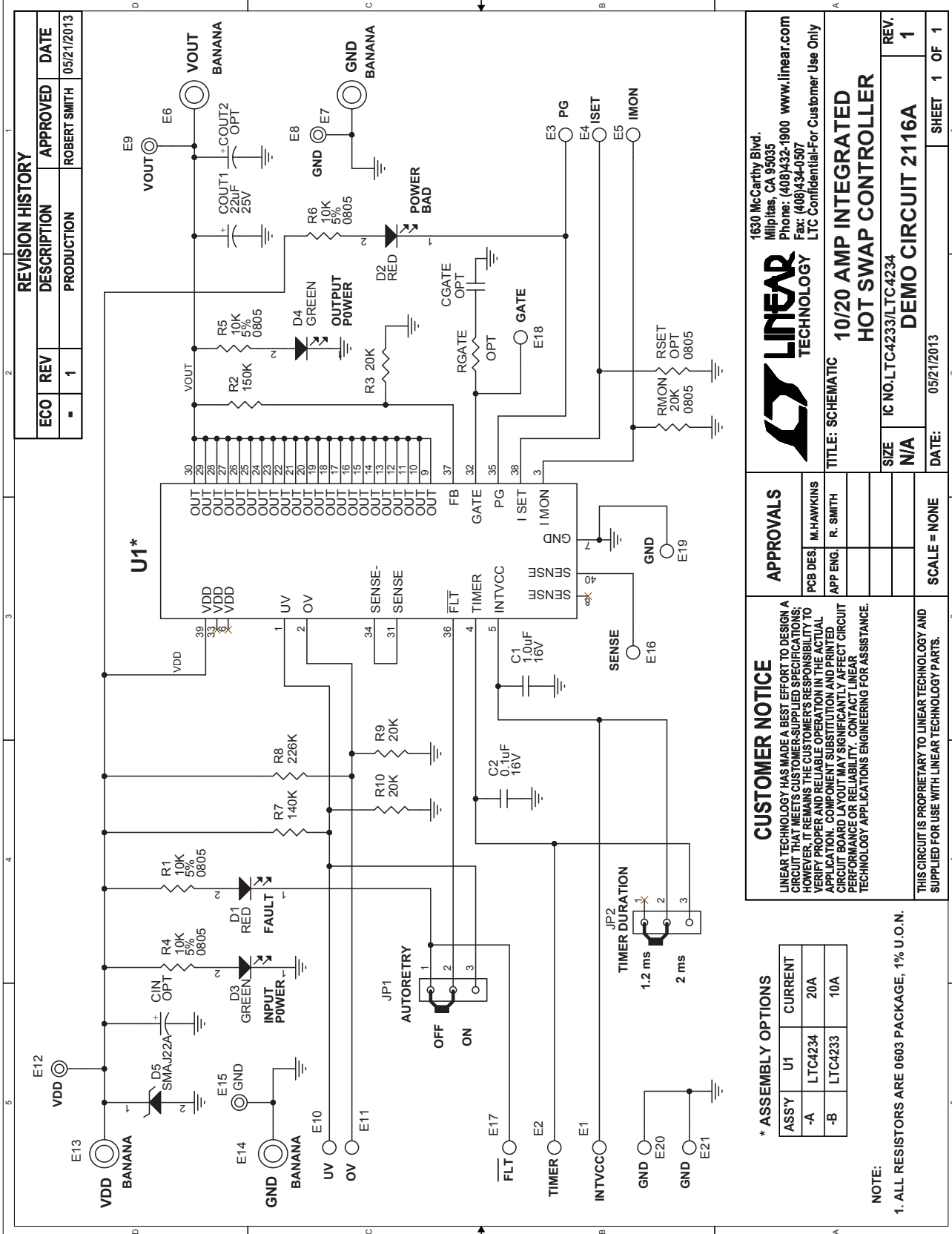

DEMO MANUAL DC2116A

DEMONSTRATION BOARD IMPORTANT NOTICE

Linear Technology Corporation (LTC) provides the enclosed product(s) under the following **AS IS** conditions:

This demonstration board (DEMO BOARD) kit being sold or provided by Linear Technology is intended for use for **ENGINEERING DEVELOPMENT OR EVALUATION PURPOSES ONLY** and is not provided by LTC for commercial use. As such, the DEMO BOARD herein may not be complete in terms of required design-, marketing-, and/or manufacturing-related protective considerations, including but not limited to product safety measures typically found in finished commercial goods. As a prototype, this product does not fall within the scope of the European Union directive on electromagnetic compatibility and therefore may or may not meet the technical requirements of the directive, or other regulations.

If this evaluation kit does not meet the specifications recited in the DEMO BOARD manual the kit may be returned within 30 days from the date of delivery for a full refund. **THE FOREGOING WARRANTY IS THE EXCLUSIVE WARRANTY MADE BY THE SELLER TO BUYER AND IS IN LIEU OF ALL OTHER WARRANTIES, EXPRESSED, IMPLIED, OR STATUTORY, INCLUDING ANY WARRANTY OF MERCHANTABILITY OR FITNESS FOR ANY PARTICULAR PURPOSE. EXCEPT TO THE EXTENT OF THIS INDEMNITY, NEITHER PARTY SHALL BE LIABLE TO THE OTHER FOR ANY INDIRECT, SPECIAL, INCIDENTAL, OR CONSEQUENTIAL DAMAGES.**

The user assumes all responsibility and liability for proper and safe handling of the goods. Further, the user releases LTC from all claims arising from the handling or use of the goods. Due to the open construction of the product, it is the user's responsibility to take any and all appropriate precautions with regard to electrostatic discharge. Also be aware that the products herein may not be regulatory compliant or agency certified (FCC, UL, CE, etc.).

No License is granted under any patent right or other intellectual property whatsoever. **LTC assumes no liability for applications assistance, customer product design, software performance, or infringement of patents or any other intellectual property rights of any kind.**

LTC currently services a variety of customers for products around the world, and therefore this transaction **is not exclusive**.

Please read the DEMO BOARD manual prior to handling the product. Persons handling this product must have electronics training and observe good laboratory practice standards. **Common sense is encouraged.**

This notice contains important safety information about temperatures and voltages. For further safety concerns, please contact a LTC application engineer.

Mailing Address:

Linear Technology
1630 McCarthy Blvd.
Milpitas, CA 95035

Copyright © 2004, Linear Technology Corporation

X-ON Electronics

Largest Supplier of Electrical and Electronic Components

Click to view similar products for [Power Management IC Development Tools](#) category:

Click to view products by [Analog Devices](#) manufacturer:

Other Similar products are found below :

[EVAL-ADM1168LQEBZ](#) [EVB-EP5348UI](#) [MIC23451-AAAYFL EV](#) [MIC5281YMME EV](#) [DA9063-EVAL](#) [ADP122-3.3-EVALZ](#) [ADP130-0.8-EVALZ](#) [ADP130-1.2-EVALZ](#) [ADP130-1.5-EVALZ](#) [ADP130-1.8-EVALZ](#) [ADP1714-3.3-EVALZ](#) [ADP1716-2.5-EVALZ](#) [ADP1740-1.5-EVALZ](#) [ADP1752-1.5-EVALZ](#) [ADP1828LC-EVALZ](#) [ADP1870-0.3-EVALZ](#) [ADP1871-0.6-EVALZ](#) [ADP1873-0.6-EVALZ](#) [ADP1874-0.3-EVALZ](#) [ADP1882-1.0-EVALZ](#) [ADP199CB-EVALZ](#) [ADP2102-1.25-EVALZ](#) [ADP2102-1.875EVALZ](#) [ADP2102-1.8-EVALZ](#) [ADP2102-2-EVALZ](#) [ADP2102-3-EVALZ](#) [ADP2102-4-EVALZ](#) [ADP2106-1.8-EVALZ](#) [ADP2147CB-110EVALZ](#) [AS3606-DB](#) [BQ24010EVM](#) [BQ24075TEVM](#) [BQ24155EVM](#) [BQ24157EVM-697](#) [BQ24160EVM-742](#) [BQ24296MEVM-655](#) [BQ25010EVM](#) [BQ3055EVM](#) [NCV891330PD50GEVB](#) [ISLUSBI2CKIT1Z](#) [LM2744EVAL](#) [LM2854EVAL](#) [LM3658SD-AEV/NOPB](#) [LM3658SDEV/NOPB](#) [LM3691TL-1.8EV/NOPB](#) [LM4510SDEV/NOPB](#) [LM5033SD-EVAL](#) [LP38512TS-1.8EV](#) [EVAL-ADM1186-1MBZ](#) [EVAL-ADM1186-2MBZ](#)