

LTC3895EFE

High Input Voltage Synchronous Buck Converter

DESCRIPTION

Demonstration circuit 2117A is a single output high voltage nonisolated synchronous step-down converter that drives all N-channel MOSFET power stage. It features the LTC3895EFE, a high voltage step-down DC/DC controller housed in a TSSOP-38 package with several pins removed for high voltage spacing.

This DC2117A operates over an input voltage range from 14V to 130V, while the LTC[®]3895 can operate up to 150V. This demo board produces a 12V output voltage with up to a 5A output current, and is configured with a sense resistor for over current protection and has optional DCR sensing.

To prevent high on-chip power dissipation in high input voltage applications, the LTC3895 includes an NDRV pin which drives the gate of an optional external N-channel MOSFET acting as a low dropout linear regulator to supply IC power and is an option on this board.

An internal charge pump allows for 100% duty cycle operation in dropout, a useful feature when powered from a battery during discharge. The LTC3895's powerful 1Ω

N-channel MOSFET gate drivers can be adjusted from 5V to 10V to enable the use of logic- or standard-level MOSFETs to maximize efficiency. The EXT_{V_{CC}} pin permits the LTC3895 to be powered from the output of the switching regulator or other available source, reducing power dissipation and improving efficiency.

A mode selector allows the DC2117A to operate in forced continuous operation, pulse-skipping or low ripple Burst Mode[®] operation during light loads. Additional features include a power good output signal, a PLLIN, PHASEMD and CLKOUT for multiphase operation.

The LTC3895 data sheet gives a complete description of the part, operation and application information and must be read in conjunction with this demo board manual.

Design files for this circuit board are available at <http://www.linear.com/demo/DC2117A>

LT, LT, LTC, LTM, Linear Technology, Burst Mode and the Linear logo are registered trademarks of Linear Technology Corporation. All other trademarks are the property of their respective owners.

PERFORMANCE SUMMARY Specifications are at T_A = 25°C

Table 1.

PARAMETER	CONDITIONS	UNITS
Input Voltage Range	DC Up to 150V _{PK} Transient	14V ~ 130V
Output Voltage V _{OUT}	V _{IN} = 14~130V, I _{OUT} = 0~5A, JP4: FCM	12V ± 2% (11.76V ~ 12.24V)
Maximum Output Current I _{OUT(MAX)}	V _{IN} = 14~130V	5A
Default Operating Frequency (Typical)		150kHz
External Clock Sync Frequency Range		75kHz to 850kHz
Typical Full Load Efficiency (See Figure 4)	V _{IN} = 48V, V _{OUT} = 12V, I _{OUT} = 5A, f _{SW} = 150kHz	94.9%

*Important Note: 60V or higher voltage can result in an electric shock if care is not taken. Also, hot plugging the circuit to a power supply that has more than 40V present at its output can produce a high voltage transient exceeding the absolute maximum input voltage which can damage the DC2117A board.

QUICK START PROCEDURE

Demonstration circuit DC2117A is easy to set up to evaluate the performance of the LTC3895EFE. Refer to Figure 1 for proper measurement equipment setup and follow the procedure below:

NOTE. When measuring the input or output voltage ripple, care must be taken to avoid a long ground lead on the oscilloscope probe. Measure the input or output voltage ripple by touching the probe tip directly across the V_{IN} or V_{OUT} and GND terminals or directly across relevant capacitor. See Figure 2 for proper scope probe technique.

1. Place jumpers in the following positions:

- JP1 ON
- JP4 FCM
- JP5 ON
- JP8 OFF

2. With power off, connect the input power supply to V_{IN} and GND.
3. Turn on the power at the input.

NOTE. Make sure that the input voltage is higher than 14V and does not exceed 130V.

4. Check the output voltage. The output voltage should be between 11.76V and 12.24V.

Once the proper output voltage is established, adjust the load within the operating range and observe the output voltage regulation, output voltage ripple, efficiency and other parameters.

NOTE. If there is no output, temporarily disconnect the load to make sure that the load is not set too high.

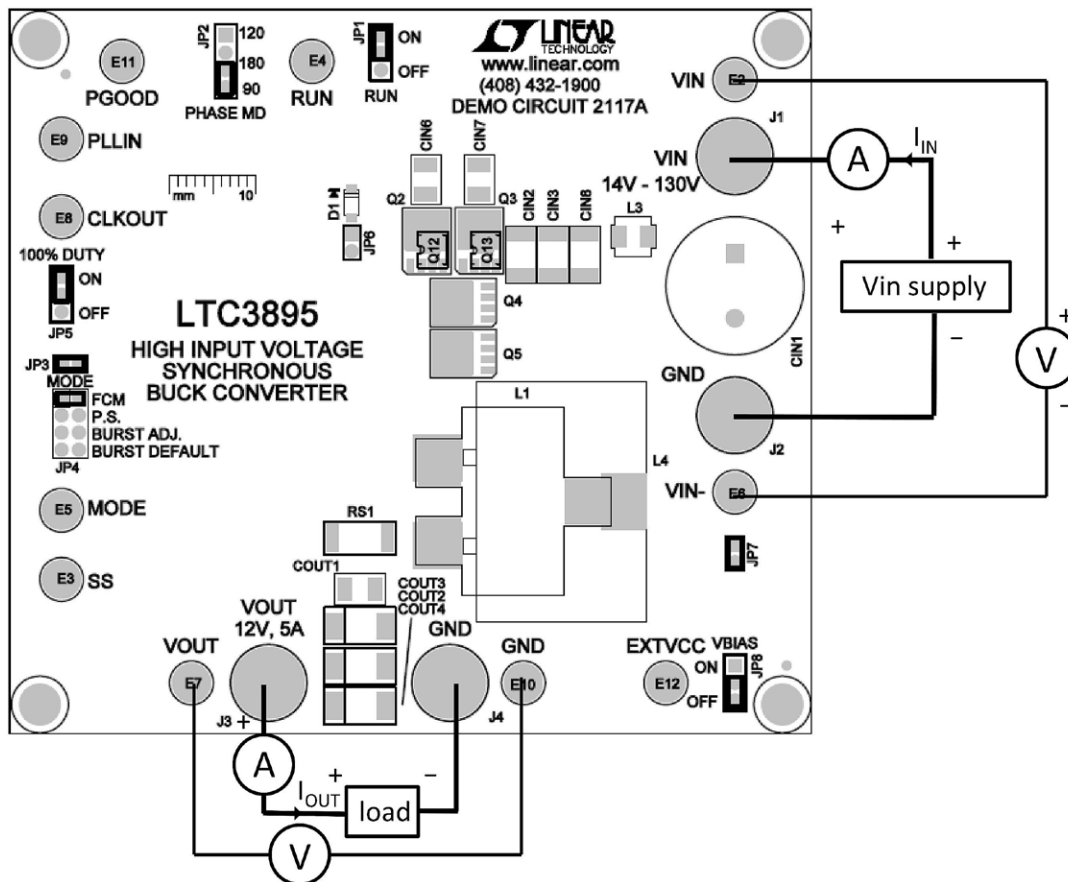

Figure 1. Proper Measurement Equipment Setup

QUICK START PROCEDURE

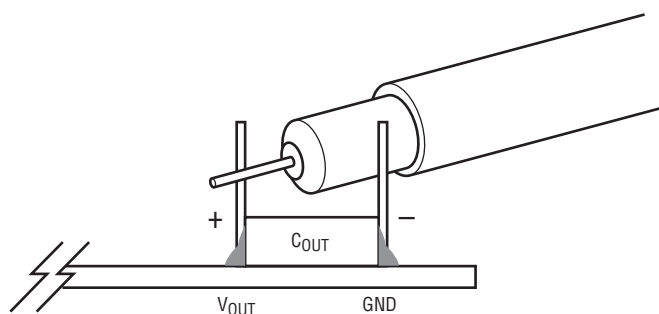

Figure 2. Measuring Input or Output Ripple Across Terminals or Directly Across Ceramic Capacitor

FREQUENCY SYNCHRONIZATION AND MODE SELECTION

Demonstration circuit 2117A's mode selector allows the converter to run in forced continuous operation, pulse-skipping operation, Burst Mode operation or Burst Mode operation with adjustable clamp level by changing the position of JP4. To synchronize the DC2117A to an external

clock, apply the sync signal to the PLLIN turret. Depending upon the JP4 setting, the DC2117A will operate in different modes. See Table 2 for the detailed description.

Table 2. Mode Selection and Synchronized Operation Options

CONFIGURATION	JP4	MODE WITH SYNC SIGNAL SUPPLIED TO PLLIN
Forced Continuous Operation	FCM	FCM
Pulse-Skipping Operation	PS	PS
Burst Mode Operation with Adjustable Clamp Level	BURST ADJ	FCM
Burst Mode Operation with Default Clamp	BURST DEFAULT	FCM

100% DUTY

Demonstration circuit 2117A features 100% duty cycle operation in dropout. Set the JP5 to ON position to activate this feature. Set JP5 to OFF position disables the internal

charge pump and enables boost refresh, allowing for 99% duty cycle operation in dropout.

OPTIONAL INDUCTOR DCR CURRENT SENSING

Demonstration circuit 2117A provides an optional circuit for inductor DCR current sensing. Inductor DCR current sensing uses the DCR of the inductor to sense the inductor current instead of discrete sense resistors. The advantages of DCR sensing are lower cost, reduced board space and higher efficiency, but the disadvantage is a less accurate

current limit. If DCR sensing is used, be sure to select an inductor current with a sufficiently high saturation current or use an iron powder type material.

Refer to Table 3 for optional inductor DCR current sensing setup and to the data sheet for more details.

Table 3. Optional Inductor DCR Current Sensing

CONFIGURATION	RS1	R24	R28	C16	R37	R38	R39	R40
Current Sense Resistor (Default)	Ref Sch	Ref Sch	Ref Sch	OPEN	OPEN	OPEN	OPEN	OPEN
Inductor DCR Current Sensing	0Ω Copper	OPEN	OPEN	Calculated Value from Data Sheet			0Ω	0Ω

LOW QUIESCENT CURRENT APPLICATIONS AND MEASUREMENT

The typical quiescent current (I_Q) of the LTC3895 controller is 40μA in sleep mode as specified in the LTC3895 data sheet. However, the input current of the DC2117A board can be higher than this value because of additional circuit

outside of the IC. To reduce the total input current, large value FB divider resistors should be used. In addition, some jumpers and resistors should be configured accordingly. Refer to Table 4 for the low input quiescent current setup.

Table 4. Low Input Quiescent Current Configuration

Reference Designator	R1	R2	R23	JP3	JP4	JP5	JP8
Function	OVLO		PGOOD	INTV _{CC} Jumper	MODE Selector	100% DUTY	BIAS Supply
Stuffing Option	OPEN	0Ω	OPEN	OPEN	BURST ADJ or BURST DEFAULT	OFF	OFF

EXTV_{CC} BIAS SUPPLY

By default, the DC2117A EXTV_{CC} turret is tied to the 12V V_{OUT} to save IC power loss.

To power the EXTV_{CC} from onboard bias supply:

1. Leave the JP7 OPEN. This step disconnects the EXTV_{CC} from V_{OUT}.
2. Keep the JP8 at the ON position. The onboard BIAS supply output voltage is 12V.

Alternatively, EXTV_{CC} can also be powered by an external power supply:

1. Leave the JP7 OPEN.
2. Keep the JP8 at the OFF position.
3. Apply a DC voltage (<14V) between the EXTV_{CC} and GND turret, after the input voltage is established. Ensure that $EXTV_{CC} \leq V_{IN}$.

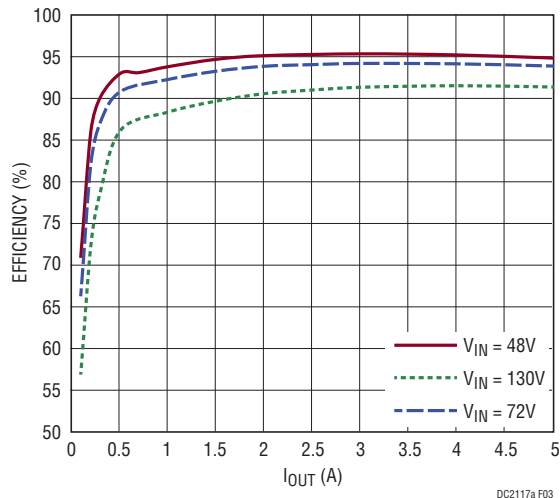

Figure 3. DC2117A V_{OUT} Typical Efficiency vs Load Current

EXTV_{CC} BIAS SUPPLY

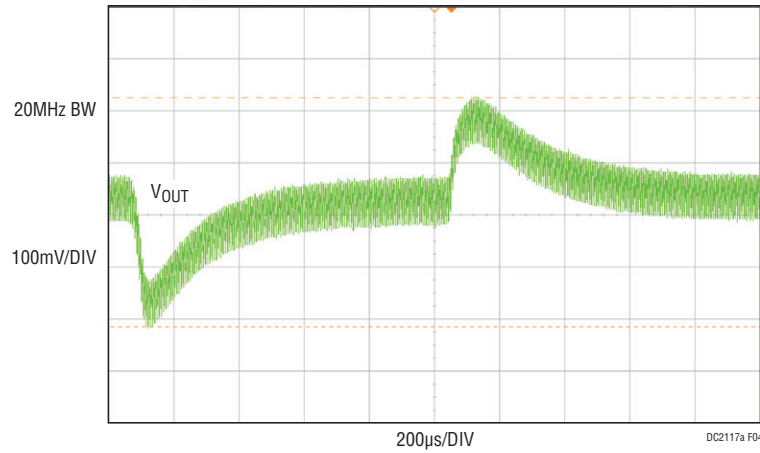

Figure 4. DC2117A V_{OUT} 1.25A ~ 2.5A Load Transient at $V_{IN} = 48V$

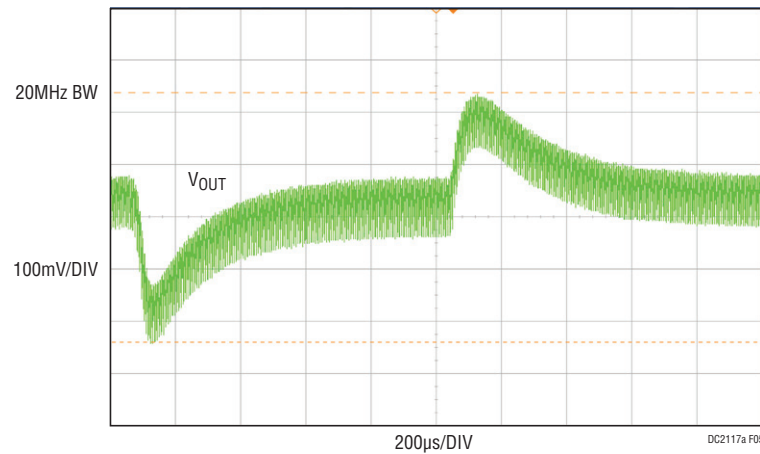

Figure 5. DC2117A V_{OUT} 1.25A ~ 2.5A Load Transient at $V_{IN} = 130V$

PARTS LIST

ITEM	QTY	REFERENCE	PART DESCRIPTION	MANUFACTURER/PART NUMBER
Required Circuit Components				
1	1	CIN1	CAP, 100µF 20% 200V ELEC	NIC NRB-XS101M200V16x20TBF
2	5	CIN2, CIN3, CIN4, CIN5, C14	CAP, 1812 0.47µF 10% 200V X7R	MURATA GRM43DR72E474KW01L
3	2	CIN6, CIN7	CAP, 1210 0.1µF 10% 200V X7R	MURATA GRM32DR72D104KW01L
4	1	COUT1	CAP, 1210 22µF 10% 16V X7R	TDK C3225X7R1C226K
5	2	COUT2, COUT3	CAP, 7343 150µF 20% 16V	AVX TPSD157M016R0125
6	3	C2, C4, C13	CAP, 0603 0.1µF 10% 25V X7R	TDK C1608X7R1E104K
7	1	C3	CAP, 0603 1nF 10% 50V X7R	AVX 06035C102KAT2A
8	1	C6	CAP, 0603 4700pF 10% 50V X7R	AVX 06035C472KAT2A
9	1	C7	CAP, 0603 1µF 20% 16V X7R	TDK C1608X7R1C105M
10	1	C9	CAP, 0603 10pF 10% 50V X7R	AVX 06035C100KAT2A
11	1	C10	CAP, 0603 100pF 5% 50V NPO	AVX 06035A101JAT2A
12	1	C11	CAP, 1206 0.033µF 20% 200V	VISHAY VJ1206Y333MXCAC
13	1	C12	CAP, 0603 4.7µF 20% 16V X5R	TDK C1608X5R1C475M080AC
14	1	C15	CAP, 1210 4.7µF 20% 16V X7R	AVX 1210YC475KAT2A
15	1	L1	IND, 33µH 15%	WURTH ELEKTRONIK 7443633300
16	1	L2	IND, 470µH	COILCRAFT MSS1048T-474KLB
17	1	L3	IND, 1.0µH	VISHAY IHLP-1616BZER1R0M11
18	3	Q2, Q3, Q4	XSTR, N-CHANNEL DMOS FET	INFINEON BSC520N15NS3G
19	1	RS1	RES, 2512 0.006Ω 5% 1/4W	VISHAY WSL25126L000FEA18
20	1	R1	RES, 0603 191k 1% 1/10W	VISHAY CRCW0603191KFKEA
21	1	R2	RES, 0603 1.74k 1% 1/10W	VISHAY CRCW06031K74FKEA
22	8	R8, R10, R22, R24, R27, R28, R29, R35	RES, 0603 0Ω JUMPER	VISHAY CRCW06030000Z0EA
23	1	R9	RES, 0603 10M 5% 1/10W	VISHAY CRCW060310M0JNEA
24	1	R12	RES, 0603 2.2Ω 5% 1/10W	VISHAY CRCW06032R20JNEA
25	1	R13	RES, 0603 10k 1% 1/10W	VISHAY CRCW060310K0FKEA
26	1	R14	RES, 0603 10k 5% 1/10W	VISHAY CRCW060310K0JNEA
27	1	R15	RES, 0603 140k 1% 1/10W	VISHAY CRCW0603140KFKEA
28	3	R16, R17, R23	RES, 0603 100k 5% 1/10W	VISHAY CRCW0603100KJNEA
29	1	R18	RES, 0603 49.9k 1% 0.1W	VISHAY CRCW060349K9FKEA
30	1	R25	RES, 0603 30.1k 1% 1/10W	VISHAY CRCW060330K1FKEA
31	1	R26	RES, 0603 80.6k 1% 1/10W	VISHAY CRCW060380K6FKEA
32	2	R30, R36	RES, 0603 10Ω 1% 1/10W	VISHAY CRCW060310R0FKEA
33	1	R31	RES, 0603 2M 1% 1/10W	VISHAY CRCW06032M00FKEA
34	1	R32	RES, 0603 267k 1% 1/10W	VISHAY CRCW0603267KFKEA
35	1	R34	RES, 0603 196k 1% 1/10W	VISHAY CRCW0603196KFKEA
36	1	U1	IC, SYNCHRONOUS BUCK CONVERTER	LINEAR TECH. LTC3895EFE
37	1	U2	IC, SYNCHRONOUS STEP-DOWN REGULATOR	LINEAR TECH LTC3639EMSE

DEMO MANUAL DC2117A

PARTS LIST

ITEM	QTY	REFERENCE	PART DESCRIPTION	MANUFACTURER/PART NUMBER
Additional Demo Board Circuit Components				
1	0	CIN8	CAP, 1812 OPTION	OPTION
2	0	COUT4	CAP, 7343 OPTION	OPTION
3	0	C1, C5, C8, C16	CAP, 0603 OPTION	OPTION
4	0	D1, D2	DIODE, OPTION	OPTION
5	0	L1 – ALTERNATE	IND, 33 μ H 15%	WURTH ELEKTRONIK 7443643300
6	0	L4	IND, 22 μ H OPTION	COILCRAFT SER2915H-223KL OPTION
7	0	Q1	XSTR, POWER	OPTION
8	0	Q5	XSTR, NMOS OPTION	OPTION
9	0	Q6, Q7	XSTR, OPTIMOS POWER -TRANSISTOR OPTION	INFINEON IPD320N20N3 G OPTION
10	0	Q12, Q13	XSTR, OPTION	OPTION
11	0	R3, R4, R5, R6, R7, R11, R19, R20, R21, R37, R38, R39, R40	RES, 0603 OPTION	OPTION
12	0	R33	RES, 1206 OPTION	OPTION
Hardware				
1	11	E2, E3, E4, E5, E6, E7, E8, E9, E10, E11, E12	TURRET	MILL-MAX 2501-2-00-80-00-00-07-0
2	3	JP1, JP5, JP8	HEADER, 3-PIN, 2mm	SULLINS NRPN031PAEN-RC
3	1	JP2	HEADER, 4-PIN 2mm	SULLINS NRPN041PAEN-RC
4	3	JP3, JP6, JP7	HEADER, 2-PIN, 2mm	SULLINS NRPN021PAEN-RC
5	1	JP4	HEADER, DOUBLE ROW 2mm x 4 2mm	SULLINS NRPN042PAEN-RC
6	4	J1, J2, J3, J4	JACK, BANANA	KEYSTONE 575-4
7	8	XJP1, XJP2, XJP3, XJP4, XJP5	SHUNT, 2mm	SAMTEC 2SN-BK-G
8	4	XJP6, XJP7, XJP8, XJP6, XJP7, XJP8	STANDOFF, SNAP ON	KEYSTONE_8833

SCHEMATIC DIAGRAM

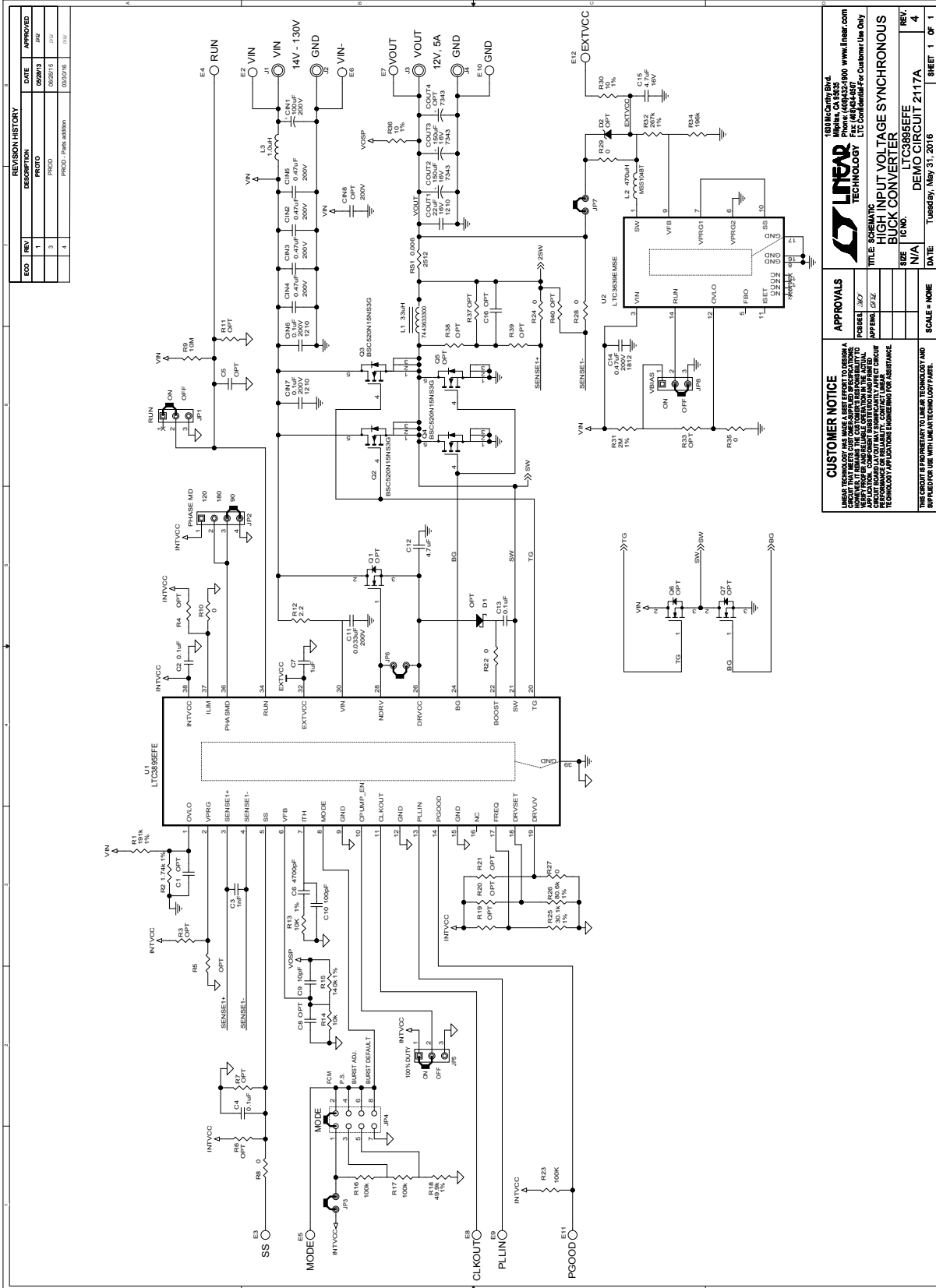

REVISION HISTORY

ECO	REV	DESCRIPTION	DATE	APPROVED
	1	INITIAL	06/24/13	JFA
	2	REVISED	06/24/13	JFA
	3	REVISED	06/24/13	JFA
	4	REVISED	06/24/13	JFA

CUSTOMER NOTICE
 LINEAR TECHNOLOGY HAS MADE A BEST EFFORT TO DESIGN A SCHEMATIC THAT REPRESENTS THE CUSTOMER'S REQUIREMENTS TO THE MAXIMUM EXTENT POSSIBLE. HOWEVER, IT REMAINS THE CUSTOMER'S RESPONSIBILITY TO VERIFY THE SCHEMATIC REPRESENTS THE CUSTOMER'S REQUIREMENTS AND TO VERIFY THE SCHEMATIC REPRESENTS THE CUSTOMER'S REQUIREMENTS TO THE MAXIMUM EXTENT POSSIBLE. LINEAR TECHNOLOGY APPLICATORS ENGINEERING FOR ASSISTANCE.

APPROVALS

DESIGNER	DATE	DESIGNED BY	DATE

LINEAR TECHNOLOGY
 1680 McCarthy Blvd.
 Fremont, CA 94538-1699
 Phone: (925) 462-4600
 Fax: (925) 462-4607
 www.linear.com
 LTC Customer Service Center Use Only

TITLE SCHEMATIC
HIGH INPUT VOLTAGE SYNCHRONOUS BUCK CONVERTER

LT3895EFE

SIZE: N/A
 SCALE: NONE
 DATE: Tuesday, May 31, 2016
 SHEET 1 OF 1



Information furnished by Linear Technology Corporation is believed to be accurate and reliable. However, no responsibility is assumed for its use. Linear Technology Corporation makes no representation that the interconnection of its circuits as described herein will not infringe on existing patent rights.

DEMO MANUAL DC2117A

DEMONSTRATION BOARD IMPORTANT NOTICE

Linear Technology Corporation (LTC) provides the enclosed product(s) under the following **AS IS** conditions:

This demonstration board (DEMO BOARD) kit being sold or provided by Linear Technology is intended for use for **ENGINEERING DEVELOPMENT OR EVALUATION PURPOSES ONLY** and is not provided by LTC for commercial use. As such, the DEMO BOARD herein may not be complete in terms of required design-, marketing-, and/or manufacturing-related protective considerations, including but not limited to product safety measures typically found in finished commercial goods. As a prototype, this product does not fall within the scope of the European Union directive on electromagnetic compatibility and therefore may or may not meet the technical requirements of the directive, or other regulations.

If this evaluation kit does not meet the specifications recited in the DEMO BOARD manual the kit may be returned within 30 days from the date of delivery for a full refund. **THE FOREGOING WARRANTY IS THE EXCLUSIVE WARRANTY MADE BY THE SELLER TO BUYER AND IS IN LIEU OF ALL OTHER WARRANTIES, EXPRESSED, IMPLIED, OR STATUTORY, INCLUDING ANY WARRANTY OF MERCHANTABILITY OR FITNESS FOR ANY PARTICULAR PURPOSE. EXCEPT TO THE EXTENT OF THIS INDEMNITY, NEITHER PARTY SHALL BE LIABLE TO THE OTHER FOR ANY INDIRECT, SPECIAL, INCIDENTAL, OR CONSEQUENTIAL DAMAGES.**

The user assumes all responsibility and liability for proper and safe handling of the goods. Further, the user releases LTC from all claims arising from the handling or use of the goods. Due to the open construction of the product, it is the user's responsibility to take any and all appropriate precautions with regard to electrostatic discharge. Also be aware that the products herein may not be regulatory compliant or agency certified (FCC, UL, CE, etc.).

No License is granted under any patent right or other intellectual property whatsoever. **LTC assumes no liability for applications assistance, customer product design, software performance, or infringement of patents or any other intellectual property rights of any kind.**

LTC currently services a variety of customers for products around the world, and therefore this transaction **is not exclusive**.

Please read the DEMO BOARD manual prior to handling the product. Persons handling this product must have electronics training and observe good laboratory practice standards. **Common sense is encouraged.**

This notice contains important safety information about temperatures and voltages. For further safety concerns, please contact a LTC application engineer.

Mailing Address:

Linear Technology
1630 McCarthy Blvd.
Milpitas, CA 95035

Copyright © 2004, Linear Technology Corporation

X-ON Electronics

Largest Supplier of Electrical and Electronic Components

Click to view similar products for [Power Management IC Development Tools](#) category:

Click to view products by [Analog Devices](#) manufacturer:

Other Similar products are found below :

[EVAL-ADM1168LQEBZ](#) [EVB-EP5348UI](#) [MIC23451-AAAYFL EV](#) [MIC5281YMME EV](#) [DA9063-EVAL](#) [ADP122-3.3-EVALZ](#) [ADP130-0.8-EVALZ](#) [ADP130-1.2-EVALZ](#) [ADP130-1.5-EVALZ](#) [ADP130-1.8-EVALZ](#) [ADP1714-3.3-EVALZ](#) [ADP1716-2.5-EVALZ](#) [ADP1740-1.5-EVALZ](#) [ADP1752-1.5-EVALZ](#) [ADP1828LC-EVALZ](#) [ADP1870-0.3-EVALZ](#) [ADP1871-0.6-EVALZ](#) [ADP1873-0.6-EVALZ](#) [ADP1874-0.3-EVALZ](#) [ADP1882-1.0-EVALZ](#) [ADP199CB-EVALZ](#) [ADP2102-1.25-EVALZ](#) [ADP2102-1.875EVALZ](#) [ADP2102-1.8-EVALZ](#) [ADP2102-2-EVALZ](#) [ADP2102-3-EVALZ](#) [ADP2102-4-EVALZ](#) [ADP2106-1.8-EVALZ](#) [ADP2147CB-110EVALZ](#) [AS3606-DB](#) [BQ24010EVM](#) [BQ24075TEVM](#) [BQ24155EVM](#) [BQ24157EVM-697](#) [BQ24160EVM-742](#) [BQ24296MEVM-655](#) [BQ25010EVM](#) [BQ3055EVM](#) [NCV891330PD50GEVB](#) [ISLUSBI2CKIT1Z](#) [LM2744EVAL](#) [LM2854EVAL](#) [LM3658SD-AEV/NOPB](#) [LM3658SDEV/NOPB](#) [LM3691TL-1.8EV/NOPB](#) [LM4510SDEV/NOPB](#) [LM5033SD-EVAL](#) [LP38512TS-1.8EV](#) [EVAL-ADM1186-1MBZ](#) [EVAL-ADM1186-2MBZ](#)