

DESCRIPTION

Demonstration circuit 2130A, when used with a spectrum analyzer, makes conducted EMI measurement of DC/DC converters convenient over a wide range of frequencies and EMI levels – beyond the highest automotive conducted EMI test frequencies and below the EMI levels generated by power electronics with the latest chip and printed circuit board designs for low noise. Measurements above 108MHz , which is the high-end of the CISPR 25 conducted EMI frequency range, are beneficial to predict radiated measurement results from open area test sites (OATS) or anechoic chambers (ALSE = Absorber-lined shielded enclosure) without the expense and effort associated with those testing methods.

-10dB and $+30\text{dB}$ LISNs

To provide its broad frequency and signal level coverage, DC2130A includes two completely separate Line Impedance Stabilization Networks (LISNs), or artificial networks (ANs), that are divided by an unbroken score down the center of the circuit board. The two LISNs can be separated at the score but care is required so the ceramic capacitors are not damaged by mechanical stress during separation.

WARNING: THE SCORED EDGES ARE SHARP AFTER SEPARATION. DE-BUR THE EDGES BEFORE HANDLING.

Each LISN has a 50Ω high-frequency (HF) output and connects to the spectrum analyzer using a bulkhead-type SMA connector that can fasten to the wall of an enclosure if desired.

One LISN is labeled -10dB because the conducted RF noise of the device-under-test (DUT) measured by that LISN is attenuated by -10dB . The other LISN that comes with DC2130A has a gain of $+30\text{dB}$. DC2130A ships with the $+30\text{dB}$ LISN configured as a $+30\text{dB}$ standalone gain stage, but can be easily configured to a $+30\text{dB}$ LISN instead. The capacitor on the C21 pads must be relocated (re-soldered) to the C17 pads in order to configure the

$+30\text{dB}$ gain stage as a $+30\text{dB}$ LISN. A 50Ω HF input is provided for connection to the standalone gain stage.

Inductors and Current Rating

Each of DC2130A's LISNs has $5.5\mu\text{H}$ of inductance which form a second order filter with a capacitor at the input supply side of the LISN which simulates the typical harness impedance seen by the DUT and isolates the DUT measurement from radio frequencies generated by the input supply. The 10A inductor current rating imposes a 10A limit on the current DC2130A can pass from the input supply to the DUT.

Frequency Range and Gain Correction

The -10dB LISN is suitable for measurements up to 800MHz if gain correction is used for frequencies above 600MHz . The output of the -10dB LISN rolls off at low frequencies similarly to other LISNs so gain correction is normally not required at low frequencies. The $+30\text{dB}$ LISN and $+30\text{dB}$ standalone gain stage are suitable for measurements from 10MHz to 2.5GHz if gain corrections are used from 10MHz to 47MHz and from 2GHz to 2.5GHz .

Spectrum Analyzer Setup

When using the -10dB LISN the spectrum analyzer must be programmed for an external gain (attenuation) of -10dB . When using the $+30\text{dB}$ LISN or standalone gain stage the spectrum analyzer must be programmed for an external gain of $+30\text{dB}$.

Input Supply Voltage Limit

The rating for the LISN input supply voltage is 60VDC at VIN+ with respect to VIN- . There are polarized capacitors at the input supply terminals, so AC voltages and voltages of the opposite polarity are not permitted.

LT, LT, LTC, LTM, Linear Technology and the Linear logo are registered trademarks of Linear Technology Corporation. All other trademarks are the property of their respective owners.

DESCRIPTION

Protection for the Spectrum Analyzer and LISN Amplifier Inputs

The LISNs interface the noise at the DUT terminals to the spectrum analyzer through a high-pass filter. The high-pass filter blocks all DC voltage before the signal gets to the spectrum analyzer. The -10dB LISN interface circuit contains limiting diodes to protect the sensitive input stage of the following receiver or spectrum analyzer. The limiting diodes do not create additional distortion due to excessive RF signals if there is no spectral content above $80\text{dB}\mu\text{V}$. At that point the distortion from the diodes should be below the 50Ω noise floor at room temperature.

The $+30\text{dB}$ gain stage consists of two LTC6431 amplifiers in series, and similar to the limiting diodes for the -10dB LISN, the measurement output of the $+30\text{dB}$ LISN is limited to around 2V peak-to-peak and 20dBm by the characteristics of the LTC6431 amplifier. The input to the $+30\text{dB}$ gain stage is protected by a 1nF 560nH high pass filter.

LISN Amplifier Power

Terminals are provided for connection to an external supply to provide power to the $+30\text{dB}$ gain stage amplifiers. The voltage at the amplifier power terminals is subsequently regulated to 5V by an LT1965 LDO. The LDO prevents the external supply from damaging the LTC6431 amplifiers by overvoltage. The LTC6431 gain-stage amplifiers result in an approximately 200mA input current from the external supply. A green high-brightness LED indicates that power is being consumed from the external supply. The user can provide 5.4V to 20V to the DC2130A ampli-

fier power terminals, although supply voltages above 6V only create additional heat. 20V is actually a challenge for the LT1965 even though it is in a low thermal resistance DD-PAK package, and 14V is a more realistic limit for the external supply voltage.

DC lab supplies or DC wall adaptors used as external power must have sufficiently low AC ripple and should not introduce any AM around a test signal that is known to have low phase noise, as seen by the spectrum analyzer. A battery used for external power will have the best results for this type of test.

LISN Power Connections

Power connections to the LISNs are made using 10A banana jack connectors. Center to center distance on the banana jacks are 19mm so standard spacing connectors may be used.

Additional Mechanical and Other

Four 0.187 inch diameter grounded mounting holes that accept 3mm screws are provided for both the -10dB and $+30\text{dB}$ LISNs. The LISNs may be mounted with either side of the assembly facing up, and there are silkscreen legends on both pcb sides to clearly indicate VIN and DUT polarity so incorrect connections can be avoided. There are placeholders for high frequency damping resistors in parallel with the LISN inductors.

Design files for this circuit board are available at <http://www.linear.com/demo/DC2130A>

PERFORMANCE SUMMARY Specifications are at $T_A = 25^\circ\text{C}$

PARAMETER	CONDITIONS	MIN	TYP	MAX
Maximum Input Voltage, V_{VIN^+}, V_{VIN^-}		60V		
Maximum DUT Current, I_{DUT}		10A		
LISN Inductance			5.5 μ H	
-10dB LISN				
Highest Frequency for -10dB Gain	Gain Decreases to 3dB Below the Pass Band Gain of -10dB		600MHz	
Highest Frequency for Usable Gain	With Gain Correction		800MHz	
+30dB LISN and +30dB Amplifier				
Lowest and Highest Frequencies for 30dB Gain	Gain is within -3dB of the Pass Band Gain of 30dB		46MHz to 2GHz	
Lowest and Highest Frequencies for Usable Gain	With Gain Correction		10MHz to 2.5GHz	
Noise Figure	500MHz		3.6dB	
Minimum External Supply Voltage, V_{EXT}				5.4V
Maximum External Supply Voltage, V_{EXT}		20V		
External Supply Input Current			200mA	

DEMO MANUAL DC2130A

BOARD PHOTO

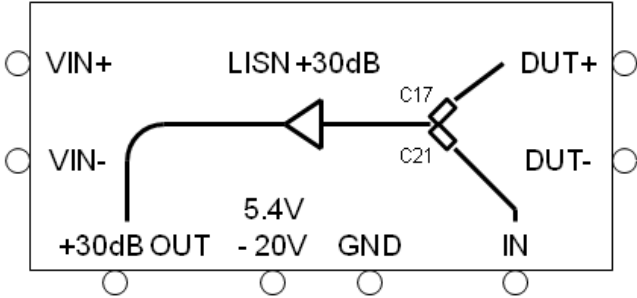
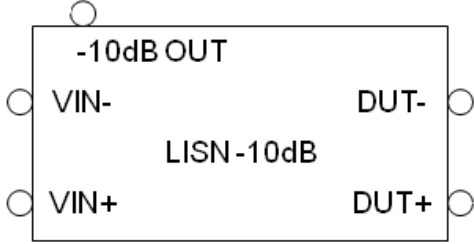
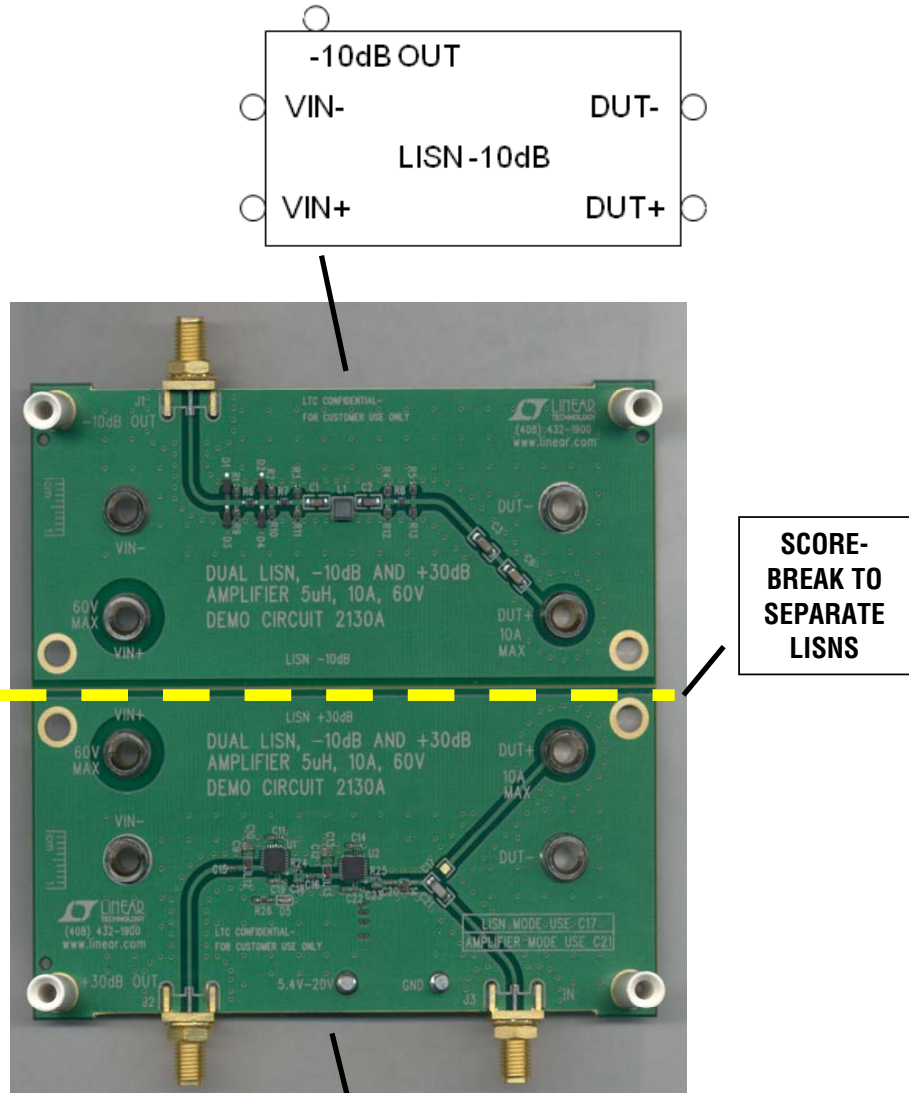

**AMPLIFIER
POWER
TERMINALS**

Top View

BOARD PHOTO

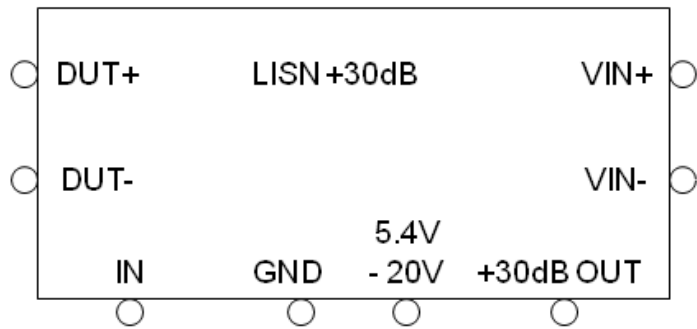
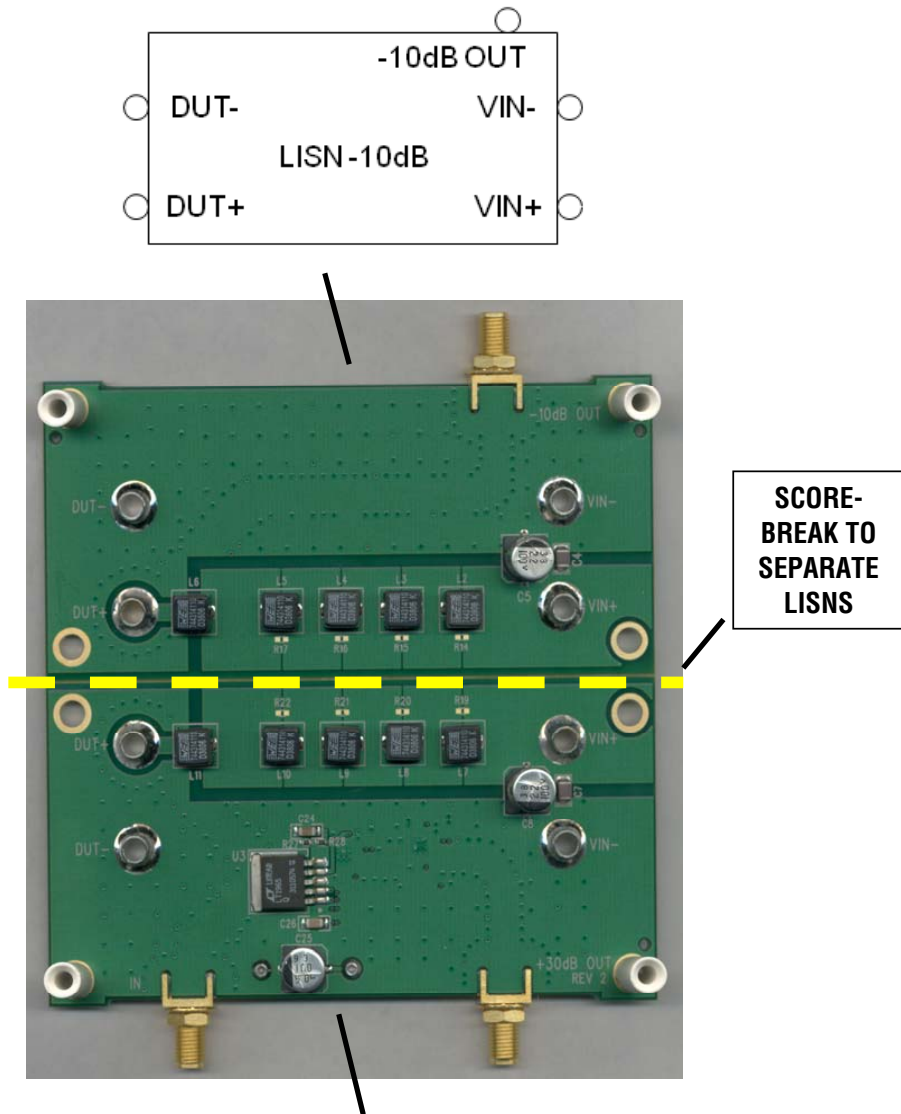

**AMPLIFIER
POWER
TERMINALS**

Bottom View

QUICK START PROCEDURE

-10dB LISN

To use the -10dB LISN of DC2130A for EMI testing on DC/DC converters, refer to Figure 1 for the proper measurement equipment setup and follow the procedure below:

NOTE: The limit for the input voltage is 60V for safety reasons even though the coupling capacitors C3 and C6 are rated to a higher voltage.

1. Connect the input supply (with power off), DUT and spectrum analyzer as shown.

2. Make the wire length from the LISN to the DUT as short as possible for pre-compliance tests to minimize pickup of outside signals and reduce impedance transformation for higher frequencies. When testing to a specific standard, make the wire length as specified by the standard.
3. Switch on the input supply and perform the measurements.

NOTE: Avoid connecting or disconnecting cables with the input supply on since inductive line transients can damage the measurement receiver input.

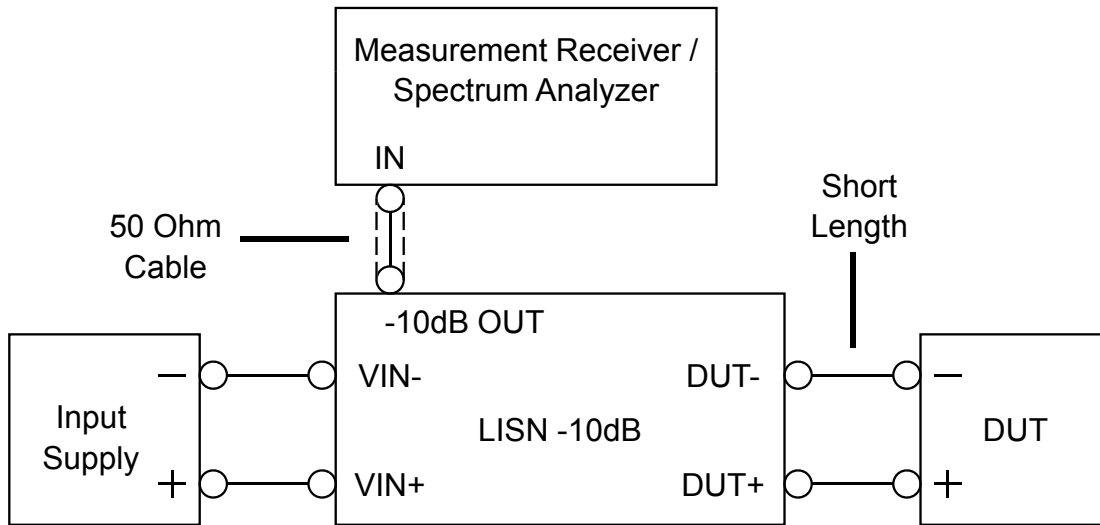

Figure 1. Proper Measurement Equipment Setup for DC2130A -10dB LISN

QUICK START PROCEDURE

+30dB LISN

To use the +30dB LISN of DC2130A for EMI testing on DC/DC converters, refer to Figure 2 for the proper measurement equipment setup and follow the procedure below:

NOTE: The limit for the input voltage is 60V for safety reasons even though the coupling capacitor C17 is rated to a higher voltage.

1. Make sure the coupling capacitor is soldered to the C17 pads and not the C21 pads.
2. Connect the input supply (with power off), DUT and spectrum analyzer as shown.
3. Make the wire length from the LISN to the DUT as short as possible for pre-compliance tests to minimize pickup of outside signals and reduce impedance transforma-

tion for higher frequencies. When testing to a specific standard, make the wire length as specified by the standard.

4. Connect a DC supply or a battery of 5.4V to 14V between the 5.4V-20V and GND terminals. The load from the two amplifier ICs is about 200mA total. There is a green LED on the board which should light up. If the supply is variable set it to 6V to limit unnecessary dissipation in U3 which is the LT1965 linear regulator.
5. Switch on the input supply and perform the measurements.

NOTE: Avoid connecting or disconnecting cables with the input supply on since inductive line transients can damage the measurement receiver input or the gain stage amplifier.

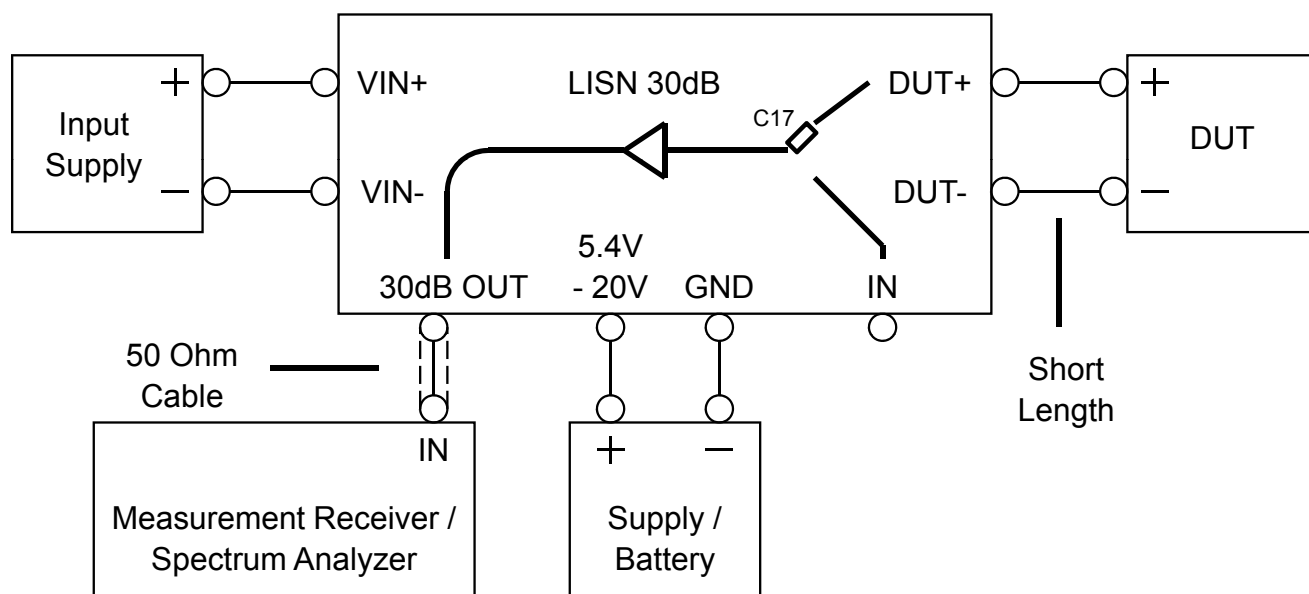

Figure 2. Proper Measurement Equipment Setup for DC2130A +30dB LISN

QUICK START PROCEDURE

+30dB Standalone Gain Stage

To use the +30dB standalone gain stage of DC2130A, refer to Figure 3 for the proper measurement equipment setup and follow the procedure below:

1. Make sure the coupling capacitor is soldered to the C21 pads and not the C17 pads.
2. Connect a DC supply or a battery of 5.4V to 14V between the 5.4V-20V and GND terminals. The load from the two

amplifier ICs is about 200mA total. There is a green LED on the board which should light up. If the supply is variable set it to 6V to limit unnecessary dissipation in U3 which is the LT1965 linear regulator.

3. Connect the spectrum analyzer as shown.
4. Connect the input source for amplification. The maximum amplitude is around 2V peak-to-peak and 20dBm at the output. See the LTC6431 data sheet for more details.

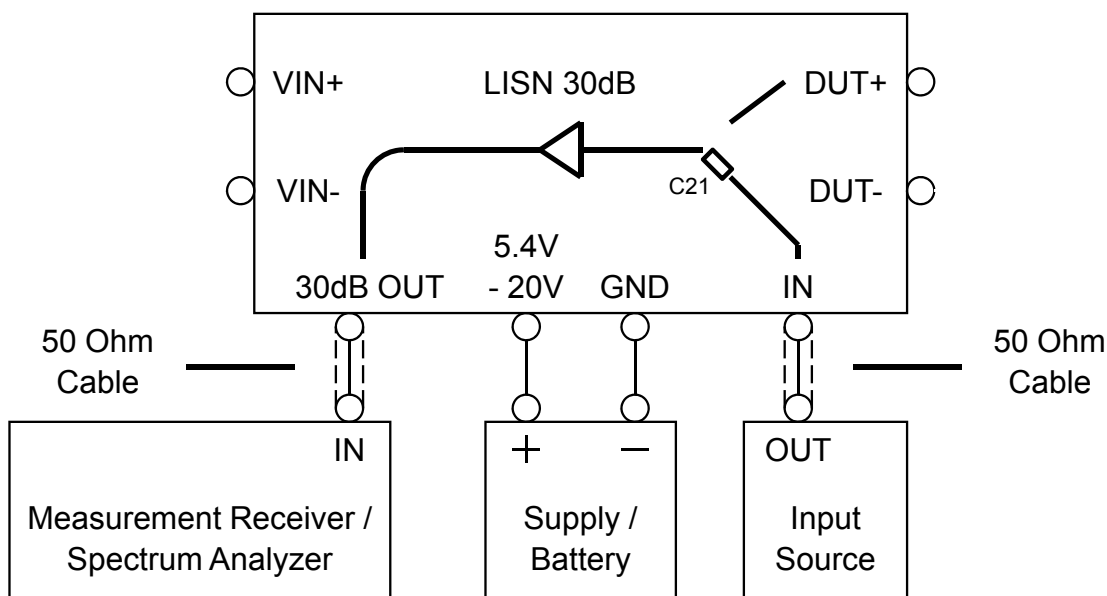

Figure 3. Proper Measurement Equipment Setup for DC2130A +30dB Standalone Gain Stage

QUICK START PROCEDURE

-10dB and +30dB LISNs, Common Mode Isolation

To use the -10dB and +30dB LISNs of DC2130A for EMI testing on DC/DC converters that cannot have one lead between the input supply and the DUT grounded, refer to Figure 4 for the proper measurement equipment setup and follow the procedure below:

NOTE 1: In Figure 4, polarized LISN capacitors C5 and C8 will be back-to-back and will not be effective as bulk capacitance for the input supply; therefore, add a 22 μ F 100V polarized capacitor between the two VIN+ terminals as shown in the Figure. Remove capacitors C5 and C8 if back-to-back capacitors are not desired. If un-removed, neither C5 nor C8 will be reverse-polarized at a damaging voltage.

NOTE 2: Avoid connecting or disconnecting cables with the input supply on since inductive line transients can damage the measurement receiver input.

1. Make sure the coupling capacitor is soldered to the C17 pads and not the C21 pads.

2. Connect the input supply (with power off), DUT and spectrum analyzer as shown.
3. VIN- between the two LISNs must be connected and the SMA connector that is unused and not connected to the measurement instrument must have a 50 Ω terminator added.
4. Make the wire length from the LISN to the DUT as short as possible for pre-compliance tests to minimize pickup of outside signals and reduce impedance transformation for higher frequencies. When testing to a specific standard, make the wire length as specified by the standard.
5. Connect a DC supply or a battery of 5.4V to 14V between the 5.4V-20V and GND terminals of the +30dB LISN. The load from the two amplifier ICs on the +30dB LISN is about 200mA total. There is a green LED on one LISN which should light up. If the supply is variable set it to 6V to limit unnecessary dissipation in U3 which is the LT1965 linear regulator.
6. Switch on the input supply and perform the measurements.

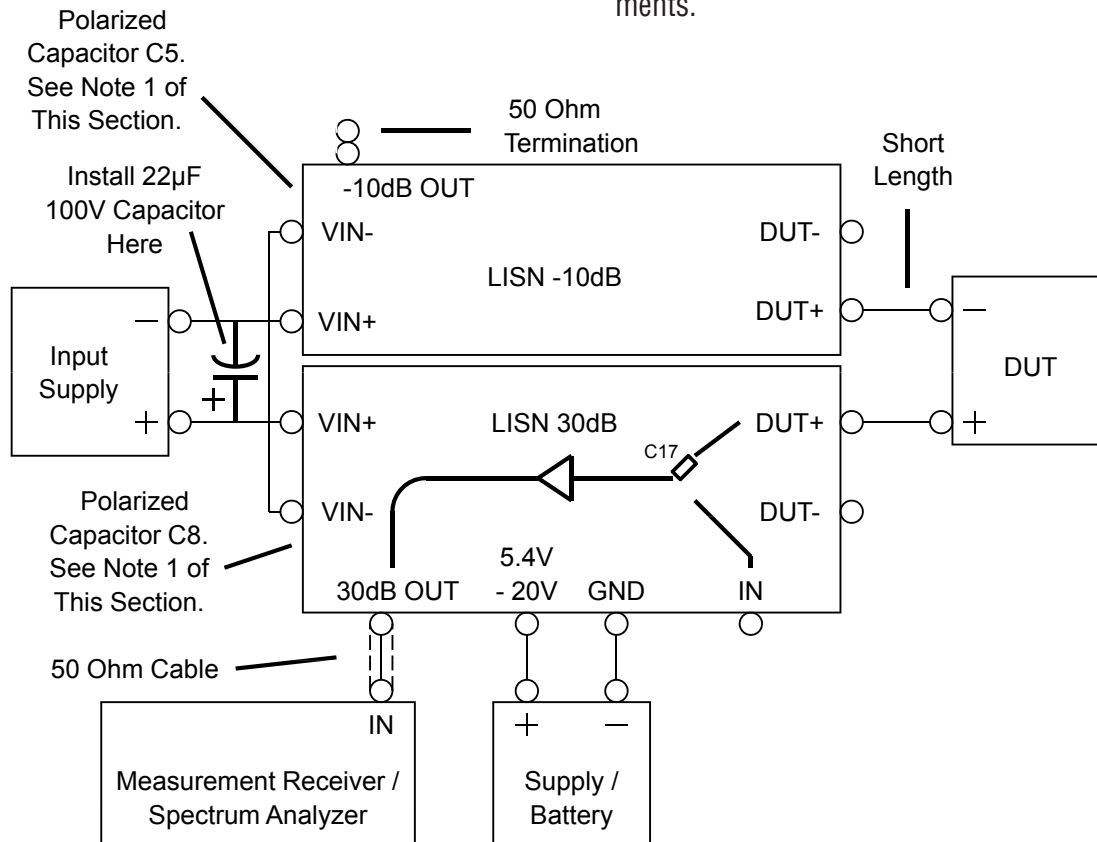

Figure 4. Proper Measurement Equipment Setup for DC2130A -10dB and +30dB LISNs with Common Mode Isolation

dc2130af

QUICK START PROCEDURE

-10dB LISNs, Common Mode Isolation

To use two -10dB LISNs of DC2130A for EMI testing on DC/DC converters that cannot have one lead between the input supply and the DUT grounded, refer to Figure 5 for the proper measurement equipment setup and follow the procedure below:

NOTE 1: In Figure 5, polarized capacitors C5 on each LISN will be back-to-back and will not be effective as bulk capacitance for the input supply; therefore, add a 22µF 100V polarized capacitor between the two VIN+ terminals as shown in the Figure. Remove capacitor C5 from both LISNs if back-to-back capacitors are not desired. If un-removed, neither C5 will be reverse-polarized at a damaging voltage.

NOTE 2: Avoid connecting or disconnecting cables with the input supply on since inductive line transients can damage the measurement receiver input.

1. Connect the input supply (with power off), DUT and spectrum analyzer as shown.
2. VIN- between the two LISNs must be connected and the SMA connector that is unused and not connected to the measurement instrument must have a 50Ω terminator added.
3. Make the wire length from the LISN to the DUT as short as possible for pre-compliance tests to minimize pickup of outside signals and reduce impedance transformation for higher frequencies. When testing to a specific standard, make the wire length as specified by the standard.
4. Switch on the input supply and perform the measurements.

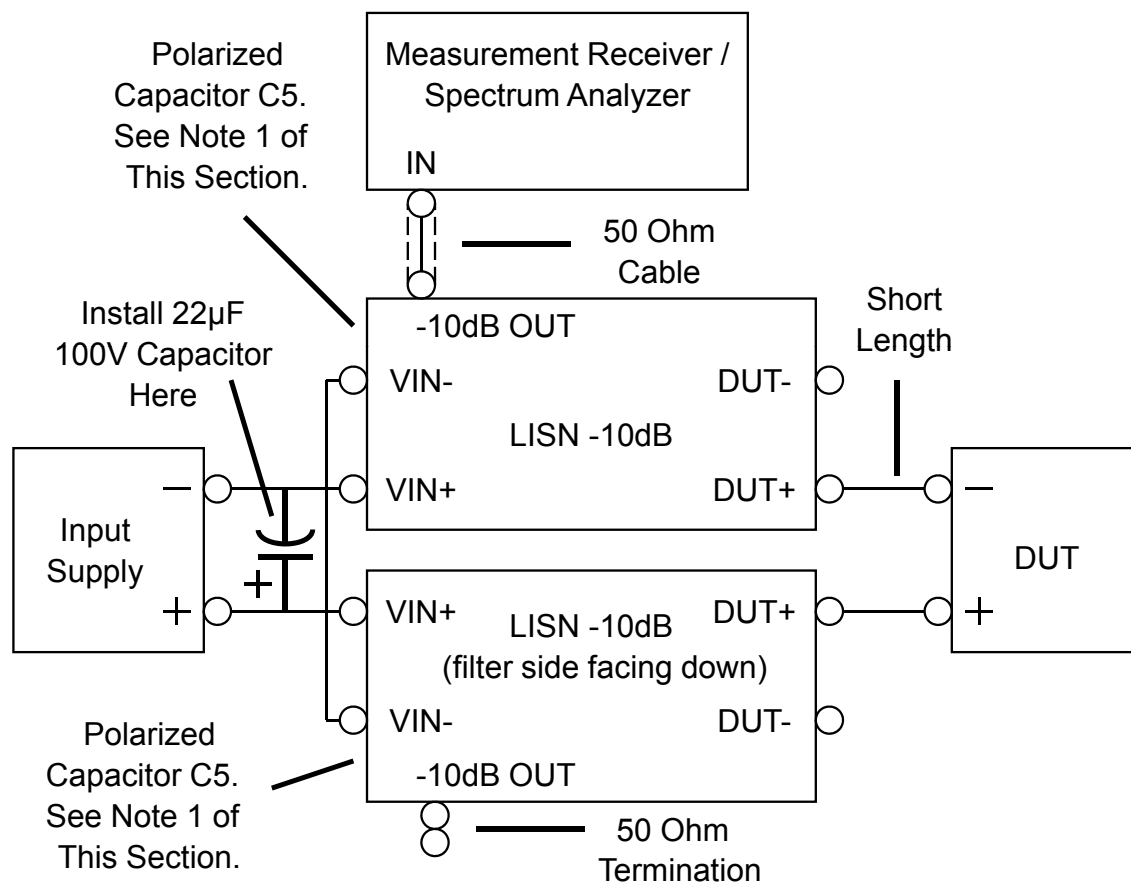

Figure 5. Proper Measurement Equipment Setup for DC2130A -10dB LISNs with Common Mode Isolation (Requires a Separate DC2130A for Each -10dB LISN)

QUICK START PROCEDURE

+30dB LISNs, Common Mode Isolation

To use two +30dB LISNs of DC2130A for EMI testing on DC/DC converters that cannot have one lead between the input supply and the DUT grounded, refer to Figure 6 for the proper measurement equipment setup and follow the procedure below:

NOTE 1: In Figure 6, polarized capacitors C8 on each LISN will be back-to-back and will not be effective as bulk capacitance for the input supply; therefore, add a 22 μ F 100V polarized capacitor between the two VIN+ terminals as shown in the Figure. Remove capacitors C8 from both LISNs if back-to-back capacitors are not desired. If un-removed, neither C8 will be reverse-polarized at a damaging voltage.

NOTE 2: Avoid connecting or disconnecting cables with the input supply on since inductive line transients can damage the measurement receiver input.

1. Make sure the coupling capacitors are soldered to the C17 pads and not the C21 pads.

2. Connect the input supply (with power off), DUT and spectrum analyzer as shown.
3. VIN- between the two LISNs must be connected and the SMA connector that is unused and not connected to the measurement instrument must have a 50 Ω terminator added.
4. Make the wire length from the LISN to the DUT as short as possible for pre-compliance tests to minimize pickup of outside signals and reduce impedance transformation for higher frequencies. When testing to a specific standard, make the wire length as specified by the standard.
5. Connect a DC supply or a battery of 5.4V to 14V between the 5.4V-20V and GND terminals of both LISNs. The load from the two amplifier ICs on each LISN is about 200mA total. There is a green LED on each LISN which should light up. If the supply is variable set it to 6V to limit unnecessary dissipation in U3 which is the LT1965 linear regulator.
6. Switch on the input supply and perform the measurements.

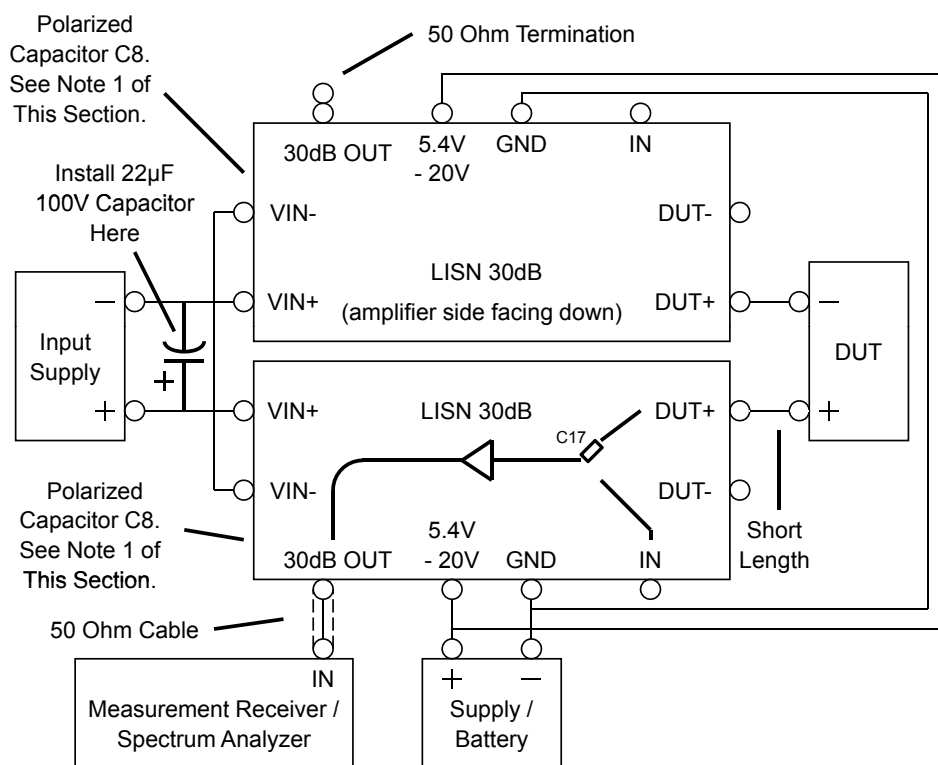

Figure 6. Proper Measurement Equipment Setup for DC2130A +30dB LISNs with Common Mode Isolation (Requires a Separate DC2130A for Each +30dB LISN)

QUICK START PROCEDURE

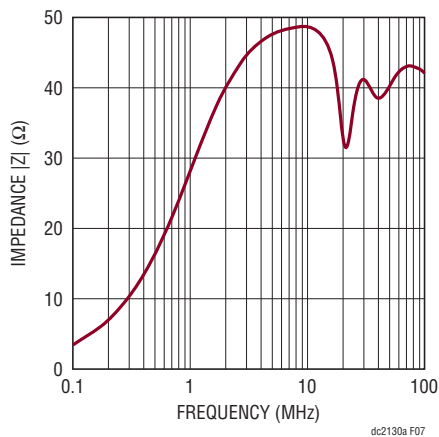

Figure 7. -10dB LISN Impedance Magnitude $|Z|$ at the DUT Terminals from 100kHz to 100MHz

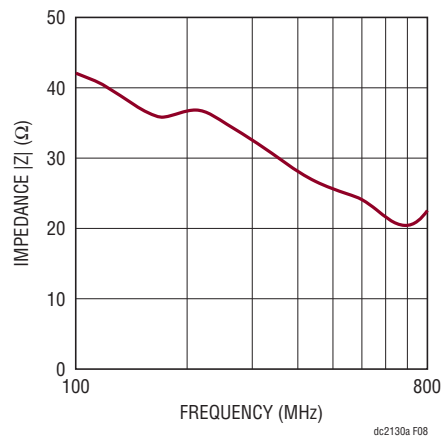

Figure 8. -10dB LISN Impedance Magnitude $|Z|$ at the DUT Terminals from 100MHz to 800MHz

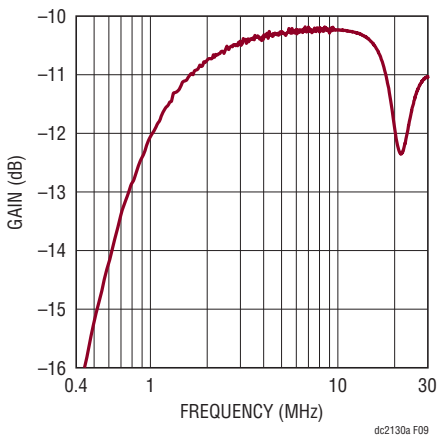

Figure 9. -10dB LISN Gain from the DUT Terminals to -10dB OUT from 500kHz to 30MHz

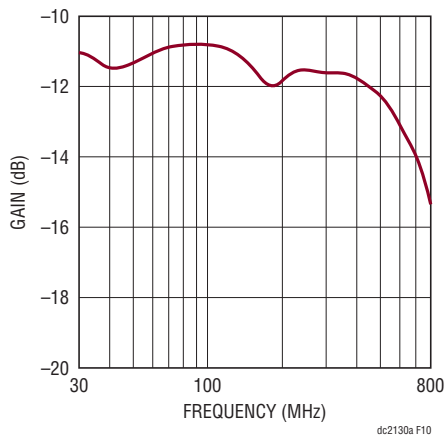

Figure 10. -10dB LISN Gain from the DUT Terminals to -10dB OUT from 30MHz to 800MHz

QUICK START PROCEDURE

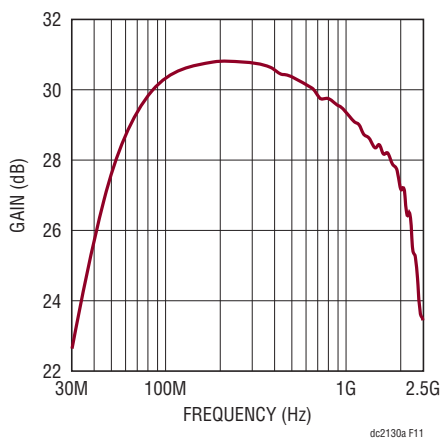

Figure 11. +30dB Amplifier Gain from IN to +30dB OUT from 30MHz to 2.5GHz

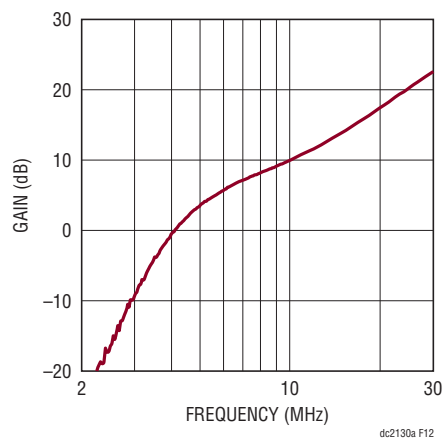

Figure 12. +30dB Amplifier Gain from IN to +30dB OUT from 2MHz to 30MHz

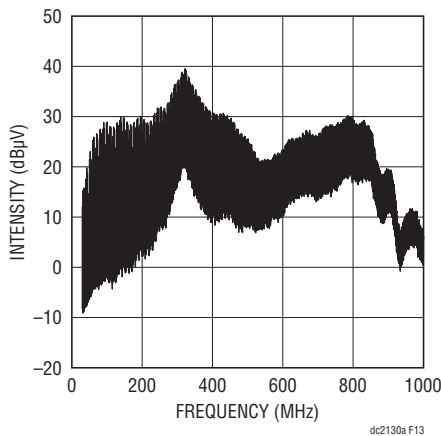

Figure 13. This 30MHz to 1GHz Scan with the +30dB LISN Makes the Conducted EMI of DC2019A Featuring the LT8614 Silent Switcher Visible Above the Noise Floor. The Input Voltage is 24V and the Load is 5V at 4A.

MODIFICATIONS AND OTHER USES

Increase Maximum DUT Current

The DC2130A ferrite inductors can be replaced with an air coil to increase the maximum DUT current beyond 10A. Copper wire wound over a 30mm diameter rod with 18 windings and a 70mm length gives 5 μ H of inductance. All dimensions can be altered as long as the inductor is 5 μ H. It is easiest to adjust the inductance by changing the length or removing some windings. Current limit is then determined only by the copper wire thermals. Air coils have more resonances in the higher frequency range above 100MHz than ferrite inductors. The air coils should be damped by placing a resistor over a part of the winding. In Figure 14 a 270 Ω resistor is used over 1/2 of the windings from the VIN side. This works for both the -10dB and +30dB LISNs. Resonances should be checked with a vector network analyzer with a short pigtail soldered on the DUT side as shown in Figure 14.

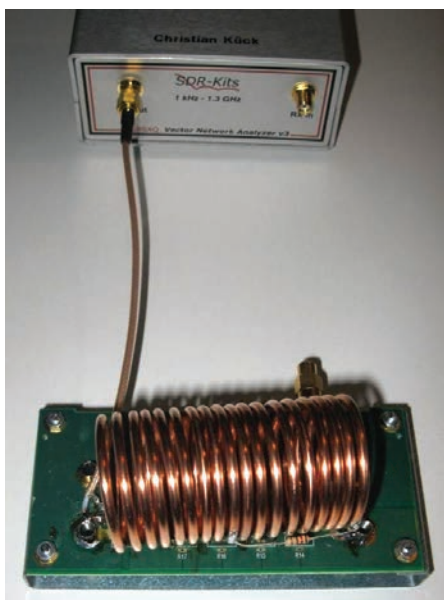

Figure 14. 18 Turn Air Coil Inductor with 6mm² Diameter Copper Wire, 70mm Length and a 270 Ω Damping Resistor Over 1/2 of the Windings

Utilizing the +30db Low Noise Amplifier

Beside its use as LISN preamplifier the +30dB wideband low noise amplifier can be used as a general purpose preamplifier for a spectrum analyzer. Its 3dB to 4dB noise figure can be utilized to amplify the signal of magnetic probes like the Tektronix CT1 or CT6 as well as magnetic sniffer probes. The low noise figure enables the use of single turn sniffer probes.

A single turn sniffer probe can be easily fabricated from any 50 Ω coaxial cable by making a single turn with the inner conductor that is a few mm in diameter and then soldering the inner conductor to the cable shield. A heat shrink tube over the solder joint will prevent accidental shorts to GND while probing. The single turn source impedance is low compared to 50 Ω so the sniffer probe can be connected directly to the amplifier input SMA connector.

Improve -10B LISN Gain and Impedance versus Frequency

The extra attenuation that occurs around 22MHz on the -10dB LISN and is apparent in Figures 7 and 9 is caused by the resonance from the 1.1 μ H L2-L6 inductors and the pcb pad area capacitance. The attenuation is about 2dB when measured by a 50 Ω source. The resonance can be eliminated by removing the inductors from the pcb and soldering L2-L6 in the air with connections only at the DUT+ and VIN+ jacks. The maximum DUT current will require derating from 10A because the thermal resistance of the inductors increases when they are mounted in the air, but ferrite inductors have the advantage of no high-Q resonances at frequencies above 100MHz compared to air coils.

MODIFICATIONS AND OTHER USES

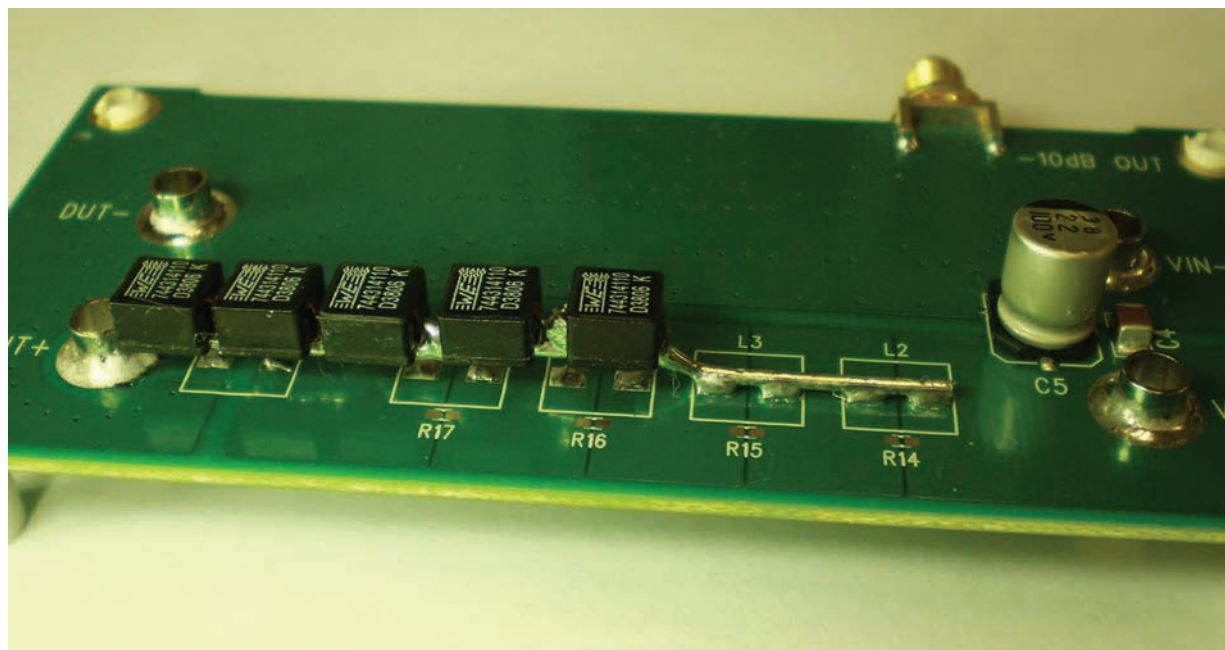

Figure 15. L2 to L6 Are Mounted in the Air to Improve the Gain and Impedance versus Frequency Characteristics for the -10dB LISN

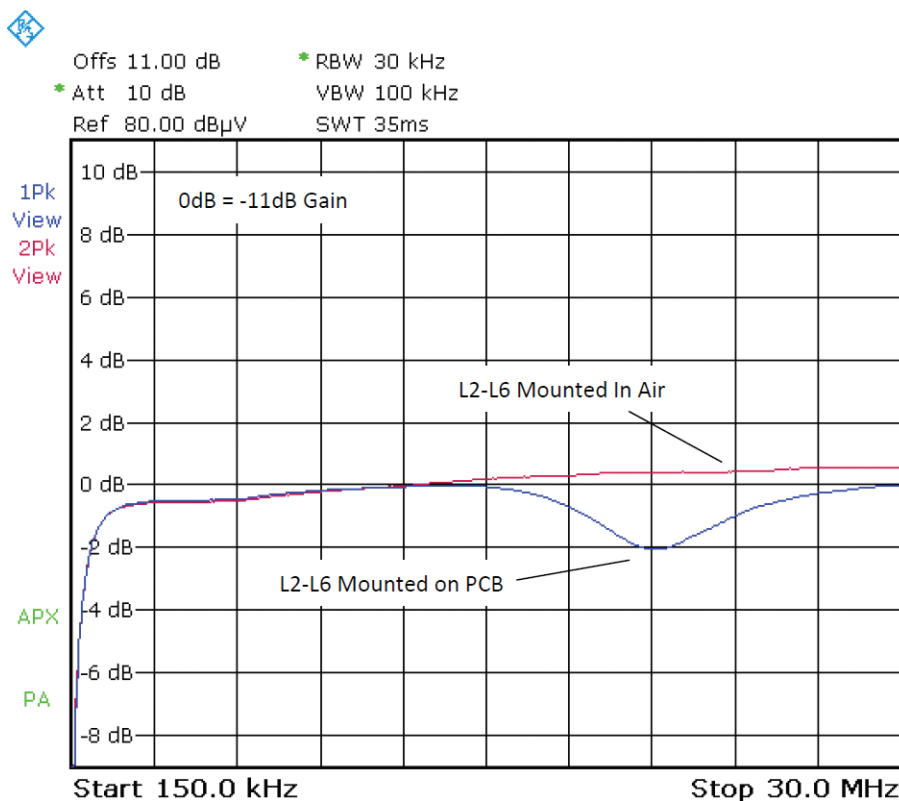

Figure 16. Improvement that Occurs in the Gain Characteristics when Inductors L2 to L6 for the -10dB LISN are Mounted in the Air Compared to Mounting Them on the PCB

DEMO MANUAL DC2130A

PARTS LIST

ITEM	QTY	REFERENCE	PART DESCRIPTION	MANUFACTURER/PART NUMBER
Required Circuit Components				
1	2	C1, C2	CAP., X7R, 0.47µF, 25V, 10% 0805	MURATA, GRM21BR71E474KA01
2	2	C3, C6	CAP., X7R, 0.10µF, 250V, 10% 1206	MURATA, GRM31CR72E104KW03L
3	2	C4, C7	CAP., X7S, 4.7µF, 100V, 20% 1210	TDK, C3225X7S2A475M
4	2	C5, C8	CAP., ALUM. ELEC., 22µF, 100V, 8x10.2	SUN ELECT, 100CE22BS
5	2	C9, C12	CAP., X7R, 0.1µF, 16V, 10% 0603	AVX, 0603YC104KAT2A
6	9	C10, C11, C13 - C16, C19, C20, C22	CAP., X7R, 1000pF, 16V, 10% 0402	AVX, 0402YC102KAT2A
7	1	C21	CAP., COG, 1000pF, 200V, 10% 1206	AVX, 12062A102KAT2A
8	2	C18, C23	CAP., COG, 62pF, 25V, 5% 0402	AVX, 04023A620JAT
9	1	C24	CAP., X5R, 47µF, 6.3V, 10% 1206	MURATA, GRM31CR60J476KE19L
10	1	C25	CAP., ALUM. ELEC., 100µF, 50V, 8x10.2	SUN ELECT, 50CE100LX
11	1	C26	CAP., X7R, 10µF, 25V, 10% 1206	MURATA, GRM31CR71E106KA12
12	4	D1 - D4	DIODE, SWITCH 100V 400MW, SOD123	DIODES, 1N4148W-7-F
13	1	D5	LED, 0603, GREEN	OSRAM, LG L29K-G2J1-24-Z
14	1	L1	INDUCTOR 1000µH 10% 0.15X0.15 SMD	COILCRAFT, 1008PS-105LKB
15	10	L2 - L11	INDUCTOR 1.1µH, 20%, SMD	WURTH, 744314110
16	3	L12 - L14	INDUCTOR 0.56µH, 5%, 0603LS-1608	COILCRAFT, 0603LS-561XJLB
17	1	R1	RES., CHIP, 825Ω, 1/10W, 1% 0603	VISHAY, CRCW0603825RFKEA
18	1	R2	RES., CHIP, 243Ω, 1/10W, 1% 0603	VISHAY, CRCW0603243RFKEA
19	4	R3, R4, R11, R12	RES., CHIP, 432Ω, 1/10W, 1% 0603	VISHAY, CRCW0603432RFKEA
20	1	R5	RES., CHIP, 562Ω, 1/10W, 1% 0603	VISHAY, CRCW0603562RFKEA
21	1	R6	RES., CHIP, 12.1Ω, 1/10W, 1% 0603	VISHAY, CRCW060312R1FKEA
22	1	R7	RES., CHIP, 30.1Ω, 1/10W, 1% 0603	VISHAY, CRCW060330R1FKEA
23	1	R8	RES., CHIP, 18.2Ω, 1/10W, 1% 0603	VISHAY, CRCW060318R2FKEA
24	1	R9	RES., CHIP, 909Ω, 1/10W, 1% 0603	VISHAY, CRCW0603909RFKEA
25	1	R10	RES., CHIP, 274Ω, 1/10W, 1% 0603	VISHAY, CRCW0603274RFKEA
26	1	R13	RES., CHIP, 619Ω, 1/10W, 1% 0603	VISHAY, CRCW0603619RFKEA
27	2	R24, R25	RES., CHIP, 348Ω, 1/10W, 1% 0402	VISHAY, CRCW0402348RFKED
28	1	R26	RES., CHIP, 330Ω, 1/10W, 5% 0603	VISHAY, CRCW0603331JNEA
29	1	R27	RES., CHIP, 10.2k, 1/10W, 1% 0603	VISHAY, CRCW060310K2FKEA
30	1	R28	RES., CHIP, 32.4k, 1/10W, 1% 0603	VISHAY, CRCW060332K4FKEA
31	2	U1, U2	IC AMP GAIN BLOCK 24-QFN	LINEAR, LTC6431AIUF-15#PBF
32	1	U3	IC REG LDO ADJ 1.1A D2PAK	LINEAR, LT1965EQ#PBF
Additional Demo Board Circuit Components				
1	0	C17	CAP., 1206, OPT	AVX, 12062A102KAT2A
2	0	R14 - R17, R19 - R22	RES., CHIP, 0603, OPT	
Hardware: For Demo Board Only				
1	2	E1 - E2	TESTPOINT, TURRET, 0.094" pbf	MILL-MAX, 2501-2-00-80-00-00-07-0
2	3	J1 - J3	CONN SMA JACK 50Ω EDGE MNT	EMERSON, 142-0701-871
3	8	J4 - J11	BANANA JACK NON-INSULATED 0.218	KEYSTONE, 575-4
4	4	MH1 - MH4	STANDOFF, NYLON 0.50"	KEYSTONE, 8833 (SNAP-ON)
5	0	MH5 - MH8	STANDOFF, NYLON 0.50", OPT	KEYSTONE, 8833 (SNAP-ON)

SCHEMATIC DIAGRAM

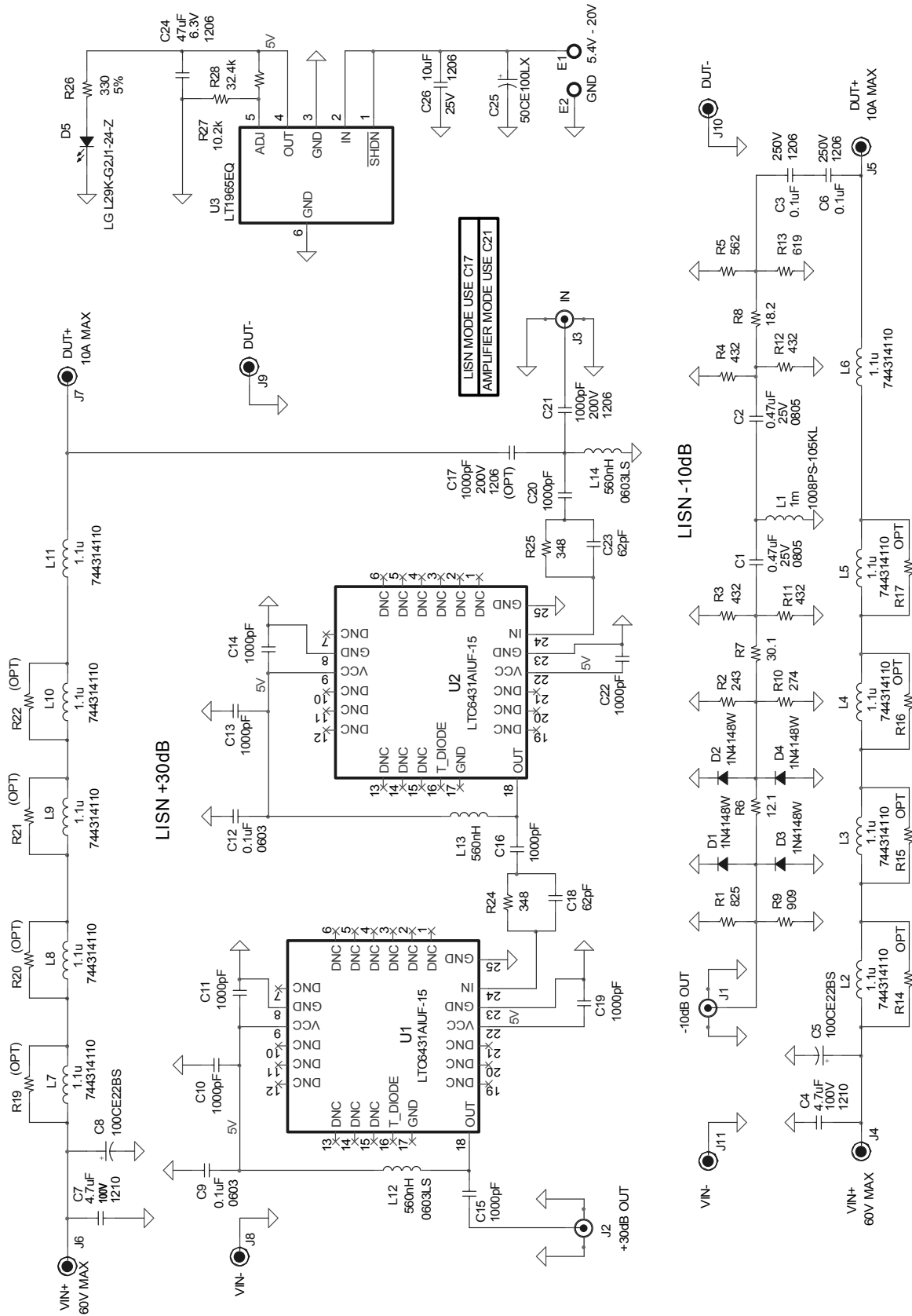

DEMO MANUAL DC2130A

DEMONSTRATION BOARD IMPORTANT NOTICE

Linear Technology Corporation (LTC) provides the enclosed product(s) under the following **AS IS** conditions:

This demonstration board (DEMO BOARD) kit being sold or provided by Linear Technology is intended for use for **ENGINEERING DEVELOPMENT OR EVALUATION PURPOSES ONLY** and is not provided by LTC for commercial use. As such, the DEMO BOARD herein may not be complete in terms of required design-, marketing-, and/or manufacturing-related protective considerations, including but not limited to product safety measures typically found in finished commercial goods. As a prototype, this product does not fall within the scope of the European Union directive on electromagnetic compatibility and therefore may or may not meet the technical requirements of the directive, or other regulations.

If this evaluation kit does not meet the specifications recited in the DEMO BOARD manual the kit may be returned within 30 days from the date of delivery for a full refund. **THE FOREGOING WARRANTY IS THE EXCLUSIVE WARRANTY MADE BY THE SELLER TO BUYER AND IS IN LIEU OF ALL OTHER WARRANTIES, EXPRESSED, IMPLIED, OR STATUTORY, INCLUDING ANY WARRANTY OF MERCHANTABILITY OR FITNESS FOR ANY PARTICULAR PURPOSE. EXCEPT TO THE EXTENT OF THIS INDEMNITY, NEITHER PARTY SHALL BE LIABLE TO THE OTHER FOR ANY INDIRECT, SPECIAL, INCIDENTAL, OR CONSEQUENTIAL DAMAGES.**

The user assumes all responsibility and liability for proper and safe handling of the goods. Further, the user releases LTC from all claims arising from the handling or use of the goods. Due to the open construction of the product, it is the user's responsibility to take any and all appropriate precautions with regard to electrostatic discharge. Also be aware that the products herein may not be regulatory compliant or agency certified (FCC, UL, CE, etc.).

No License is granted under any patent right or other intellectual property whatsoever. **LTC assumes no liability for applications assistance, customer product design, software performance, or infringement of patents or any other intellectual property rights of any kind.**

LTC currently services a variety of customers for products around the world, and therefore this transaction **is not exclusive**.

Please read the DEMO BOARD manual prior to handling the product. Persons handling this product must have electronics training and observe good laboratory practice standards. **Common sense is encouraged.**

This notice contains important safety information about temperatures and voltages. For further safety concerns, please contact a LTC application engineer.

Mailing Address:

Linear Technology
1630 McCarthy Blvd.
Milpitas, CA 95035

Copyright © 2004, Linear Technology Corporation

X-ON Electronics

Largest Supplier of Electrical and Electronic Components

Click to view similar products for [Power Management IC Development Tools](#) category:

Click to view products by [Analog Devices](#) manufacturer:

Other Similar products are found below :

[EVAL-ADM1168LQEBZ](#) [EVB-EP5348UI](#) [MIC23451-AAAYFL EV](#) [MIC5281YMME EV](#) [DA9063-EVAL](#) [ADP122-3.3-EVALZ](#) [ADP130-0.8-EVALZ](#) [ADP130-1.2-EVALZ](#) [ADP130-1.5-EVALZ](#) [ADP130-1.8-EVALZ](#) [ADP1714-3.3-EVALZ](#) [ADP1716-2.5-EVALZ](#) [ADP1740-1.5-EVALZ](#) [ADP1752-1.5-EVALZ](#) [ADP1828LC-EVALZ](#) [ADP1870-0.3-EVALZ](#) [ADP1871-0.6-EVALZ](#) [ADP1873-0.6-EVALZ](#) [ADP1874-0.3-EVALZ](#) [ADP1882-1.0-EVALZ](#) [ADP199CB-EVALZ](#) [ADP2102-1.25-EVALZ](#) [ADP2102-1.875EVALZ](#) [ADP2102-1.8-EVALZ](#) [ADP2102-2-EVALZ](#) [ADP2102-3-EVALZ](#) [ADP2102-4-EVALZ](#) [ADP2106-1.8-EVALZ](#) [ADP2147CB-110EVALZ](#) [AS3606-DB](#) [BQ24010EVM](#) [BQ24075TEVM](#) [BQ24155EVM](#) [BQ24157EVM-697](#) [BQ24160EVM-742](#) [BQ24296MEVM-655](#) [BQ25010EVM](#) [BQ3055EVM](#) [NCV891330PD50GEVB](#) [ISLUSBI2CKIT1Z](#) [LM2744EVAL](#) [LM2854EVAL](#) [LM3658SD-AEV/NOPB](#) [LM3658SDEV/NOPB](#) [LM3691TL-1.8EV/NOPB](#) [LM4510SDEV/NOPB](#) [LM5033SD-EVAL](#) [LP38512TS-1.8EV](#) [EVAL-ADM1186-1MBZ](#) [EVAL-ADM1186-2MBZ](#)