

Dual 42V Synchronous Monolithic Step-Down Regulator with 6.5 μ A Quiescent Current

DESCRIPTION

Demonstration circuit 2169A is a dual monolithic step-down DC/DC switching regulator featuring the LT[®]8616. The LT8616 is a high efficiency, high speed, dual synchronous monolithic step-down switching regulator that consumes only 6.5 μ A of quiescent current with both channels enabled. The demo circuit is designed for 5V, 1.5A and 3.3V, 2.5A outputs. Both channels contain all switches and necessary circuitry to minimize the external components and solution size. Fast minimum ON time of 35ns enables high V_{IN} to low V_{OUT} conversion at high switching frequency. Independent input voltage, feedback, soft-start and power good pins for each channel simplify complex power supply tracking/sequencing requirements.

The inputs of the two channels are connected on the demo board by default. They can also be separated by removing the 0 Ω resistor (R13) from the board. Each output can be independently disabled using its own EN/UV pin, while V_{IN1} must be connected to 3.4V or above even if only channel 2 is in use. The demo board has an EMI filter installed between V_{IN2} and V_{EMI} . To use the EMI filter, the inputs should be tied to V_{EMI} .

The switching frequency of both channels can be programmed either via an oscillator resistor or a common external clock up to 3MHz. The SYNC pin on the demo board is grounded by default for Burst Mode[®] operation.

To synchronize to an external clock, move JP1 to SYNC/MODE and apply the external clock to the SYNC/MODE turret. The R_T resistor (R5) should be chosen to set the LT8616 internal switching frequency at least 20% below the lowest synchronization input.

Low ripple Burst Mode operation increases the efficiency at the light load while keeping the output ripple low. Figure 1 and Figure 2 show the demo board efficiency for each channel at 12V input voltage in Burst Mode operation. Figure 3 shows the temperature rising on DC2169A demo board with different input voltages under full load conditions on both channels.

The LT8616 data sheet gives a complete description of the part, operation and application information. The data sheet must be read in conjunction with this demo manual for DC2169A. The LT8616 is assembled in a 28-lead plastic TSSOP package. Proper board layout is essential for both low EMI operation and maximum thermal performance. See the data sheet sections for details.

Design files for this circuit board are available at <http://www.linear.com/demo/DC2169A>

LT, LT, LTC, LTM, Linear Technology, the Linear logo and Burst Mode are registered trademarks of Linear Technology Corporation. All other trademarks are the property of their respective owners.

PERFORMANCE SUMMARY Specifications are at $T_A = 25^\circ\text{C}$

SYMBOL	PARAMETER	CONDITIONS	MIN	TYP	MAX	UNITS
V_{IN1}	Channel 1 Input Supply Range		5.8		42	V
V_{IN2}	Channel 2 Input Supply Range		4.1		42	V
V_{OUT1}	Channel 1 Output Voltage		4.88	5.02	5.15	V
V_{OUT2}	Channel 2 Output Voltage		3.21	3.29	3.37	V
f_{SW}	Switching Frequency	$R_T = 14.7\text{k}\Omega$	1.85	2.05	2.25	MHz
I_{OUT1}	Channel 1 Max Output Current		1.5			A
I_{OUT2}	Channel 2 Max Output Current		2.5			A
EFE	Efficiency at DC	$V_{IN1} = V_{IN2} = 12\text{V}$, $I_{OUT1} = 1.5\text{A}$, $I_{OUT2} = 2.5\text{A}$		85.1		%

PERFORMANCE SUMMARY

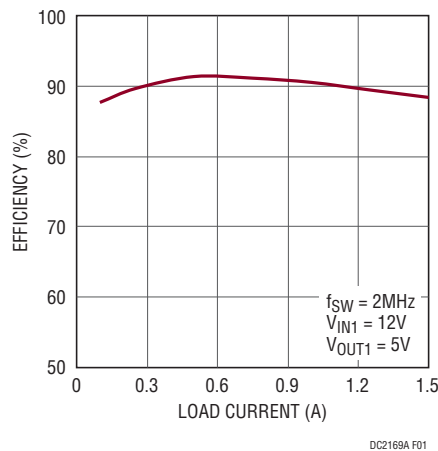

Figure 1. LT8616 Channel 1 Efficiency vs Load Current

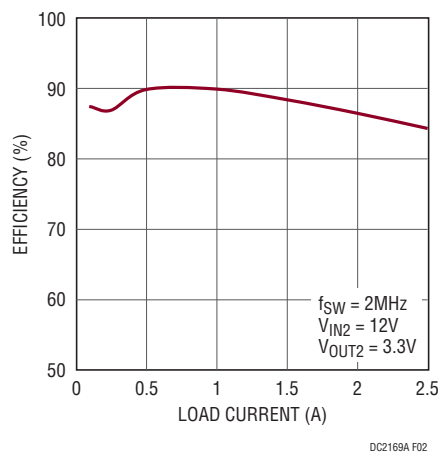

Figure 2. LT8616 Channel 2 Efficiency vs Load Current

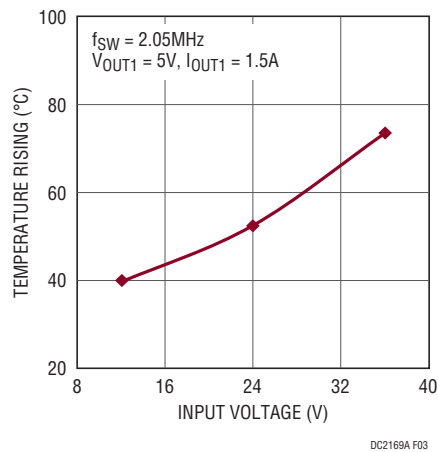

Figure 3. LT8616 Temperature Rising vs Input Voltage

QUICK START PROCEDURE

DC2169A is easy to set up to evaluate the performance of the LT8616. Refer to Figure 4 for proper measurement equipment setup and follow the procedure below:

NOTE: When measuring the input or output voltage ripple, care must be taken to avoid a long ground lead on the oscilloscope probe. Measure the input or output voltage ripple by touching the probe tip directly across the V_{IN} or V_{OUT} and GND terminals. See Figure 5 for the proper scope technique.

1. Place JP1 on the Burst Mode position.
2. With power off, connect the input power supply to V_{EMI} and GND. Make sure that the input voltage does not exceed 42V.
3. With power off, connect loads from V_{OUT1} to GND, and V_{OUT2} to GND.

4. Turn on the power at the input.
5. Check for the proper output voltages (5V and 3.3V).

NOTE: If there is no output, temporarily disconnect the load to make sure that the load is not set too high or is shorted.

6. Once the proper output voltages are established, adjust the load within the operating ranges and observe the output voltage regulation, ripple voltage, efficiency and other parameters.
7. An external clock can be added to the SYNC terminal when SYNC function is used (JP1 on the SYNC/MODE position). Please make sure that the SYNC frequency is at least 20% higher than the set switching frequency. See the data sheet section Synchronization.

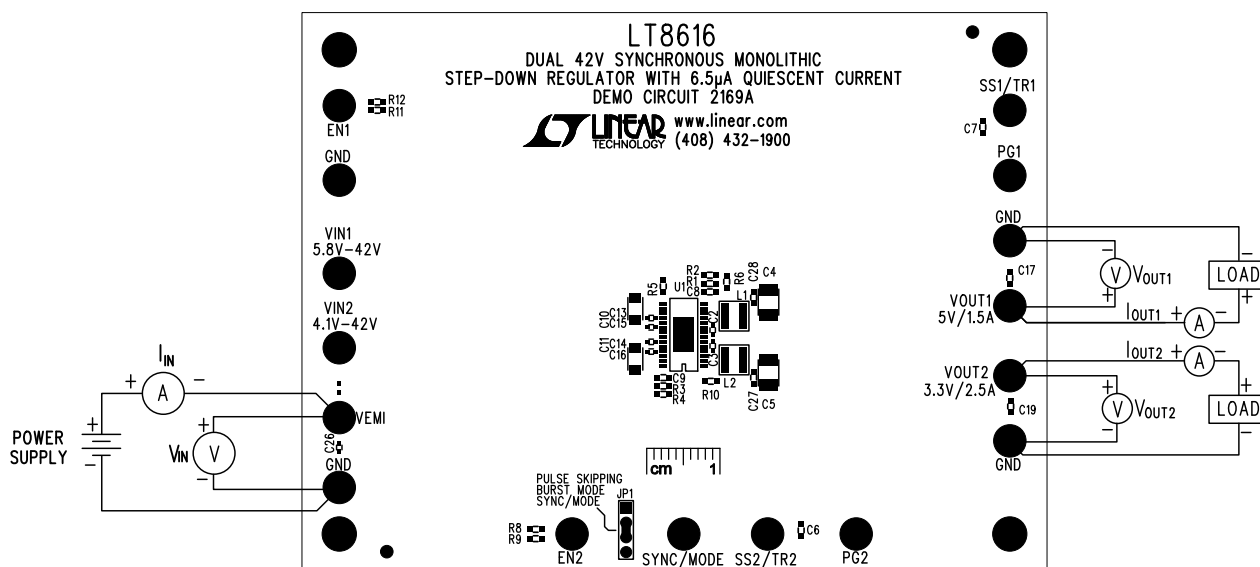

Figure 4. Proper Measurement Equipment Setup

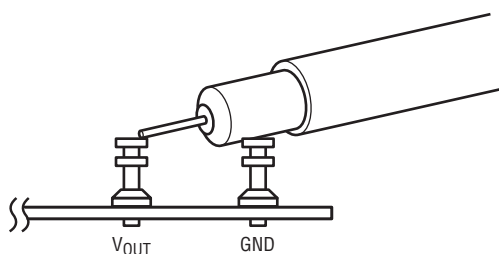

Figure 5. Measuring Input or Output Ripple

DEMO MANUAL DC2169A

PARTS LIST

ITEM	QTY	REFERENCE	PART DESCRIPTION	MANUFACTURER/PART NUMBER
Required Circuit Components				
1	2	C2, C3	CAP., X7R, 0.1 μ F, 10V, 10% 0402	SAMSUNG, CL05B104KP5NUNC
2	1	C4	CAP., X7R, 22 μ F, 10V, 10% 1210	MURATA, GRM32ER71A226KE20L
3	1	C5	CAP., X7R, 47 μ F, 10V, 10% 1210	MURATA, GRM32ER71A476KE15L
4	2	C6, C7	CAP., X7R, 0.01 μ F, 10V, 10% 0603	AVX, 0603ZC103KAT2A
5	2	C8, C9	CAP., COG, 4.7pF, 50V, \pm 0.25pF 0603	AVX, 06035A4R7CAT2A
6	2	C10, C11	CAP., X7R, 2.2 μ F, 50V, 10% 1206	MURATA, GRM31CR71H225KA88L
7	5	C12, C17, C19, C27, C28	CAP., X7R, 1 μ F, 10V, 10% 0603	AVX, 0603ZC105KAT2A
8	4	C13, C14, C15, C16	CAP., X7R, 0.1 μ F, 50V, 10% 0402	TDK, C1005X7R1H104K050BB
9	1	L1	IND., 3.3 μ H, XAL4030	COILCRAFT, XAL4030-332ME
10	1	L2	IND., 2.2 μ H, XFL4020	COILCRAFT, XFL4020-222ME
11	6	R1, R3, R6, R8, R10, R11	RES., CHIP, 1M, 0.1W, 1%, 0603	VISHAY, CRCW06031M00FKEA
12	1	R2	RES., CHIP, 187k, 0.1W, 1%, 0603	VISHAY, CRCW0603187KFKEA
13	1	R4	RES., CHIP, 316k, 0.1W, 1%, 0603	VISHAY, CRCW0603316KFKEA
14	1	R5	RES., CHIP, 14.7k, 0.1W, 1%, 0603	VISHAY, CRCW060314K7FKEA
15	2	R7, R13	RES., CHIP, 0 Ω , 0.1W, 0603	VISHAY, CRCW06030000Z0EA
16	1	U1	IC., LT8616EFE TSSOP-28/EB	LINEAR TECH., LT8616EFE#PBF
Additional Demo Board Circuit Components				
1	2	C1, C18	CAP., ALUM., 22 μ F, 63V,	SUN ELECTRONIC INDUSTRIES CORP., 63CE22BS
2	1	L3	CHIP BEAD, 30 Ω , MPZ2012	TDK, MPZ2012S300AT
3	1	L4	IND., 0.22 μ H, IHLP1212AB	VISHAY, IHLP1212ABERR22M11
4	1	C23	CAP., X7R, 4.7 μ F, 50V, 10% 1206	SAMSUNG, CL31B475KBHNNNE
5	1	C24	CAP., X7R, 10 μ F, 50V, 10% 1210	MURATA, GRM32ER71H106KA12L
6	2	C25, C26	CAP., X7R, 0.1 μ F, 50V, 10% 0402	TDK, C1005X7R1H104K050BB
7	0	R9, R12 (OPT)	RES., CHIP, 0603	
Hardware: For Demo Board Only				
1	16	E1-E16	TESTPOINT, TURRET, .094" PBF	MILL-MAX, 2501-2-00-80-00-00-07-0
2	1	JP1	4 PIN 0.079 SINGLE ROW HEADER	SULLINS, NRPN041PAEN-RC
3	1	XJP1	SHUNT, .079" CENTER	SAMTEC, 2SN-BK-G

SCHEMATIC DIAGRAM

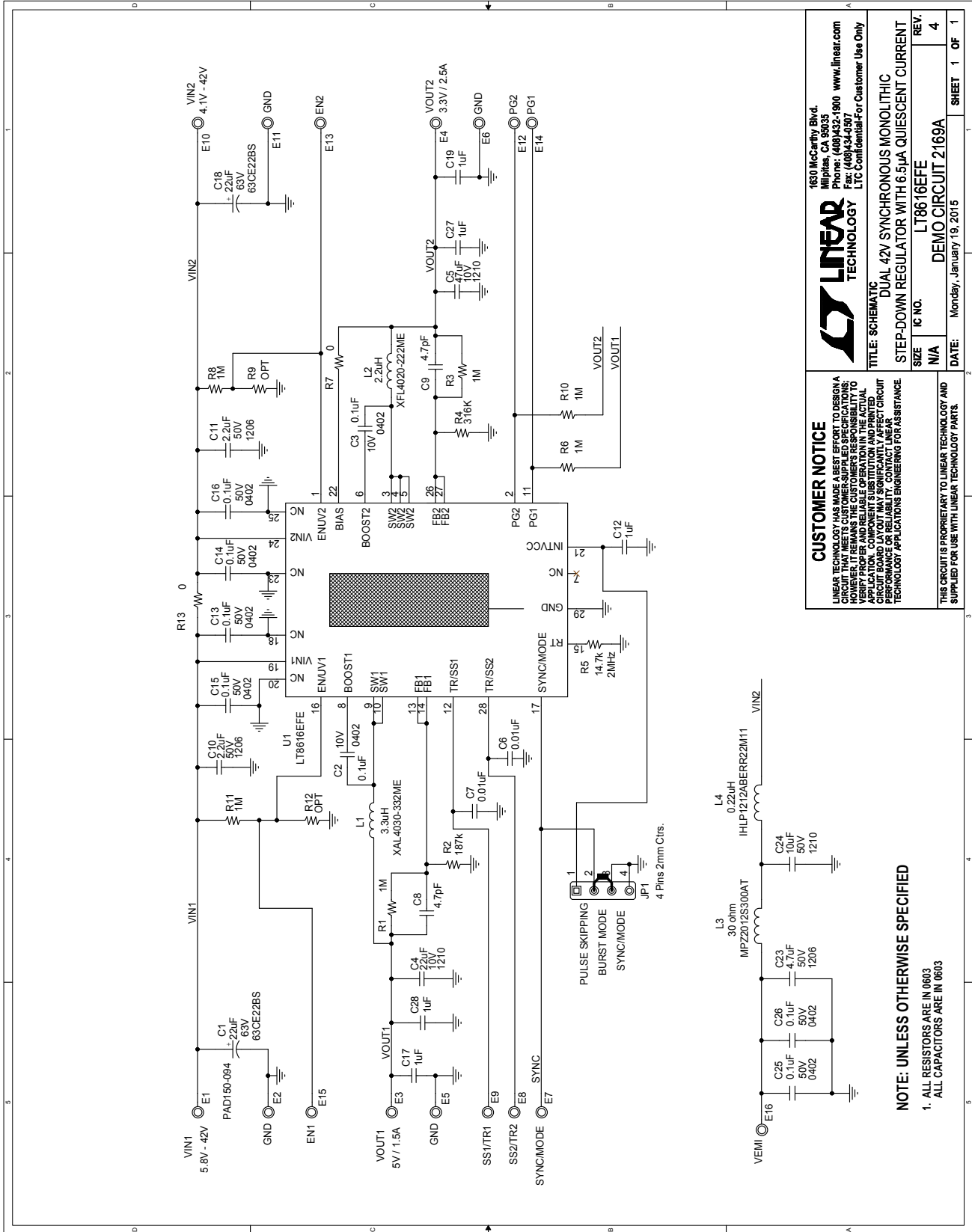

CUSTOMER NOTICE
 LINEAR TECHNOLOGY HAS MADE A BEST EFFORT TO DESIGN A CIRCUIT THAT MEETS CUSTOMER-SUPPLIED SPECIFICATIONS. HOWEVER, IT REMAINS THE CUSTOMER'S RESPONSIBILITY TO VERIFY THAT THE CIRCUIT MEETS THE SPECIFICATIONS FOR THE APPLICATION AND RELIABILITY CRITERIA AND THAT THE ACTUAL CIRCUIT BOARD LAYOUT MAY SIGNIFICANTLY AFFECT CIRCUIT PERFORMANCE OR RELIABILITY. CONTACT LINEAR TECHNOLOGY APPLICATIONS ENGINEERING FOR ASSISTANCE.

LINEAR TECHNOLOGY
 1630 McCarthy Blvd.
 Milpitas, CA 95035-5000 www.linear.com
 Phone: 408/255-3000
 Fax: 408/255-4597
 LTC Confidential-For Customer Use Only

TITLE: SCHEMATIC
DUAL 42V SYNCHRONOUS MONOLITHIC
STEP-DOWN REGULATOR WITH 6.5µA QUIESCENT CURRENT

SIZE N/A
REV. 4
IC NO. LT8616EFE
DATE: Monday, January 19, 2015
DEMO CIRCUIT 2169A

THIS CIRCUIT IS PROPRIETARY TO LINEAR TECHNOLOGY AND SUPPLIED FOR USE WITH LINEAR TECHNOLOGY PARTS.

SHEET 1 OF 1

NOTE: UNLESS OTHERWISE SPECIFIED
 1. ALL RESISTORS ARE IN 0603
 ALL CAPACITORS ARE IN 0603



Information furnished by Linear Technology Corporation is believed to be accurate and reliable. However, no responsibility is assumed for its use. Linear Technology Corporation makes no representation that the interconnection of its circuits as described herein will not infringe on existing patent rights.

DEMO MANUAL DC2169A

DEMONSTRATION BOARD IMPORTANT NOTICE

Linear Technology Corporation (LTC) provides the enclosed product(s) under the following **AS IS** conditions:

This demonstration board (DEMO BOARD) kit being sold or provided by Linear Technology is intended for use for **ENGINEERING DEVELOPMENT OR EVALUATION PURPOSES ONLY** and is not provided by LTC for commercial use. As such, the DEMO BOARD herein may not be complete in terms of required design-, marketing-, and/or manufacturing-related protective considerations, including but not limited to product safety measures typically found in finished commercial goods. As a prototype, this product does not fall within the scope of the European Union directive on electromagnetic compatibility and therefore may or may not meet the technical requirements of the directive, or other regulations.

If this evaluation kit does not meet the specifications recited in the DEMO BOARD manual the kit may be returned within 30 days from the date of delivery for a full refund. **THE FOREGOING WARRANTY IS THE EXCLUSIVE WARRANTY MADE BY THE SELLER TO BUYER AND IS IN LIEU OF ALL OTHER WARRANTIES, EXPRESSED, IMPLIED, OR STATUTORY, INCLUDING ANY WARRANTY OF MERCHANTABILITY OR FITNESS FOR ANY PARTICULAR PURPOSE. EXCEPT TO THE EXTENT OF THIS INDEMNITY, NEITHER PARTY SHALL BE LIABLE TO THE OTHER FOR ANY INDIRECT, SPECIAL, INCIDENTAL, OR CONSEQUENTIAL DAMAGES.**

The user assumes all responsibility and liability for proper and safe handling of the goods. Further, the user releases LTC from all claims arising from the handling or use of the goods. Due to the open construction of the product, it is the user's responsibility to take any and all appropriate precautions with regard to electrostatic discharge. Also be aware that the products herein may not be regulatory compliant or agency certified (FCC, UL, CE, etc.).

No License is granted under any patent right or other intellectual property whatsoever. **LTC assumes no liability for applications assistance, customer product design, software performance, or infringement of patents or any other intellectual property rights of any kind.**

LTC currently services a variety of customers for products around the world, and therefore this transaction **is not exclusive**.

Please read the DEMO BOARD manual prior to handling the product. Persons handling this product must have electronics training and observe good laboratory practice standards. **Common sense is encouraged.**

This notice contains important safety information about temperatures and voltages. For further safety concerns, please contact a LTC application engineer.

Mailing Address:

Linear Technology
1630 McCarthy Blvd.
Milpitas, CA 95035

Copyright © 2004, Linear Technology Corporation

X-ON Electronics

Largest Supplier of Electrical and Electronic Components

Click to view similar products for [Power Management IC Development Tools](#) category:

Click to view products by [Analog Devices](#) manufacturer:

Other Similar products are found below :

[EVAL-ADM1168LQEBZ](#) [EVB-EP5348UI](#) [MIC23451-AAAYFL EV](#) [MIC5281YMME EV](#) [DA9063-EVAL](#) [ADP122-3.3-EVALZ](#) [ADP130-0.8-EVALZ](#) [ADP130-1.2-EVALZ](#) [ADP130-1.5-EVALZ](#) [ADP130-1.8-EVALZ](#) [ADP1714-3.3-EVALZ](#) [ADP1716-2.5-EVALZ](#) [ADP1740-1.5-EVALZ](#) [ADP1752-1.5-EVALZ](#) [ADP1828LC-EVALZ](#) [ADP1870-0.3-EVALZ](#) [ADP1871-0.6-EVALZ](#) [ADP1873-0.6-EVALZ](#) [ADP1874-0.3-EVALZ](#) [ADP1882-1.0-EVALZ](#) [ADP199CB-EVALZ](#) [ADP2102-1.25-EVALZ](#) [ADP2102-1.875EVALZ](#) [ADP2102-1.8-EVALZ](#) [ADP2102-2-EVALZ](#) [ADP2102-3-EVALZ](#) [ADP2102-4-EVALZ](#) [ADP2106-1.8-EVALZ](#) [ADP2147CB-110EVALZ](#) [AS3606-DB](#) [BQ24010EVM](#) [BQ24075TEVM](#) [BQ24155EVM](#) [BQ24157EVM-697](#) [BQ24160EVM-742](#) [BQ24296MEVM-655](#) [BQ25010EVM](#) [BQ3055EVM](#) [NCV891330PD50GEVB](#) [ISLUSBI2CKIT1Z](#) [LM2744EVAL](#) [LM2854EVAL](#) [LM3658SD-AEV/NOPB](#) [LM3658SDEV/NOPB](#) [LM3691TL-1.8EV/NOPB](#) [LM4510SDEV/NOPB](#) [LM5033SD-EVAL](#) [LP38512TS-1.8EV](#) [EVAL-ADM1186-1MBZ](#) [EVAL-ADM1186-2MBZ](#)