

LTC3371EFE

4-Channel 8A Configurable Buck DC/DCs with Watchdog and Power-On Reset

DESCRIPTION

Demonstration circuit 2182A is a 4-output power supply with a watchdog timer and power-on reset featuring the [LTC®3371](#). The LTC3371 has four synchronous current mode buck regulators which can be configured to share eight individual 1A power stages to create one of eight combinations of 1A, 2A, 3A and 4A regulators. The DC2182A is set up as four 2A buck regulators but can be modified to one of the other seven configurations.

The input range of the LTC3371 is ideal for single cell Li-Ion/Polymer battery applications. The buck regulators are enabled via external precision threshold enable pins to allow hardwired power up sequences.

The LTC3371 has a default operating frequency of 2MHz but can be set between 1MHz to 3MHz using an external resistor. The LTC3371 also has a PLL/MODE pin which allows the internal oscillator to synchronize to an external clock from 1MHz to 3MHz or configure the regulators to forced continuous mode or burst mode.

Refer to the LTC3371 data sheet for more details on the electrical and timing specifications.

Design files for this circuit board are available at <http://www.linear.com/demo/DC2182A>.

LT, LTC, LTM, Linear Technology and the Linear logo are registered trademarks of Linear Technology Corporation. All other trademarks are the property of their respective owners.

PERFORMANCE SUMMARY

Specifications are at $T_A = 25^\circ\text{C}$

PARAMETER	CONDITIONS	MIN	TYP	MAX	UNITS
Input Supply Range (V_{INA-H})		2.25		5.5	V
VCC Operating Voltage		2.7		5.5	V
V_{OUT1}	0 to 2A		1.2		V
V_{OUT2}	0 to 2A, $V_{INCD} > 2.5\text{V}$		2.5		V
V_{OUT3}	0 to 2A		1.8		V
V_{OUT4}	0 to 2A, $V_{INGH} > 3.3\text{V}$		3.3		V

BOARD PHOTO

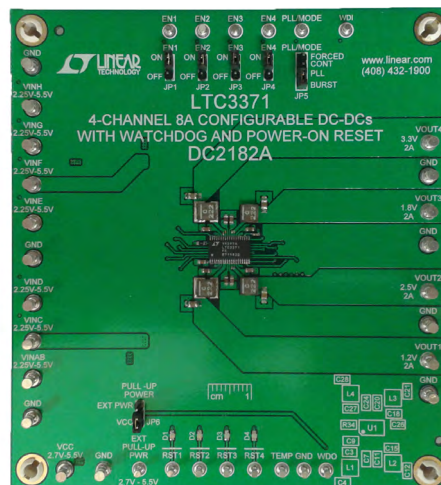

dc2182af

DEMO MANUAL DC2182A

TYPICAL APPLICATION

4 × 2A Quad Buck Application

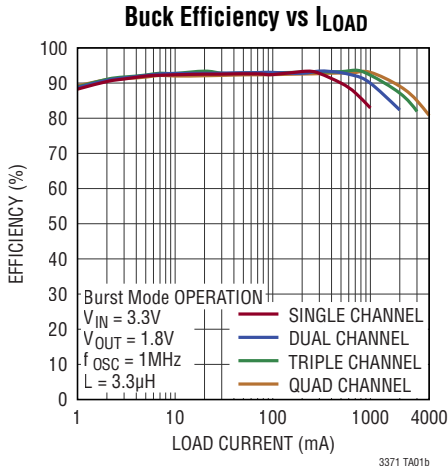
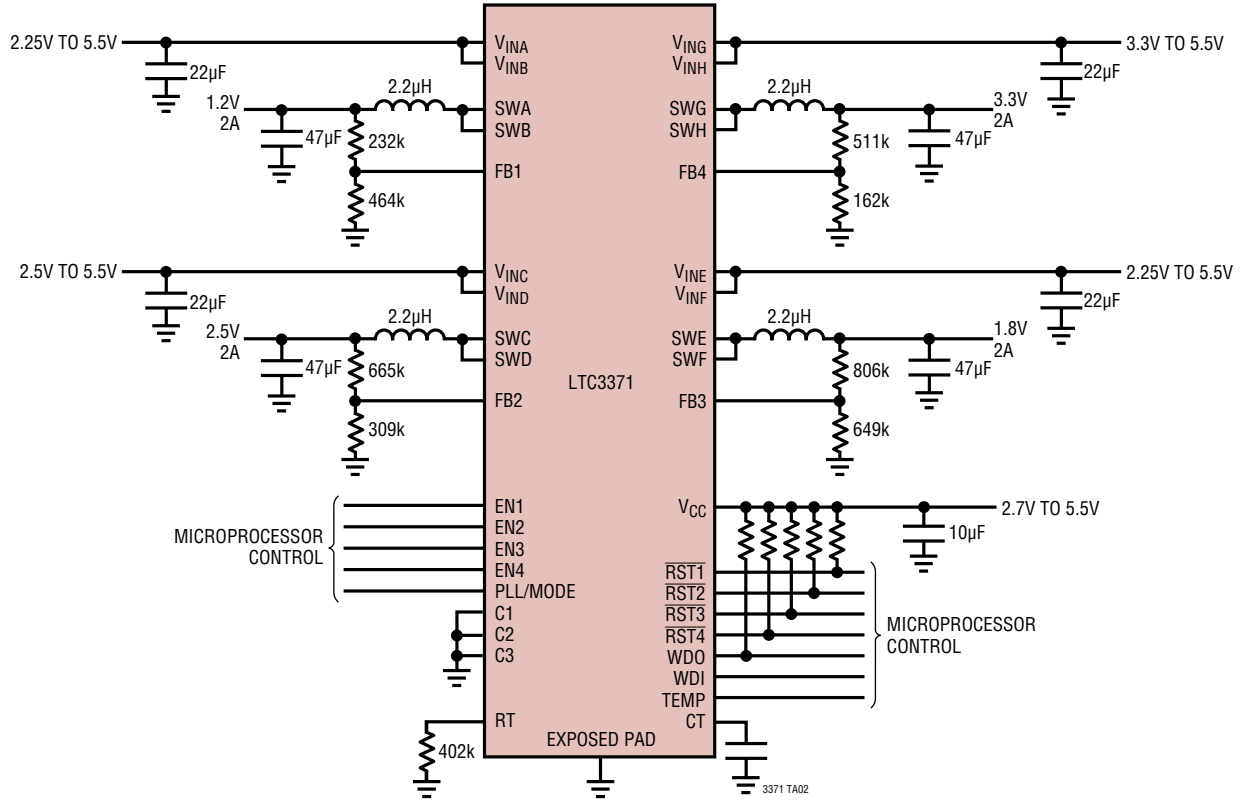

C3	C2	C1	BUCK1	BUCK2	BUCK3	BUCK4
0	0	0	2A	2A	2A	2A
0	0	1	3A	1A	2A	2A
0	1	0	3A	1A	1A	3A
0	1	1	4A	1A	1A	2A
1	0	0	3A	2A	-	3A
1	0	1	4A	-	2A	2A
1	1	0	4A	-	1A	3A
1	1	1	4A	-	-	4A

QUICK START PROCEDURE

The DC2182A is easy to set up to evaluate the performance of the LTC3371. Refer to Figure 1 and Figure 2 for proper measurement equipment setup and follow the evaluation procedure below.

NOTE. When measuring the input or output voltage ripple, care must be taken to avoid a long ground lead on the oscilloscope probe. Measure the input or output voltage ripple by touching the probe tip directly across the V_{IN} or V_{OUT} and GND terminals. See Figure 2 for proper scope probe technique.

1. Set the JP1 – JP4 jumpers on the DC2182A board to the ON position.
2. Set the JP5 jumper on the DC2182A board to the BURST position.
3. Set the JP6 jumper on the DC2182A board to the V_{CC} position.
4. With power off, connect a 0V to 6V, 50mA power supply (PS5) to V_{CC} input terminal and GND with a series ammeter and a voltmeter as shown in 0.
5. Turn on and set the PS5 to a desired input voltage between 2.7V and 5.5V.
6. With a digital volt meter, measure the voltage on the temp pin. This represents the die temperature, $(V_{TEMP} - 45mV)/7mV = ^\circ C$. $220mV = 25^\circ C$
7. With power off, connect 0V to 6V, 3A power supplies to each input pair (PS1-PS4), V_{INAB} , V_{INC}/V_{IND} , V_{INE}/V_{INF} , V_{ING}/V_{INH} and GND with a series ammeter and a voltmeter as shown in Figure 1. A single 0V to 6V, 10A supply can be used instead to supply all V_{IN} inputs and the V_{CC} input simultaneously.
8. Turn on and set the PS1 input power supply to 5.0V and observe that V_{OUT1} regulates to 1.2V.
NOTE. Make sure that the input voltage does not exceed 6V.
9. With power off, connect a 0A to 2A load to V_{OUT1} and GND with a series ammeter and a voltmeter as shown in Figure 1.
10. Slowly increase the load from 0A to 2A and observe the output voltage. The output ripple may also be observed using an oscilloscope with the probe connected as shown in Figure 2.
11. Set Load1 to 100mA
12. Repeat steps 8 to 11 for each output using their respective power supplies and loads. Each output voltage should regulate to the voltage indicated on the silkscreen of the DC2182A.
13. Momentarily short V_{OUT1} to ground with a clip lead and observe that the RST LED, D13, on the demo board illuminates. The LED shuts off when the short is removed.
14. With Load1 set to 100mA, observe the burst mode ripple on V_{OUT1} .
15. Set the JP5 jumper on the DC2182A board to the FORCED CONT position and observe the forced continuous mode ripple on V_{OUT1} .
16. Set an oscilloscope with two probes each to 1V/Div vertical scale and 1 μ s/Div horizontal scale. With the oscilloscope, compare the phase between SWAB to SWCD, SWEF, and then SWGH. Observe that the switch nodes are 90°, 270°, and 180° out of phase respectively with SWAB.
17. Set a pulse generator to output a 0V to 5V pulse at 2MHz, 50% duty cycle and connect it to the PLL/MODE terminal and GND.
18. Set the JP5 jumper on the DC2182A board to the PLL position.
19. Change the frequency of the pulse generator from 2MHz to 3MHz and observe how the frequency of SWAB follows the pulse generator.
20. Set LOAD1 greater than 1.0A. With an oscilloscope probe on SWAB, remove the pulse signal to the PLL/MODE terminal and observe how the switch frequency settles from 3MHz back to 2MHz.
21. Return Load1 to 100mA.
22. Set an oscilloscope with a horizontal scale of 2s/Div and the trigger set to normal acquisition, falling edge at 2V on the WDO terminal.
23. Observe that a low going pulse about 200ms wide occurs on the WDO output about every 12.9s.

QUICK START PROCEDURE

24. Set a pulse generator to output a 0V to 5V pulse at 50Hz with a 50% duty cycle and connect between the WDI and GND terminals. Observe with the oscilloscope set to 20ms/Div that pulse on WDO returns low until the next falling edge on WDI. The pulse generator is operating below the watchdog lower boundary.
25. Decrease the pulse generator frequency below 15Hz and observe that WDO remains high. The pulse generator is operating within the watchdog upper and lower boundaries.
26. Continue to decrease the frequency to below 0.5Hz and observe that WDO has a periodic 200ms low pulse.
27. Refer to the LTC3371 data sheet for more details on how the LTC3371 operates.
28. When done, turn off all loads and power supplies.

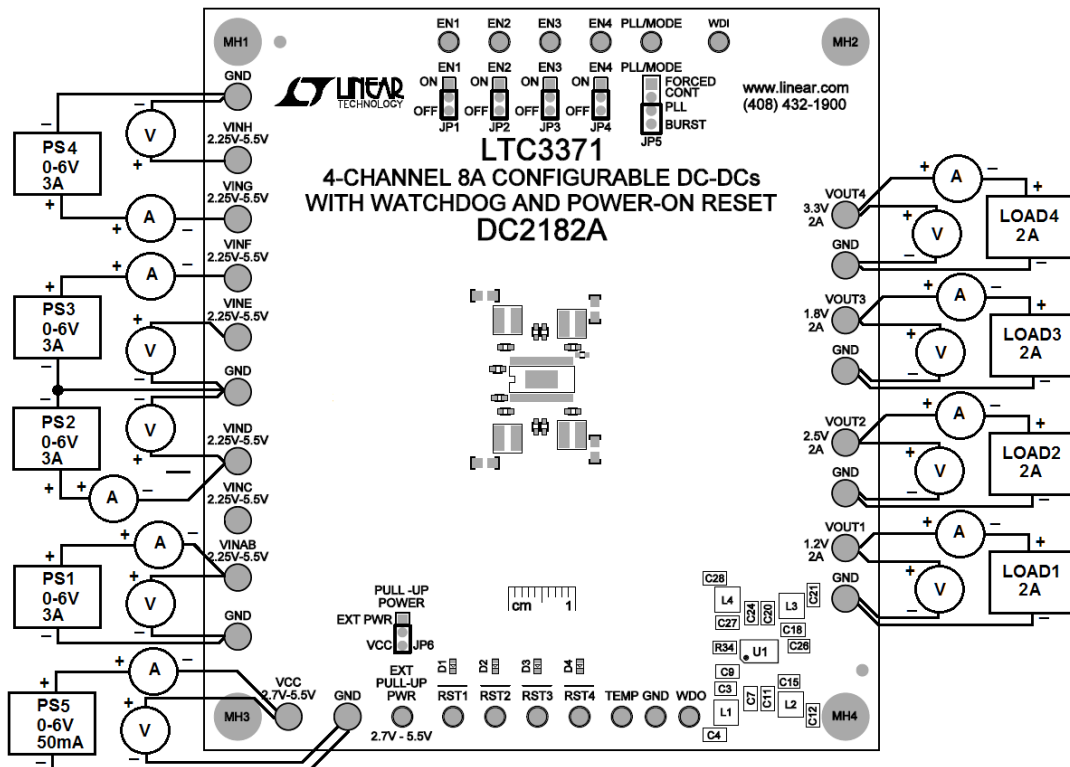

Figure 1. Proper Measurement Equipment Setup

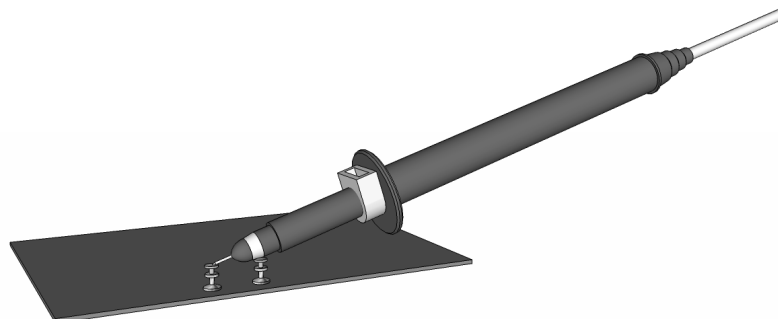

Figure 2. Measuring Input or Output Ripple

MODIFYING THE DC2182A TO OTHER POWER CONFIGURATIONS

The LTC3371 can be configured to one of eight different power configurations as shown in Table 1. To reconfigure the DC2182A to a different configuration some resistors will need to be changed, traces will need to be shorted together, and often traces will need to be cut. Follow the steps below to modify the board to a desired configuration.

1. Choose the desired configuration from Table 1.

Table 1. Master Slave Program Combinations (Each Letter Corresponds to a V_{IN} and SW Pair)

PROGRAM CODE C3C2C1	BUCK 1	BUCK 2	BUCK 3	BUCK 4
000	AB	CD	EF	GH
001	ABC	D	EF	GH
010	ABC	D	E	FGH
011	ABCH	D	E	FG
100	ABC	DE	Not Used	FGH
101	ABCD	Not Used	EF	GH
110	ABCD	Not Used	E	FGH
111	ABCD	Not Used	Not Used	EFGH

2. Set the associated C bit pins high or low as per Table 1 by opening and populating the appropriate resistors. C1, C2 and C3 are set high by populating R7, R11 and R14 respectively. C1, C2 and C3 are set low by populating R9, R13 and R16 respectively. The C bit resistors are 0603 resistors located on the bottom of the board as shown in Figure 3.

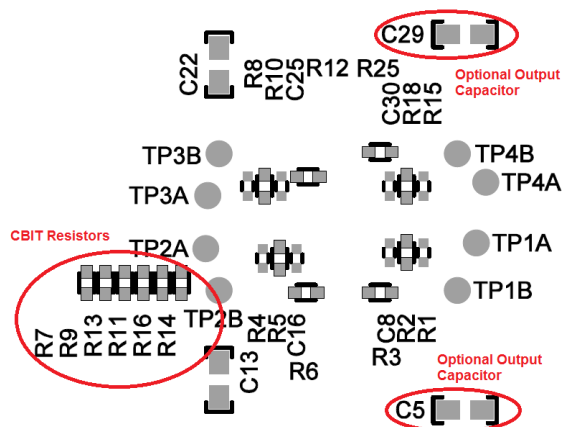

Figure 3. C Bit Resistors and Optional Output Capacitors for V_{OUT1} and V_{OUT4}

3. The DC2182A is set up with the following power stage switch nodes and V_{IN} nodes connected together; A & B, C & D, E & F, and G & H. Any configuration using 1A or 3A regulators will require one or more of the V_{IN} and switch nodes to be separated. Refer to Table 1 to determine which power stages are connected together and separated. Cut the required V_{IN} nodes by cutting the V_{IN} traces on the bottom of the board near the V_{IN} terminals as shown in Figure 4.

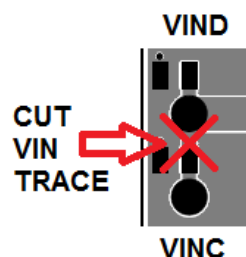

Figure 4. Separate V_{IN} Pairs by Cutting Traces at Terminals

MODIFYING THE DC2182A TO OTHER POWER CONFIGURATIONS

4. Any switch node associated with a V_{IN} trace that was cut will also need to be cut. The SWC/SWD traces and SWD/SWF traces can be cut in between the pads near the SW pins as shown in Figure 5. The SWG/SWH traces only need to be cut for the 4112 configuration. SWH needs to be cut between the SWH pin and L4 as shown in Figure 6.

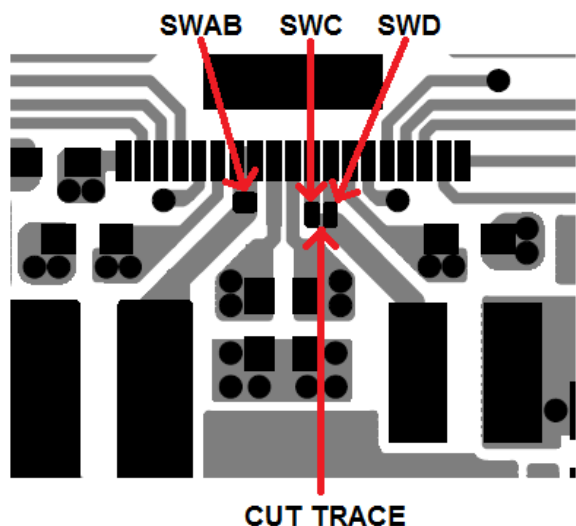

Figure 5. Cut SWC and SWD Connection Near Pins

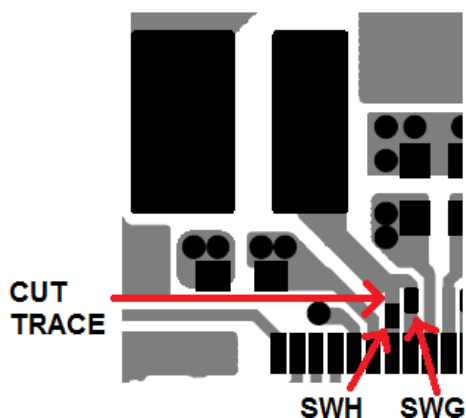

Figure 6. Cut SWH Trace Between L4 and SWH Pin

5. For all combinations containing 3A and 4A outputs, the V_{IN} nodes of adjoining power stages will need to be connected together. Connect all V_{IN} nodes of adjoining power stages at the V_{IN} terminals with a 22AWG wire or larger.

6. All switch nodes of adjoining power stages will need to be connected together. Each power stage has a pad to solder a small bus wire, 28AWG. The switch node pads are also shown in Figure 5 and Figure 6. Carefully solder a bus wire as short as possible between adjoining power stages.

NOTE: For the 4112 combination, switch AB will need to connect to switch C and switch H. For the 332 combination, switch D will need to connect to switch E.

7. The XAL4020-222M inductors are rated for 5.5A. This is less than the current limit of the 3A or 4A regulators. The pads for L1 and L4 are sized to accommodate a 5mm × 5mm inductor such as the Toko FSD05xx or the Coilcraft XAL05xx series. Change inductors L1 and/or L4 to accommodate current limit conditions if needed.

8. Remove the inductors of any unused regulators as illustrated in Table 1.

9. The output capacitance requires a minimum of 22μF for each 1A of output current. Each output has an optional 0805 capacitor on the bottom of the board. Add the required amount of capacitance to C5 and/or C29 (shown in Figure 3) for V_{OUT1} and V_{OUT4} respectively, if needed.

10. Set the enable jumpers of any unused regulators in Table 1 to the "off" position.

APPLICATION INFORMATION

The DC2182A can be used to evaluate each of the eight configurations of the LTC3371 from 1MHz to 3MHz. The following efficiency graphs and transient response plots

illustrate how a 1.8V, 1A regulator performs compared to a 1.8V, 4A regulator. Please refer to the LTC3371 data sheet for more performance information for the LTC3371.

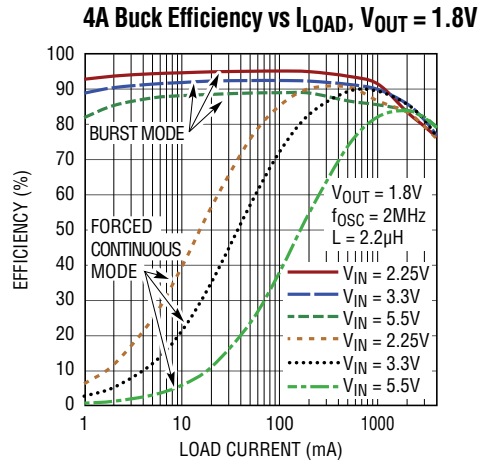
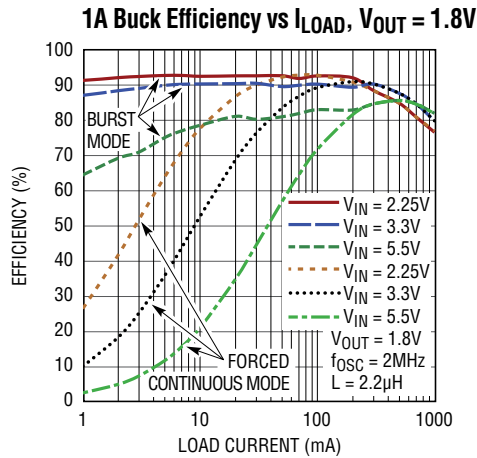

1A Buck Regulator, Transient Response (Burst Mode Operation)

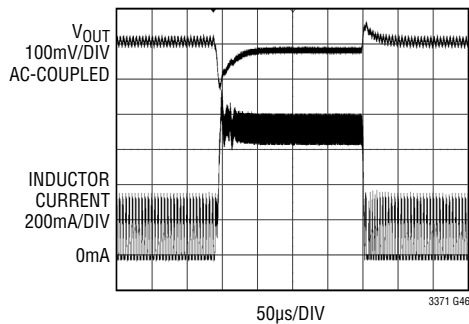

LOAD STEP = 100mA TO 700mA
 $V_{IN} = 3.3V$
 $V_{OUT} = 1.8V$

1A Buck Regulator, Transient Response (Forced Continuous Mode)

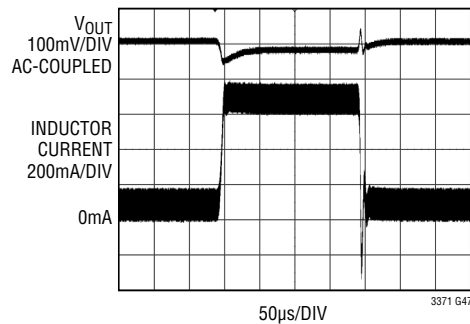

LOAD STEP = 100mA TO 700mA
 $V_{IN} = 3.3V$
 $V_{OUT} = 1.8V$

4A Buck Regulator, Transient Response (Burst Mode Operation)

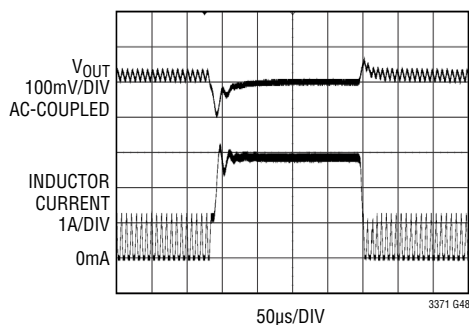

LOAD STEP = 400mA TO 2.8A
 $V_{IN} = 3.3V$
 $V_{OUT} = 1.8V$

4A Buck Regulator, Transient Response (Forced Continuous Mode)

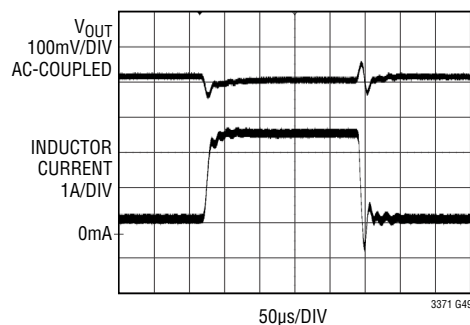

LOAD STEP = 400mA TO 2.8A
 $V_{IN} = 3.3V$
 $V_{OUT} = 1.8V$

DEMO MANUAL DC2182A

PARTS LIST

ITEM	QTY	REFERENCE	PART DESCRIPTION	MANUFACTURER/PART NUMBER
Required Circuit Components				
1	1	C1	CAP, CHIP, X5R, 22 μ F, \pm 20%, 6.3V, 0805	TAIYO YUDEN, JMK212ABJ226MG-T
3	9	C3, C7, C9, C11, C15, C18, C20, C24, C27	CAP, CHIP, X5R, 10 μ F, \pm 20%, 6.3V, 0603	TDK, C1608X5R0J106M
4	4	C4, C12, C21, C28	CAP, CHIP, X5R, 47 μ F, \pm 20%, 6.3V, 0805	MURATA, GRM21BR60J476ME15L
7	4	C8, C16, C25, C30	CAP, CHIP, NPO, 10pF, \pm 5%, 50V, 0402	MURATA, GRM1555C1H100JA01D
8	1	C26	CAP, CHIP, X7R, 0.01 μ F, \pm 10%, 25V, 0402	MURATA, GRM155R71E103KA01D
15	4	L1-L4	IND, SMT, 2.2 μ H, 38m Ω , \pm 20%, 5.5A, 4mmX4mm	COILCRAFT, XAL4020-222MEC
17	2	R2	RES, CHIP, 232K Ω , \pm 1%, 1/10W, 0603	VISHAY, CRCW0603232KFKEA
18	1	R3	RES, CHIP, 464K Ω , \pm 1%, 1/10W, 0603	VISHAY, CRCW0603464KFKEA
19	1	R5	RES, CHIP, 665k Ω , \pm 1%, 1/10W, 0603	VISHAY, CRCW0603665KFKEA
20	1	R6	RES, CHIP, 309K Ω , \pm 1%, 1/10W, 0603	VISHAY, CRCW0603309KFKEA
23	1	R10	RES, CHIP, 806K Ω , \pm 1%, 1/10W, 0603	VISHAY, CRCW0603806KFKEA
24	1	R12	RES, CHIP, 649K Ω , \pm 1%, 1/10W, 0603	VISHAY, CRCW0603649KFKEA
26	1	R18	RES, CHIP, 511K Ω , \pm 1%, 1/10W, 0603	VISHAY, CRCW0603511KFKEA
28	1	R25	RES, CHIP, 162K Ω , \pm 1%, 1/10W, 0603	VISHAY, CRCW0603162KFKEA
29	1	R34	RES, CHIP, 402K Ω , \pm 1%, 1/10W, 0603	VISHAY, CRCW0603402KFKEA
30	1	U1	4-CHANNEL 8A CONFIGURABLE BUCK DC-DCs, TSSOP	LINEAR TECH., LTC3371EFE
Additional Demo Board Circuit Components				
2	1	C2	CAP, POSCAP, 100 μ F, \pm 20%, 6.3V, SMT	PANASONIC, 6TPG100MG
5	0	C5, C13, C22, C29 (OPT)	CAP, CHIP, 0805	
6	6	C6, C10, C14, C17, C19, C23	CAP, POSCAP, 47 μ F, \pm 20%, 6.3V, SMT	PANASONIC, 6TPC47M
9	4	D1-D4	DIODE, LED, SUPER RED DIFF, 0603 SMD	LUMEX, SML-LX0603SRW-TR
16	4	R1, R4, R8, R15	RES, CHIP, 20 Ω , \pm 1%, 1/16W, 0402	VISHAY, CRCW040220R0FKED
21	0	R7, R11, R14 (OPT)	RES, CHIP, 1/10W, 0603	
22	3	R9, R13, R16	RES, CHIP, 0 Ω JUMPER, 1/10W, 0603	VISHAY, CRCW06030000Z0EA
25	10	R17, R20-R23, R26, R28, R30, R32, R35	RES, CHIP, 1K Ω , \pm 5%, 1/16W, 0402	VISHAY, CRCW04021K00JNED
27	7	R19, R24, R27, R29, R31, R33, R36	RES, CHIP, 1.0M Ω , \pm 5%, 1/16W, 0402	VISHAY, CRCW04021M00JNED
Hardware				
10	20	E1-E18, E32, E34	TURRET, 0.09 DIA	MILL-MAX, 2501-2-00-80-00-00-07-0
11	13	E19-E31, E33	TURRET, 0.061 DIA	MILL-MAX, 2308-2-00-80-00-00-07-0
12	5	JP1-JP4, JP6	2mm to HEADER 1X3, 2mm	SAMTEC, TMM-103-02-L-S
13	1	JP5	2mm to HEADER 1X4, 2mm	SAMTEC, TMM-104-02-L-S
14	6	JP1-JP6	SHUNT, 2mm	SAMTEC, 2SN-KB-G
31	4		STAND-OFF NYLON, 0.375" TALL (SNAP-ON)	KEYSTONE, 8832 (SNAP ON)

SCHEMATIC DIAGRAM

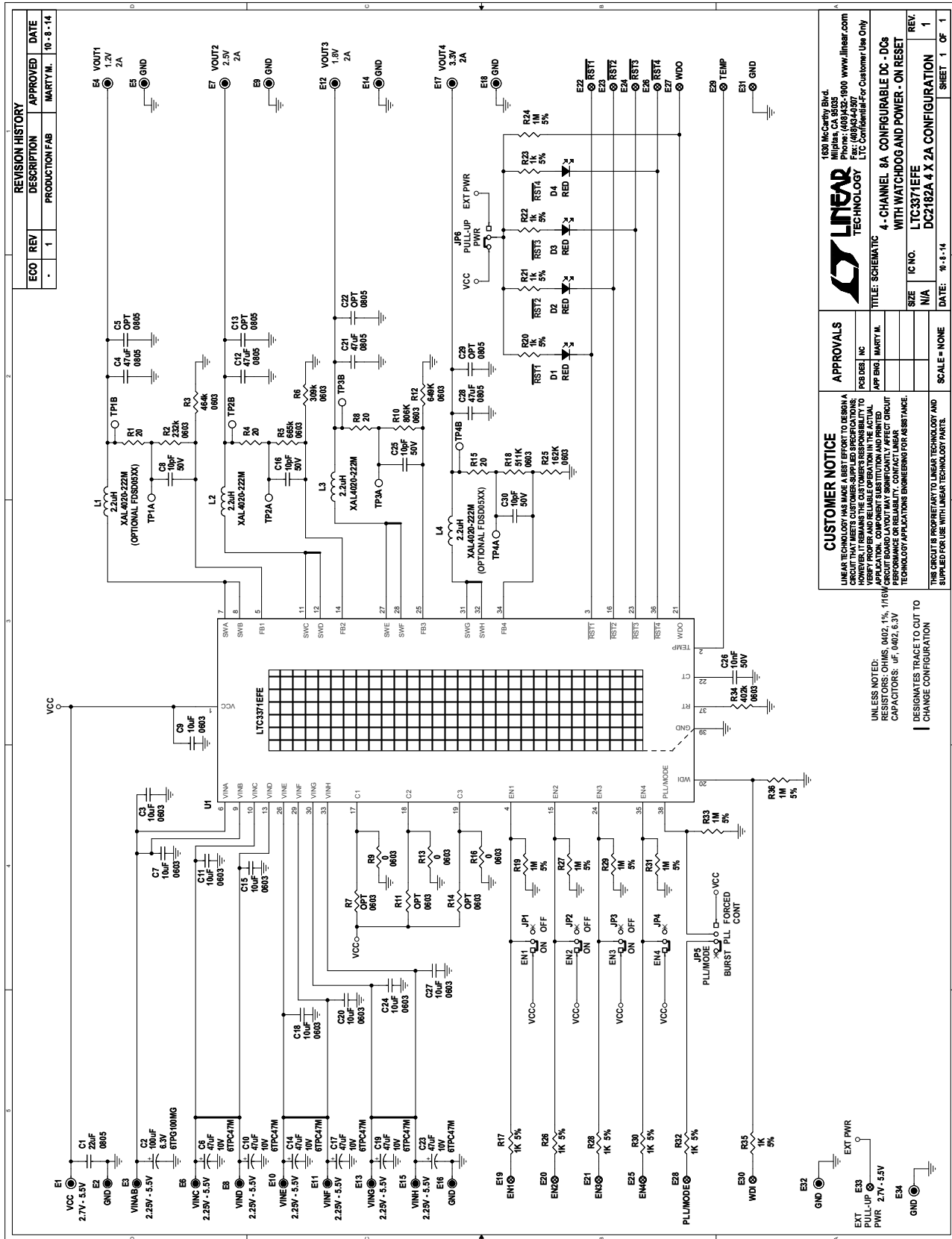

REVISION HISTORY			
ECO	REV	DESCRIPTION	DATE
-	1	PRODUCTION FAB	10-8-14

1630 McCarty Blvd. Fremont, CA 94538 Tel: (925) 462-0000 www.linear.com Fax: (925) 462-1000	
TITLE: SCHEMATIC 4-CHANNEL 8A CONFIGURABLE DC-DCs WITH WATCHDOG AND POWER - ON RESET	
SIZE	IC NO.
N/A	LTC3371EFE
DATE	DATE
10-8-14	10-8-14
SHEET 1	OF 1

CUSTOMER NOTICE
 LINEAR TECHNOLOGY HAS MADE A BEST EFFORT TO DESIGN A CIRCUIT THAT MEETS CUSTOMER-SUPPLIED SPECIFICATIONS; HOWEVER, IT REMAINS THE CUSTOMER'S RESPONSIBILITY TO VERIFY THE PERFORMANCE OF THE CIRCUIT IN ALL APPLICATIONS. COMPONENT SUBSTITUTION AND PRINTED CIRCUIT BOARD LAYOUT MAY SIGNIFICANTLY AFFECT CIRCUIT PERFORMANCE OR RELIABILITY. CONTACT LINEAR TECHNOLOGY APPLICATIONS ENGINEERING FOR ASSISTANCE.

APPROVALS
 PCB DES: INC
 APP ENG: MARTY M.
 SCALE = NONE

UNLESS NOTED:
 RESISTORS: OHMS, 0402, 1%, 110V
 CAPACITORS: μ F, 0402, 6.3V
 DESIGNATES TRACE TO, CUT TO CHANGE CONFIGURATION

Figure 7. DC2182A Demo Circuit Schematic

DEMO MANUAL DC2182A

DEMONSTRATION BOARD IMPORTANT NOTICE

Linear Technology Corporation (LTC) provides the enclosed product(s) under the following **AS IS** conditions:

This demonstration board (DEMO BOARD) kit being sold or provided by Linear Technology is intended for use for **ENGINEERING DEVELOPMENT OR EVALUATION PURPOSES ONLY** and is not provided by LTC for commercial use. As such, the DEMO BOARD herein may not be complete in terms of required design-, marketing-, and/or manufacturing-related protective considerations, including but not limited to product safety measures typically found in finished commercial goods. As a prototype, this product does not fall within the scope of the European Union directive on electromagnetic compatibility and therefore may or may not meet the technical requirements of the directive, or other regulations.

If this evaluation kit does not meet the specifications recited in the DEMO BOARD manual the kit may be returned within 30 days from the date of delivery for a full refund. **THE FOREGOING WARRANTY IS THE EXCLUSIVE WARRANTY MADE BY THE SELLER TO BUYER AND IS IN LIEU OF ALL OTHER WARRANTIES, EXPRESSED, IMPLIED, OR STATUTORY, INCLUDING ANY WARRANTY OF MERCHANTABILITY OR FITNESS FOR ANY PARTICULAR PURPOSE. EXCEPT TO THE EXTENT OF THIS INDEMNITY, NEITHER PARTY SHALL BE LIABLE TO THE OTHER FOR ANY INDIRECT, SPECIAL, INCIDENTAL, OR CONSEQUENTIAL DAMAGES.**

The user assumes all responsibility and liability for proper and safe handling of the goods. Further, the user releases LTC from all claims arising from the handling or use of the goods. Due to the open construction of the product, it is the user's responsibility to take any and all appropriate precautions with regard to electrostatic discharge. Also be aware that the products herein may not be regulatory compliant or agency certified (FCC, UL, CE, etc.).

No License is granted under any patent right or other intellectual property whatsoever. **LTC assumes no liability for applications assistance, customer product design, software performance, or infringement of patents or any other intellectual property rights of any kind.**

LTC currently services a variety of customers for products around the world, and therefore this transaction **is not exclusive**.

Please read the DEMO BOARD manual prior to handling the product. Persons handling this product must have electronics training and observe good laboratory practice standards. **Common sense is encouraged.**

This notice contains important safety information about temperatures and voltages. For further safety concerns, please contact a LTC application engineer.

Mailing Address:

Linear Technology
1630 McCarthy Blvd.
Milpitas, CA 95035

Copyright © 2004, Linear Technology Corporation

X-ON Electronics

Largest Supplier of Electrical and Electronic Components

Click to view similar products for [Power Management IC Development Tools](#) category:

Click to view products by [Analog Devices](#) manufacturer:

Other Similar products are found below :

[EVAL-ADM1168LQEBZ](#) [EVB-EP5348UI](#) [MIC23451-AAAYFL EV](#) [MIC5281YMME EV](#) [DA9063-EVAL](#) [ADP122-3.3-EVALZ](#) [ADP130-0.8-EVALZ](#) [ADP130-1.2-EVALZ](#) [ADP130-1.5-EVALZ](#) [ADP130-1.8-EVALZ](#) [ADP1714-3.3-EVALZ](#) [ADP1716-2.5-EVALZ](#) [ADP1740-1.5-EVALZ](#) [ADP1752-1.5-EVALZ](#) [ADP1828LC-EVALZ](#) [ADP1870-0.3-EVALZ](#) [ADP1871-0.6-EVALZ](#) [ADP1873-0.6-EVALZ](#) [ADP1874-0.3-EVALZ](#) [ADP1882-1.0-EVALZ](#) [ADP199CB-EVALZ](#) [ADP2102-1.25-EVALZ](#) [ADP2102-1.875EVALZ](#) [ADP2102-1.8-EVALZ](#) [ADP2102-2-EVALZ](#) [ADP2102-3-EVALZ](#) [ADP2102-4-EVALZ](#) [ADP2106-1.8-EVALZ](#) [ADP2147CB-110EVALZ](#) [AS3606-DB](#) [BQ24010EVM](#) [BQ24075TEVM](#) [BQ24155EVM](#) [BQ24157EVM-697](#) [BQ24160EVM-742](#) [BQ24296MEVM-655](#) [BQ25010EVM](#) [BQ3055EVM](#) [NCV891330PD50GEVB](#) [ISLUSBI2CKIT1Z](#) [LM2744EVAL](#) [LM2854EVAL](#) [LM3658SD-AEV/NOPB](#) [LM3658SDEV/NOPB](#) [LM3691TL-1.8EV/NOPB](#) [LM4510SDEV/NOPB](#) [LM5033SD-EVAL](#) [LP38512TS-1.8EV](#) [EVAL-ADM1186-1MBZ](#) [EVAL-ADM1186-2MBZ](#)