

High Side Current Sense Amplifier with Reference and Comparator with POR Capability

DESCRIPTION

Demonstration circuit 2193A features the [LT[®]6118](#), a high side current sense amplifier with a comparator and a 400mV reference.

The demo board circuit amplifies the voltage across an on-board current sense resistor, to provide a precision unipolar voltage output that is proportional to the sensed current. The board has one on-board latching comparator and an integrated 400mV reference that sets the threshold for the comparator. The demonstration board includes circuitry to guarantee that the comparator resets on power up. The

current sense gain and current fault limits are set by on board resistors. The gain is 2.5V/A and the comparator is set to trip at current threshold of 500mA.

The key performance specifications are listed in the table below.

Design files for this circuit board are available at <http://www.linear.com/demo/DC2193A>

LT, LT, LTC, LTM, Linear Technology and the Linear logo are registered trademarks of Linear Technology Corporation. All other trademarks are the property of their respective owners.

PERFORMANCE SUMMARY

Specifications are at $T_A = 25^\circ\text{C}$

SYMBOL	PARAMETER	CONDITIONS	MIN	TYP	MAX	UNITS
V_{IN}	Input Supply Range		2.7		60	V
V_{IOUT}	Measured Output Signal	$I_{LOAD} = 100\text{mA}$		250		mV
I_{IOUT}	Measured Output Signal(Current Mode)	$V_{IOUT} = 250\text{mV}$		100		μA
I_{OUT}	Output Load Current Range	Thermal Limit of R_{SENSE}			4	A
I_Q	V_{IN} Quiescent Current	$V_{IN} = 12\text{V}$		800		μA
V_{THR}	Comparator Threshold	$V_{IOUT} = 1.25\text{V}$		500		mA

OPERATING PRINCIPLES

The LT6118 operates by amplifying the voltage drop across a sense resistor that is in series with the load. The sense inputs of the amplifier differentially measure the sense resistor voltage drop to control an internal variable current source that allows translation of the input voltage level to a level referenced to the GND. The circuit gain is set by the ratio of the output resistor to the input resistor. The comparator thresholds are set by the LT6118 internal

reference and the current trip points are set by dividing the output resistance into a network of three resistors. The RC filter connected to the Latch Enable (LE) pin guarantee that the LE pin is held low long enough on startup to reset the comparator output on power on. The DC2193 is shipped with a 100m Ω sense resistor. The amplifier gain is 25V/V, providing an overall circuit gain of 2.5V/A. The overcurrent fault threshold is set to 500mA.

BLOCK DIAGRAM

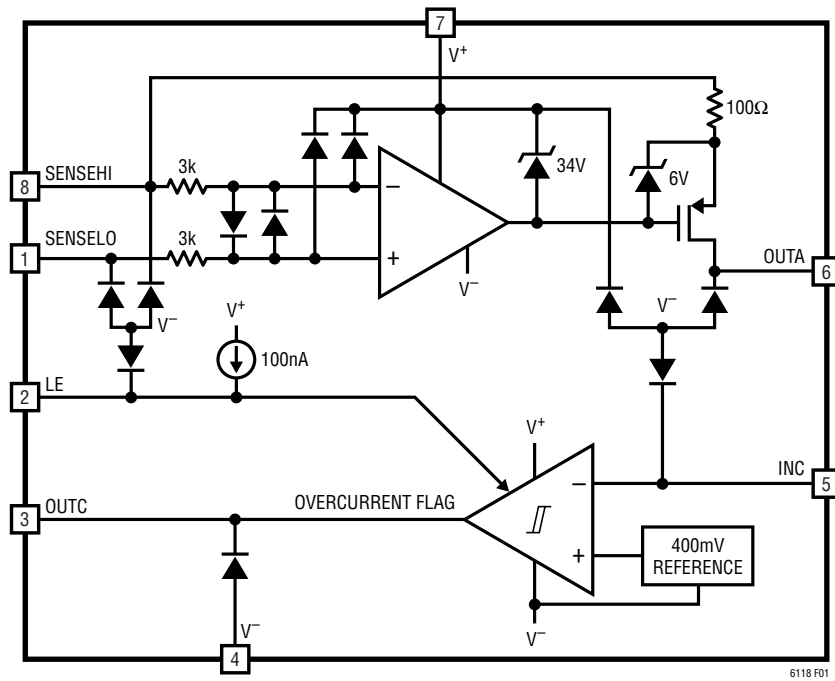

QUICK START PROCEDURE

The DC2193A provides a simple way to evaluate the performance of the LT6118. Refer to Figure 1 for proper measurement equipment setup and follow these procedures:

1. With the power off, connect the power supply positive to IN and the common to GND. With default board settings the supply can range from 2.7V to 60V. If the supply does not have an accurate current readout, a DMM may be connected in series with the supply as shown in Figure 1.
2. Connect a DMM or oscilloscope to the I_{OUT} with the common connection connected to ground.
3. Connect a load to the demo boards OUT terminal (positive) and ground. The load may be a power resistor, active load instrument or a circuit of interest.
4. Turn on the power supply. The comparator will reset during power on and will start in the correct state based on the load current. With the load shown in Figure 1 the comparator output should be at 20V
5. Measure the output voltage and confirm that it corresponds to the load current. $V_{IOUT} = 2.5 \cdot I_{LOAD(A)}$ with the provided resistors.
6. If able, sweep load current from 0mA to 500mA to verify the operation of the comparator. OUTC will latch low when I_{LOAD} exceeds 500mA.

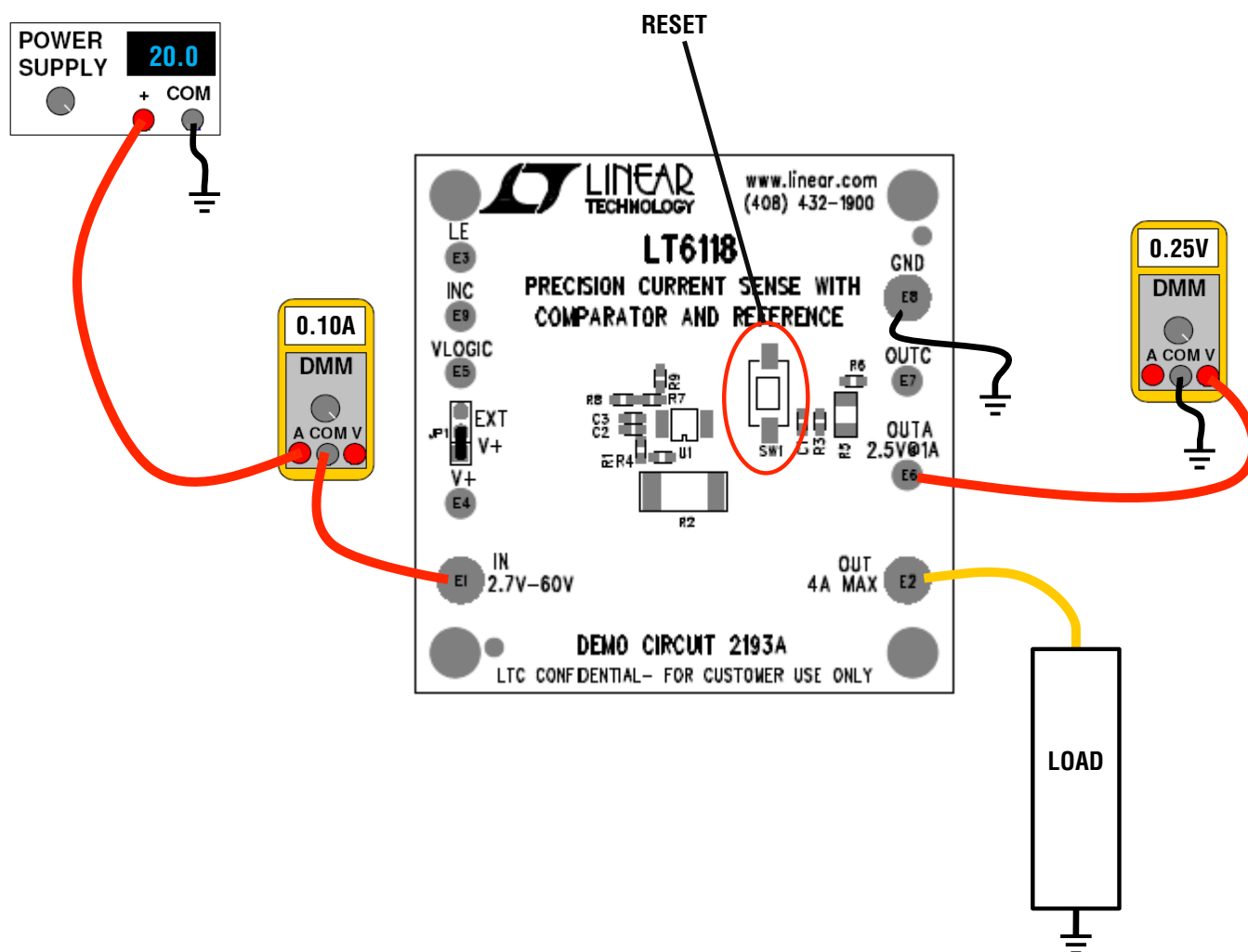

Figure 1

OPERATION

Current Sense Gain

The gain of the LT6118 current sense amplifier is set by the ratio of R_{OUT} and R_{IN} resistors. In the demo circuit this means that the gain is set by the ratio of $(R7 + R9)/R4$. The gain error is primarily controlled by the precision of the resistors used. The provided resistors are a 1% tolerance which will dominate the gain error. To reduce system gain error, the resistors can be replaced with 0.1% resistors.

Jumper Summary

JP1: The logic supply jumper has two settings:

V⁺: The comparator output is tied to the V⁺ supply

EXT: The comparator output is tied to an external supply on the V_{LOGIC} turret.

Optional Settings

1. To power the LT6118 from a supply separate from the load, remove R1 and connect the power supply to V⁺ turret.
2. There are a number of optional components that (not installed) allow the DC2193 to be tailored to a specific application:
 - A) To free comparator input INC for other use, remove R7 and R9 and install R8. Connect LE turret as required.
 - B) To add filtering to the amplifier output, install C3.

SCHEMATIC DIAGRAM

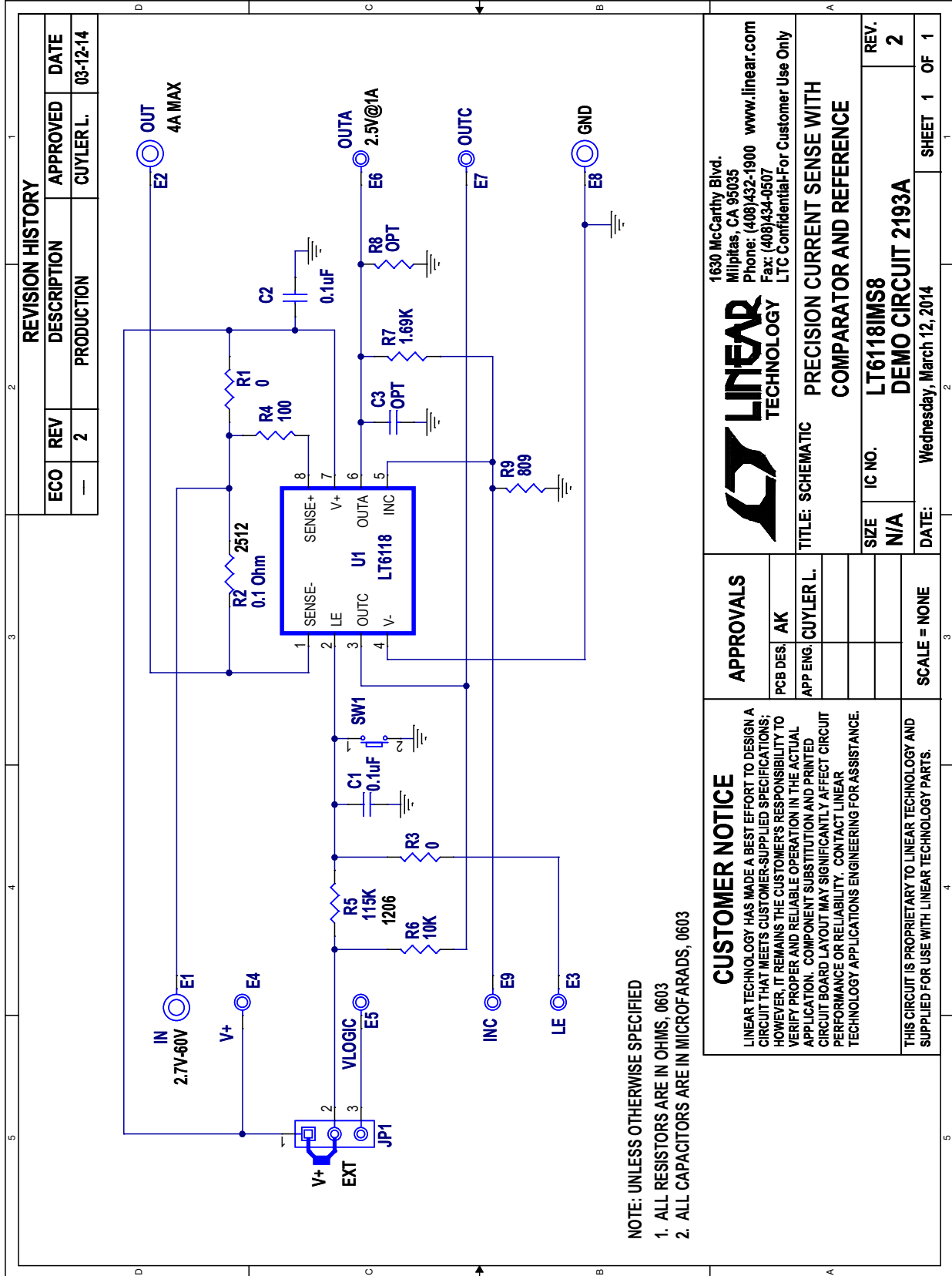

- NOTE: UNLESS OTHERWISE SPECIFIED**
1. ALL RESISTORS ARE IN OHMS, 0603
 2. ALL CAPACITORS ARE IN MICROFARADS, 0603

CUSTOMER NOTICE

LINEAR TECHNOLOGY HAS MADE A BEST EFFORT TO DESIGN A CIRCUIT THAT MEETS CUSTOMER-SUPPLIED SPECIFICATIONS; HOWEVER, IT REMAINS THE CUSTOMER'S RESPONSIBILITY TO VERIFY PROPER AND RELIABLE OPERATION IN THE ACTUAL APPLICATION. COMPONENT SUBSTITUTION AND PRINTED CIRCUIT BOARD LAYOUT MAY SIGNIFICANTLY AFFECT CIRCUIT PERFORMANCE OR RELIABILITY. CONTACT LINEAR TECHNOLOGY APPLICATIONS ENGINEERING FOR ASSISTANCE.

THIS CIRCUIT IS PROPRIETARY TO LINEAR TECHNOLOGY AND SUPPLIED FOR USE WITH LINEAR TECHNOLOGY PARTS.

APPROVALS

PCB DES.	AK
APP ENG.	CUYLER L.

SCALE = NONE



1630 McCarthy Blvd.
Milpitas, CA 95035
Phone: (408)432-1900 www.linear.com
Fax: (408)434-0507
LTC Confidential-For Customer Use Only

TITLE: SCHEMATIC		PRECISION CURRENT SENSE WITH COMPARATOR AND REFERENCE	
SIZE	IC NO.	REV.	
N/A	LT6118IMS8	2	
DATE:	Wednesday, March 12, 2014		SHEET 1 OF 1

DEMO MANUAL DC2193A

DEMONSTRATION BOARD IMPORTANT NOTICE

Linear Technology Corporation (LTC) provides the enclosed product(s) under the following **AS IS** conditions:

This demonstration board (DEMO BOARD) kit being sold or provided by Linear Technology is intended for use for **ENGINEERING DEVELOPMENT OR EVALUATION PURPOSES ONLY** and is not provided by LTC for commercial use. As such, the DEMO BOARD herein may not be complete in terms of required design-, marketing-, and/or manufacturing-related protective considerations, including but not limited to product safety measures typically found in finished commercial goods. As a prototype, this product does not fall within the scope of the European Union directive on electromagnetic compatibility and therefore may or may not meet the technical requirements of the directive, or other regulations.

If this evaluation kit does not meet the specifications recited in the DEMO BOARD manual the kit may be returned within 30 days from the date of delivery for a full refund. **THE FOREGOING WARRANTY IS THE EXCLUSIVE WARRANTY MADE BY THE SELLER TO BUYER AND IS IN LIEU OF ALL OTHER WARRANTIES, EXPRESSED, IMPLIED, OR STATUTORY, INCLUDING ANY WARRANTY OF MERCHANTABILITY OR FITNESS FOR ANY PARTICULAR PURPOSE. EXCEPT TO THE EXTENT OF THIS INDEMNITY, NEITHER PARTY SHALL BE LIABLE TO THE OTHER FOR ANY INDIRECT, SPECIAL, INCIDENTAL, OR CONSEQUENTIAL DAMAGES.**

The user assumes all responsibility and liability for proper and safe handling of the goods. Further, the user releases LTC from all claims arising from the handling or use of the goods. Due to the open construction of the product, it is the user's responsibility to take any and all appropriate precautions with regard to electrostatic discharge. Also be aware that the products herein may not be regulatory compliant or agency certified (FCC, UL, CE, etc.).

No License is granted under any patent right or other intellectual property whatsoever. **LTC assumes no liability for applications assistance, customer product design, software performance, or infringement of patents or any other intellectual property rights of any kind.**

LTC currently services a variety of customers for products around the world, and therefore this transaction **is not exclusive**.

Please read the DEMO BOARD manual prior to handling the product. Persons handling this product must have electronics training and observe good laboratory practice standards. **Common sense is encouraged.**

This notice contains important safety information about temperatures and voltages. For further safety concerns, please contact a LTC application engineer.

Mailing Address:

Linear Technology
1630 McCarthy Blvd.
Milpitas, CA 95035

Copyright © 2004, Linear Technology Corporation

X-ON Electronics

Largest Supplier of Electrical and Electronic Components

Click to view similar products for [Amplifier IC Development Tools](#) category:

Click to view products by [Analog Devices](#) manufacturer:

Other Similar products are found below :

[EVAL-ADCMP566BCPZ](#) [EVAL-ADCMP606BKSZ](#) [AD8013AR-14-EBZ](#) [AD8033AKS-EBZ](#) [AD8044AR-EBZ](#) [AD8225-EVALZ](#)
[ADA4859-3ACP-EBZ](#) [ADA4862-3YR-EBZ](#) [DEM-OPA-SO-2B](#) [AD744JR-EBZ](#) [AD8023AR-EBZ](#) [AD8030ARJ-EBZ](#) [AD8040ARU-EBZ](#)
[AD8073JR-EBZ](#) [AD813AR-14-EBZ](#) [AD848JR-EBZ](#) [ADA4858-3ACP-EBZ](#) [ADA4922-1ACP-EBZ](#) [551600075-001/NOPB](#) [DEM-OPA-SO-](#)
[2E](#) [THS7374EVM](#) [EVAL-ADCMP553BRMZ](#) [EVAL-ADCMP608BKSZ](#) [MIOP 42109](#) [EVAL-ADCMP609BRMZ](#) [MAX9928EVKIT+](#)
[MAX9636EVKIT+](#) [MAX9611EVKIT](#) [MAX9937EVKIT+](#) [MAX9934TEVKIT+](#) [MAX44290EVKIT#](#) [MAX2644EVKIT](#) [MAX4073EVKIT+](#)
[DEM-OPA-SO-2C](#) [MAX2643EVKIT](#) [ISL28158EVAL1Z](#) [MAX40003EVKIT#](#) [MAX2473EVKIT](#) [MAX2472EVKIT](#) [MAX4223EVKIT](#)
[MAX9700BEVKIT](#) [MADL-011014-001SMB](#) [DC1685A](#) [DEM-OPA-SO-2D](#) [MAX2670EVKIT#](#) [DEM-OPA-SO-1E](#) [AD8137YCP-EBZ](#)
[EVAL-ADA4523-1ARMZ](#) [MAX44242EVKIT#](#) [EVAL-LT5401_32FDAZ](#)