

Low Quiescent Current, High Voltage Step-Down Converter

DESCRIPTION

Demonstration circuit 2221A is a low quiescent current, synchronous buck converter featuring the [LTC®3807EFE](#). This demo board converts a 16V to 38V input voltage to a 12V at 15A output.

The main features of this board include an internal LDO for gate drive power from V_{IN} or $EXTV_{CC}$, RUN and PGOOD pins, a mode selector that allows the converter to run in constant current mode (CCM), pulse-skipping or Burst Mode® operation, and selectable current limit. The DC2221A supports an adjustable output voltage, soft-start and tracking. The wide input voltage range of 16V to 38V is suitable for automotive and distributed DC power systems where low quiescent current is important.

The LTC3807 data sheet gives a complete description of this part, operation and application information. The data sheet must be read in conjunction with this quick start guide for demo circuit 2221A.

The 40V rated MOSFETs, which are used on DC2221A, can be operated at their rated voltage. MOSFETs with higher voltage rating can be used for more safety margin.

The DC2221A supports the LPAK, PowerPAK SO-8 and Power 56 MOSFET packages. The following logic level (SV gate) MOSFETs can be used with DC2221A.

RJK0451DPB	Renesas
BSC093N04LS G	Infineon
Si4124DY	Vishay
FDS8447	Fairchild

For synchronization to an external clock, remove jumper JP2 and apply sync signal on terminal SYNC.

Design files for this circuit board are available at <http://www.linear.com>

LT, LT, LTC, LTM, Burst Mode, Linear Technology and the Linear logo are registered trademarks of Linear Technology Corporation. All other trademarks are the property of their respective owners.

PERFORMANCE SUMMARY Specifications are at $T_A = 25^\circ\text{C}$

PARAMETER	CONDITIONS	VALUE	UNITS
Minimum Input Supply Voltage		16	V
Maximum Input Supply Voltage		38	V
Output Voltage Range	$V_{IN} = 16\text{V to } 38\text{V}$, $I_{OUT} = 0\text{A to } 15\text{A}$	$12 \pm 2\%$	V
Typical Switching Frequency		120	kHz
Typical Output Ripple (V_{OUT} , 12V)	$V_{IN} = 24\text{V}$; $I_{LOAD} = 15\text{A}$	80	mV
Efficiency Typical (V_{OUT} , 12V)	$V_{IN} = 24\text{V}$; $I_{LOAD} = 15\text{A}$	97	%
Supply Quiescent Current	$V_{IN} = 24\text{V}$; $V_{OUT} = 12\text{V}$, $I_O = 0\text{A}$, Burst Mode	110	μA
Supply Shutdown Current	$V_{IN} = 24\text{V}$	38	μA

QUICK START PROCEDURE

Demonstration circuit DC2221A is easy to set up to evaluate the performance of the LTC3807EFE. Refer to Figure 1 for proper measurement equipment setup and follow the procedure below:

NOTE. When measuring the input or output voltage ripple, care must be taken to avoid a long ground lead on the oscilloscope probe. Measure the input or output voltage ripple by touching the probe tip directly across the V_{IN} or V_{OUT} and GND terminals or directly across relevant capacitor. See Figure 2 for proper scope probe technique.

1. Place jumper JP1 in the ON position.

2. With power off, connect the input power supply to V_{IN} and GND.

3. Turn on the power at the input. Check for the proper output voltage:

$$V_{OUT} = 11.9V \text{ to } 12.4V$$

NOTE. If there is no output, temporarily disconnect the load to make sure that the load is not set too high.

4. Once the proper output voltages are established, adjust the load within the operating range and observe the output voltage regulation, ripple voltage, efficiency and other parameters.

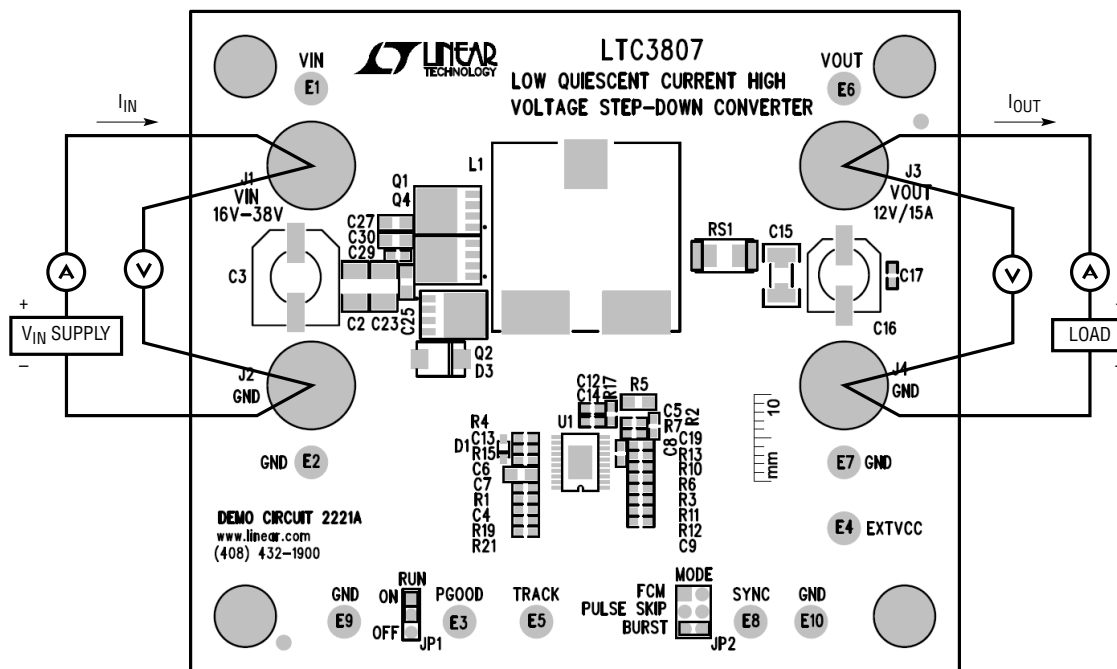

Figure 1. Proper Measurement Equipment Setup

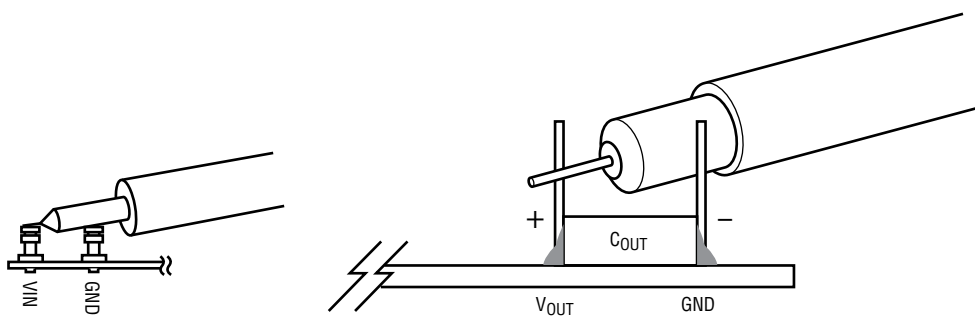

Figure 2. Measuring Input or Output Ripple Across Terminals or Directly Across Bulk Capacitor

QUICK START PROCEDURE

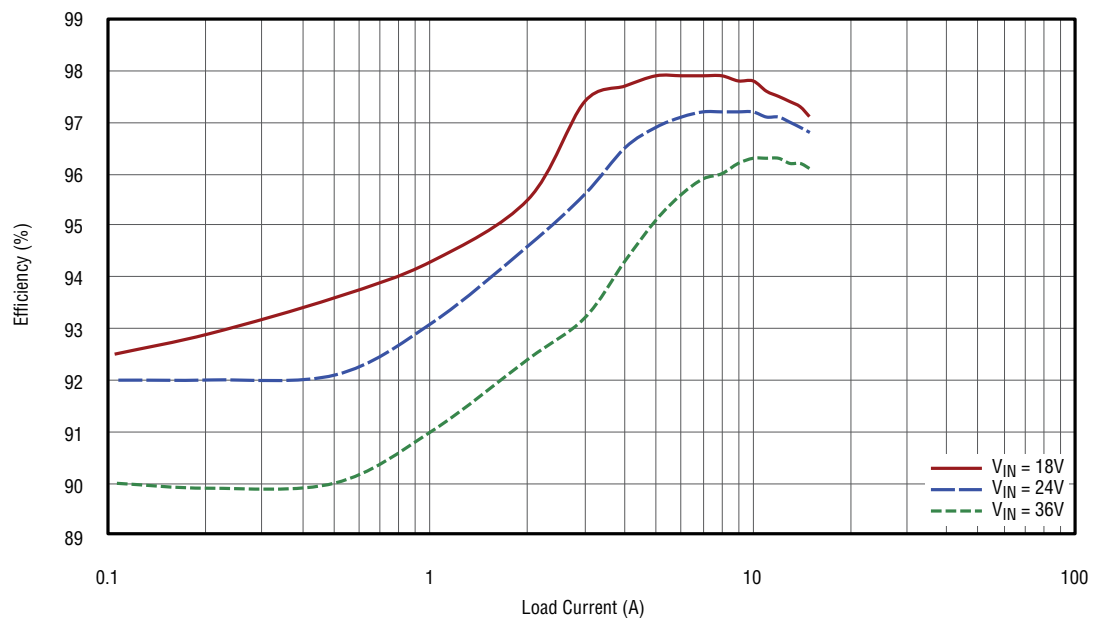

Figure 3. 12V Output, Efficiency vs Load, Burst Mode Operation, V_{IN} 16V, 24V, 36V

DEMO MANUAL DC2221A

PARTS LIST

ITEM	QTY	REFERENCE	PART DESCRIPTION	MANUFACTURER/PART NUMBER
Required Circuit Components				
1	1	Q4	N Channel, MOSFET	INFINEON., BSC093N04LS
2	1	Q2	N Channel, MOSFET	INFINEON., BSC035N04LS
3	1	RS1	RES., 0.003Ω, 1W, 1%, 2512	PANASONIC ERJM1WSF3M0U
4	1	R1	RES., 2.2Ω, 1%, 0603	VISHAY, CRCW06032R20FNEA
5	3	R2, R8, R10	RES., 0Ω, 1%, 0603	VISHAY, CRCW06030000Z0EA
6	2	R4, R20	RES., 100k, 1%, 0603	VISHAY, CRCW0603100KFKEA
7	1	R5	RES., 511k, 1%, 0805	VISHAY, CRCW0805511KFKEA
8	1	R6	RES., 27.4k, 1%, 0603	VISHAY, CRCW060327K4FKEA
9	1	R7	RES., 35.7k, 1%, 0603	VISHAY, CRCW060335K7FKEA
10	1	R13	RES., 10Ω, 1%, 0603	VISHAY, CRCW060310R0FKEA
11	1	R15	RES., 2Ω, 1%, 0603	VISHAY, CRCW06032R00FNEA
12	1	R17	RES., 15.4k, 1%, 10603	VISHAY, CRCW060315K4FKEA
13	1	R18	RES., 1k, 1%, 0603	VISHAY, CRCW06031K00FKEA
14	1	C12	CAP., X7R, 4.7nF, 50V, 10%, 0603	YAGEO CC0603KRX7R9BB472
15	1	C14	CAP., NPO, 47pF, 50V, 5%, 0603	NIC, NMC0603NPO470J50TRPF
16	2	C25, C30	CAP., X7R, 2.2μF, 50V, 10%, 0805	TDK, C2012X7R1H225K125AC
17	1	D1	DIODE, SCHOTTKY, SOD-323	CENTRAL SEMI., CMDSH-4ETR
22	1	L1	IND., 8.6μH,	Pulse., PG1083.103NL
23	1	C16	CAP., Sanyo, 150μF, 16V, 20%	SANYO, 16SVPC150M
24	2	C2, C23	CAP., X7R, 10μF, 50V, 10%, 1210	AVX, 12105C106KAT2A
25	1	C15	CAP., X7R, 10μF, 16V, 10%, 1206	MURATA, GCM31CR71C106KA64L
26	1	C3	CAP., Sanyo, 82μF, 50V, 20%	SANYO, 50HVH82M
27	3	C4, C9, C13	CAP., X7R, 0.1μF, 100V, 10%, 0603	MURATA, GRM188R72A104KA35D
28	1	C5	CAP., COG, 10pF, 50V, 5%, 0603	AVX., 06035A100JAT2A
29	1	C6	CAP., X5R, 4.7μF, 16V, 10%, 0805	MURATA, GRM219R61C475KE15D
30	2	C7, C17	CAP., X7R, 1μF, 16V, 10%, 0603	TDK, C1608X7R1C105K
31	1	C8	CAP., X7R, 1000pF, 10V, 5%, 0603	AVX, 0603ZC102JAT2A
32	1	U1	I.C., LTC3807EFE#PBF,	LINEAR TECH., LTC3807EFE#PBF
Additional Demo Board Circuit Components				
33	0	R3, R9, R11, R12, R19, R21	RES., OPTIONAL	
34		R22, R23, R24, R25 (OPT)	OPTIONAL	
35	0	C11, C18, C19, C20, C21, C22,	OPTIONAL	
36		C24, C26, C27, C28, C29, C31-C34 (OPT)	OPTIONAL	
37	1	R14	RES., 1M, 1% 0805	VISHAY, CRCW08051M00FKEA
38	1	R16	RES., 57.6k, 1% , 0603	VISHAY, CRCW060357K6FKEA
39	0	Q3, D3, Q1 (OPT)	OPTIONAL	
Hardware: For Demo Board Only				
40	1		FAB, PRINTED CIRCUIT BOARD	DEMO CIRCUIT 2221A
41	10	E1-E10	TESTPOINT, TURRET, .094"	MILL-MAX, 2501-2-00-80-00-00-07-0
42	2	JP1, JP2	JMP, 3-PIN, 1 ROW, 0.079"	SULLINS, NRPNO31PAEN-RC
43	2	XJP1, XJP2	SHUNT, .079" CENTER	SAMTEC, 2SN-BK-G
44	4	J1, J2, J3, J4	CONN, BANANA JACK, KEYSTONE-575-4	KEYSTONE, 575-4
45	4	MTGS at 4 Corners	STANDOFF, NYLON .5 1/2"	KEYSTONE, 8833 (SNAP-ON)

dc2221af

SCHEMATIC DIAGRAM

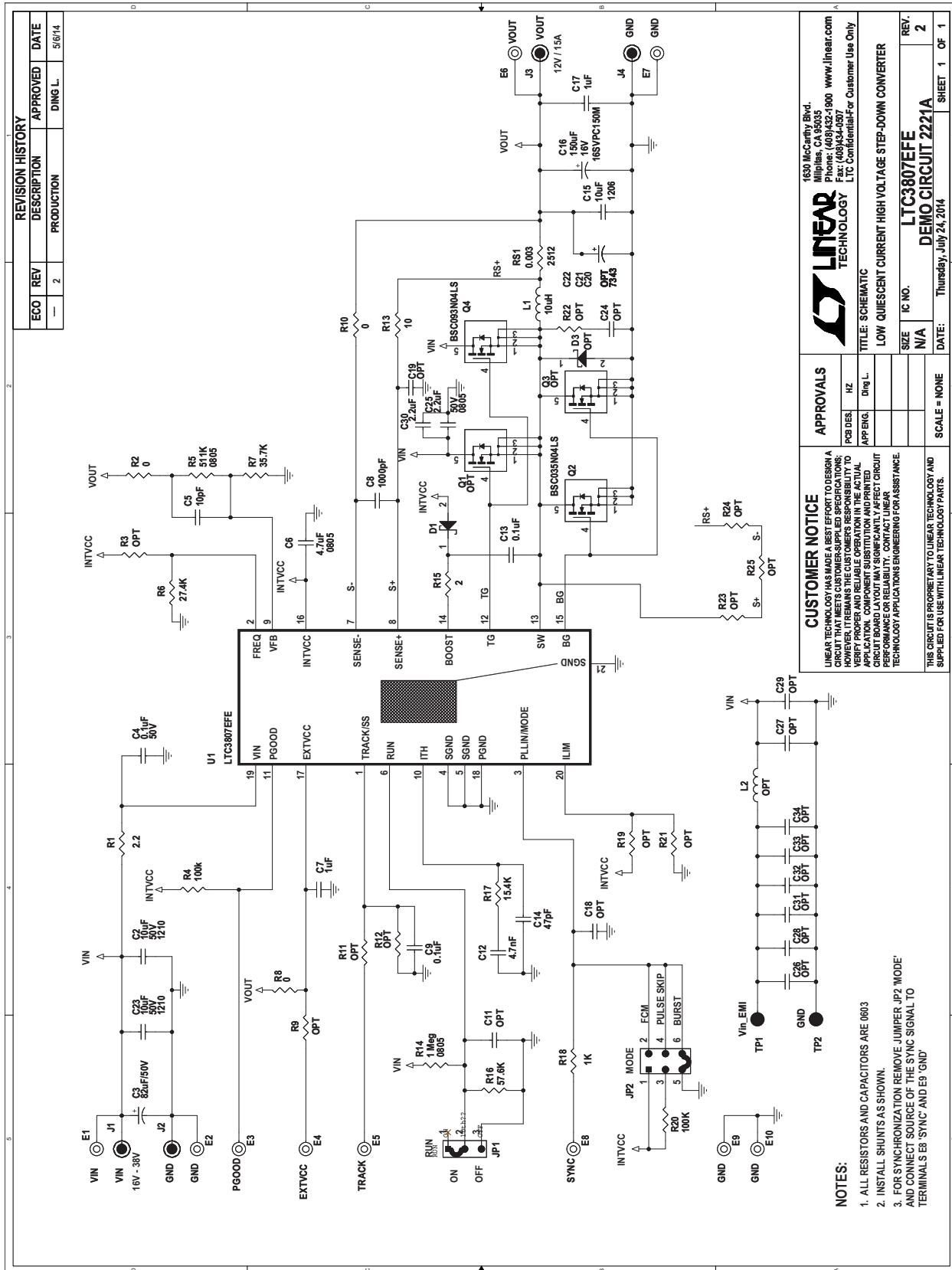

REVISION HISTORY			
ECO	REV	DESCRIPTION	APPROVED DATE
—	2	PRODUCTION	DING L. 5/6/14

		1630 McCarthy Blvd. Milpitas, CA 95035 Phone: (408)432-1900 www.linear.com Fax: (408)434-0572 LTC Confidential For Customer Use Only	
APPROVALS		TITLE: SCHEMATIC	
PCB DES.	HZ	LOW QUIESCENT CURRENT HIGH VOLTAGE STEP-DOWN CONVERTER	
APPNG.	DING L.	SIZE	IC NO.
SCALE = NONE	DATE: Thursday, July 24, 2014	N/A	LTC3807EFE
SHEET 1 OF 1	DEMO CIRCUIT 2221A	REV. 2	DEMO MANUAL DC2221A

CUSTOMER NOTICE

LINEAR TECHNOLOGY HAS MADE A BEST EFFORT TO DESIGN A BOARD LAYOUT THAT WILL NOT SIGNIFICANTLY AFFECT CIRCUIT OPERATION. HOWEVER, IT REMAINS THE CUSTOMER'S RESPONSIBILITY TO VERIFY PROPER AND RELIABLE OPERATION IN THE ACTUAL APPLICATION. COMPONENT SUBSTITUTION AND PRINTED CIRCUIT BOARD LAYOUT MAY SIGNIFICANTLY AFFECT CIRCUIT PERFORMANCE. CONTACT YOUR LOCAL LINEAR TECHNOLOGY APPLICATIONS ENGINEERING FOR ASSISTANCE.

THIS CIRCUIT IS PROPRIETARY TO LINEAR TECHNOLOGY AND SUPPLIED FOR USE WITH LINEAR TECHNOLOGY PARTS.

NOTES:

1. ALL RESISTORS AND CAPACITORS ARE 0603
2. INSTALL SHUNTS AS SHOWN.
3. FOR SYNCHRONIZATION REMOVE JUMPER JP2 'MODE' AND CONNECT SOURCE OF THE SYNC SIGNAL TO TERMINALS 'E8' 'SYNC' AND 'E9' 'GND'

DEMO MANUAL DC2221A

DEMONSTRATION BOARD IMPORTANT NOTICE

Linear Technology Corporation (LTC) provides the enclosed product(s) under the following **AS IS** conditions:

This demonstration board (DEMO BOARD) kit being sold or provided by Linear Technology is intended for use for **ENGINEERING DEVELOPMENT OR EVALUATION PURPOSES ONLY** and is not provided by LTC for commercial use. As such, the DEMO BOARD herein may not be complete in terms of required design-, marketing-, and/or manufacturing-related protective considerations, including but not limited to product safety measures typically found in finished commercial goods. As a prototype, this product does not fall within the scope of the European Union directive on electromagnetic compatibility and therefore may or may not meet the technical requirements of the directive, or other regulations.

If this evaluation kit does not meet the specifications recited in the DEMO BOARD manual the kit may be returned within 30 days from the date of delivery for a full refund. **THE FOREGOING WARRANTY IS THE EXCLUSIVE WARRANTY MADE BY THE SELLER TO BUYER AND IS IN LIEU OF ALL OTHER WARRANTIES, EXPRESSED, IMPLIED, OR STATUTORY, INCLUDING ANY WARRANTY OF MERCHANTABILITY OR FITNESS FOR ANY PARTICULAR PURPOSE. EXCEPT TO THE EXTENT OF THIS INDEMNITY, NEITHER PARTY SHALL BE LIABLE TO THE OTHER FOR ANY INDIRECT, SPECIAL, INCIDENTAL, OR CONSEQUENTIAL DAMAGES.**

The user assumes all responsibility and liability for proper and safe handling of the goods. Further, the user releases LTC from all claims arising from the handling or use of the goods. Due to the open construction of the product, it is the user's responsibility to take any and all appropriate precautions with regard to electrostatic discharge. Also be aware that the products herein may not be regulatory compliant or agency certified (FCC, UL, CE, etc.).

No License is granted under any patent right or other intellectual property whatsoever. **LTC assumes no liability for applications assistance, customer product design, software performance, or infringement of patents or any other intellectual property rights of any kind.**

LTC currently services a variety of customers for products around the world, and therefore this transaction **is not exclusive**.

Please read the DEMO BOARD manual prior to handling the product. Persons handling this product must have electronics training and observe good laboratory practice standards. **Common sense is encouraged.**

This notice contains important safety information about temperatures and voltages. For further safety concerns, please contact a LTC application engineer.

Mailing Address:

Linear Technology
1630 McCarthy Blvd.
Milpitas, CA 95035

Copyright © 2004, Linear Technology Corporation

X-ON Electronics

Largest Supplier of Electrical and Electronic Components

Click to view similar products for [Power Management IC Development Tools](#) category:

Click to view products by [Analog Devices](#) manufacturer:

Other Similar products are found below :

[EVAL-ADM1168LQEBZ](#) [EVB-EP5348UI](#) [MIC23451-AAAYFL EV](#) [MIC5281YMME EV](#) [DA9063-EVAL](#) [ADP122-3.3-EVALZ](#) [ADP130-0.8-EVALZ](#) [ADP130-1.2-EVALZ](#) [ADP130-1.5-EVALZ](#) [ADP130-1.8-EVALZ](#) [ADP1714-3.3-EVALZ](#) [ADP1716-2.5-EVALZ](#) [ADP1740-1.5-EVALZ](#) [ADP1752-1.5-EVALZ](#) [ADP1828LC-EVALZ](#) [ADP1870-0.3-EVALZ](#) [ADP1871-0.6-EVALZ](#) [ADP1873-0.6-EVALZ](#) [ADP1874-0.3-EVALZ](#) [ADP1882-1.0-EVALZ](#) [ADP199CB-EVALZ](#) [ADP2102-1.25-EVALZ](#) [ADP2102-1.875EVALZ](#) [ADP2102-1.8-EVALZ](#) [ADP2102-2-EVALZ](#) [ADP2102-3-EVALZ](#) [ADP2102-4-EVALZ](#) [ADP2106-1.8-EVALZ](#) [ADP2147CB-110EVALZ](#) [AS3606-DB](#) [BQ24010EVM](#) [BQ24075TEVM](#) [BQ24155EVM](#) [BQ24157EVM-697](#) [BQ24160EVM-742](#) [BQ24296MEVM-655](#) [BQ25010EVM](#) [BQ3055EVM](#) [NCV891330PD50GEVB](#) [ISLUSBI2CKIT1Z](#) [LM2744EVAL](#) [LM2854EVAL](#) [LM3658SD-AEV/NOPB](#) [LM3658SDEV/NOPB](#) [LM3691TL-1.8EV/NOPB](#) [LM4510SDEV/NOPB](#) [LM5033SD-EVAL](#) [LP38512TS-1.8EV](#) [EVAL-ADM1186-1MBZ](#) [EVAL-ADM1186-2MBZ](#)