

# LTC3789EGN

## 300W 2-Phase Interleaved Synchronous Buck-Boost Converter

### DESCRIPTION

Demonstration circuit 2253A is a high power, high efficiency, 2-phase interleaved synchronous buck-boost converter with a 6V to 36V input range. It can supply a 25A maximum load current with a 12V output. This demo board features 2x LTC3789EGN controllers.

The **LTC<sup>®</sup>3789** is a high performance current-mode buck-boost switching regulator controller that operates from input voltages above, below or equal to the output voltage, while an output current feedback loop provides support for output current limit and battery charging. With a wide 4V to 38V (40V maximum) input and output range and seamless, low noise transitions between operating regions, the LTC3789 is ideal for automotive, telecom and battery-powered systems.

The light load operating mode of the controller is determined through the MODE/PLLIN pin. By default, the forced continuous mode (CCM) operation is pre-selected on this demo board. Switching frequency is preset at about 200kHz. Two paralleling schemes are available for this demo board and by default the method of shared I<sub>TH</sub> pins is adopted. Please refer to the Quick Start Procedure section for the optional Master-Slave paralleling scheme. To shut down the converter, force the RUN pin below 1.2V (JP1: OFF) Please refer to LTC3789 data sheet for more detailed information.

**Design files for this circuit board are available at <http://www.linear.com/demo/DC2253A>**

LT, LTC, LTM, Linear Technology and the Linear logo are registered trademarks of Linear Technology Corporation. All other trademarks are the property of their respective owners.

### PERFORMANCE SUMMARY Specifications are at T<sub>A</sub> = 25°C

PARAMETER	CONDITION	VALUE
Input Voltage Range		6V to 36V
Output Voltage, V <sub>OUT</sub>	V <sub>IN</sub> = 6V to 36V, I <sub>OUT</sub> = 0A to 25A	12V ±2%
Maximum Output Current, I <sub>OUT</sub>	V <sub>IN</sub> = 6V to 36V, V <sub>OUT</sub> = 12V	25A
Typical Output Ripple	V <sub>IN</sub> = 36V, I <sub>OUT</sub> = 25A (20MHz BW) V <sub>IN</sub> = 12V, I <sub>OUT</sub> = 25A (20MHz BW) V <sub>IN</sub> = 6V, I <sub>OUT</sub> = 25A (20MHz BW)	36mV <sub>p-p</sub> 200mV <sub>p-p</sub> 380mV <sub>p-p</sub>
Typical Efficiency	V <sub>IN</sub> = 12V, V <sub>OUT</sub> = 12V, I <sub>OUT</sub> = 25A, see Figure 3	97.8%
Typical Switching Frequency		200kHz

## QUICK START PROCEDURE

Demonstration circuit 2253A is easy to set up to evaluate the performance of the LTC3789EGN. Refer to Figure 1 for the proper measurement equipment setup and follow the procedure below:

1. With power off, connect the input power supply to  $V_{IN}$  (6V to 36V) and GND (input return).
2. Connect the 12V output load between  $V_{OUT}$  and GND (Initial load: no load).
3. Connect the DVMs to the input and output. Set the default jumper position, JP1: ON.
4. Turn on the input power supply and check for the proper output voltages.  $V_{OUT}$  should be  $12V \pm 2\%$ .
5. Once the proper output voltages are established, adjust the loads within the operating range and observe the output voltage regulation, ripple voltage and other parameters.

Note: When measuring the output or input voltage ripple, do not use the long ground lead on the oscilloscope probe. See Figure 2 for the proper scope probe technique. Short, stiff leads need to be soldered to the (+) and (-) terminals of an output capacitor. The probe's ground ring needs to touch the (-) lead and the probe tip needs to touch the (+) lead.

## Optional Master-Slave Paralleling Scheme

Besides the default paralleling scheme by tying the  $I_{TH}$  pins together, another optional Master-Slave scheme can be achieved on the demo board to obtain a better sharing of the inductor currents and output currents between phases. Please refer to the schematic in Page 8. To implement it,

1. Remove R67, R69 and R70.
2. Populate R68, R71 with  $0\Omega$ .
3. Set  $R_{FB3}$  5~10% higher than  $R_{FB1}$  and set  $R_{FB4} = R_{FB2}$ .
4. Choose the current reference divider R65 and R66 so that when the  $V_{out}$  is regulated, the voltage drop on R65 is equal to  $V_{ILIM}$ , where  $V_{ILIM}$  is the output current limit threshold voltage. For example, when  $I_{LIM}$  pin is grounded,  $V_{ILIM} = 50mV$ . For  $V_{OUT} = 12V$ , select  $R65 = 100\Omega$  and  $R66 = 24k\Omega$  and then the voltage drop on R65 will be 50mV.

**QUICK START PROCEDURE**

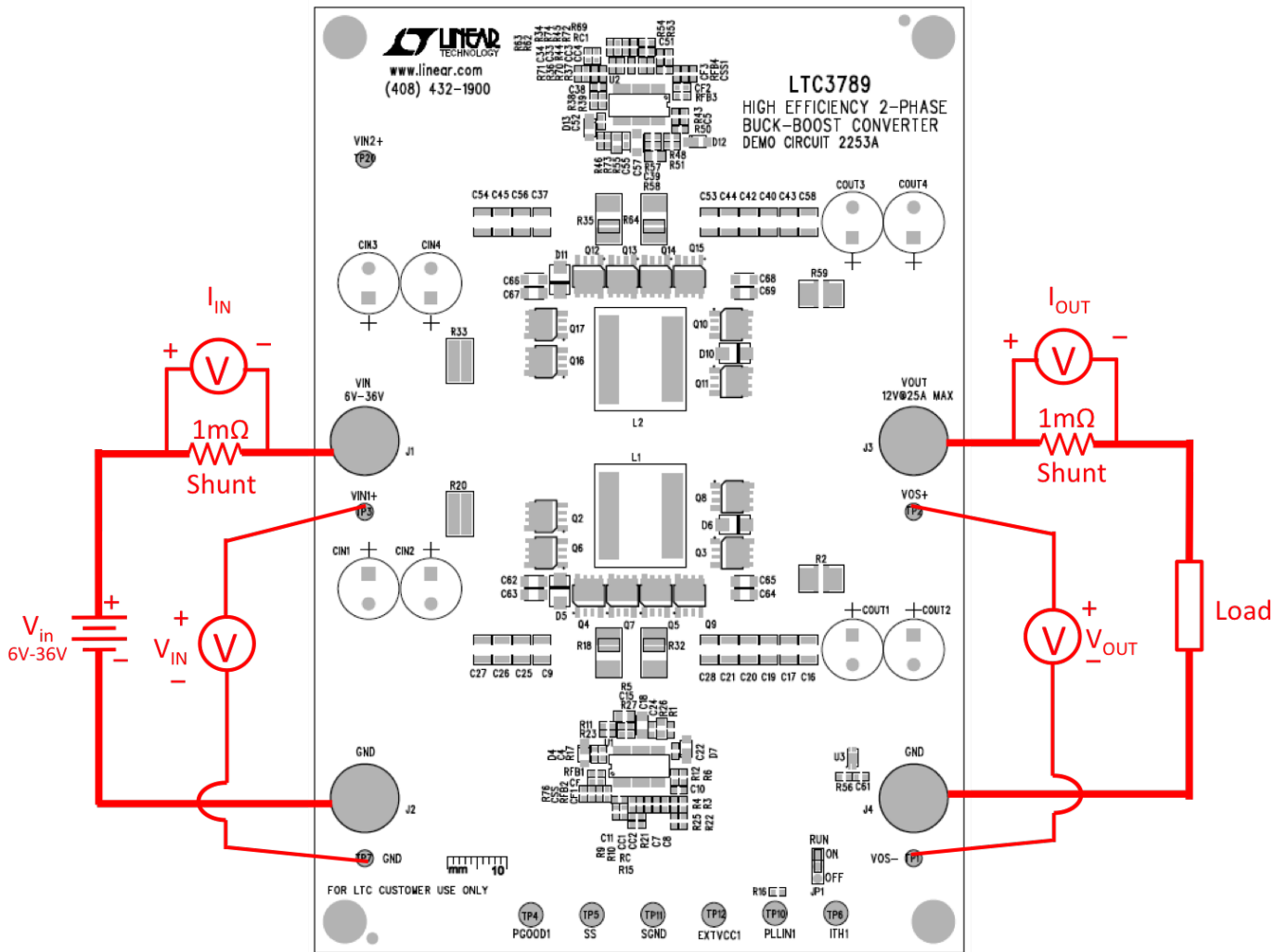

Figure 1. Proper Measurement Equipment Setup

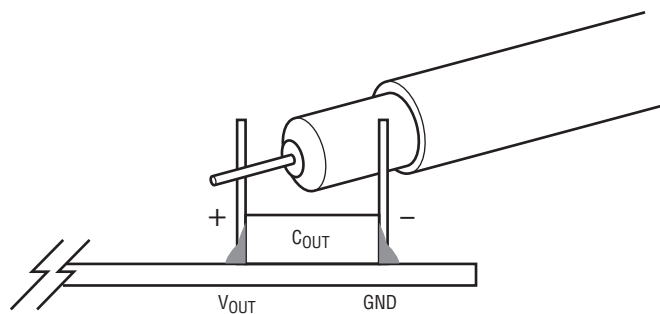

Figure 2. Measuring Output Voltage Ripple

## QUICK START PROCEDURE

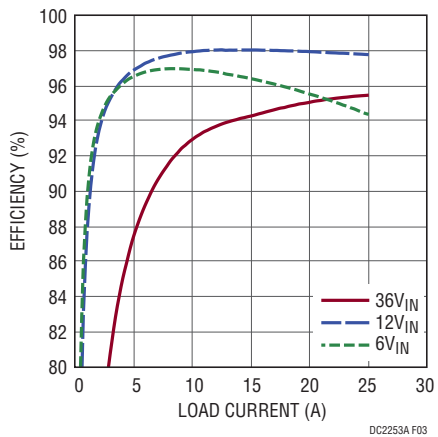

Figure 3. Efficiency vs Load Current ( $V_{OUT} = 12V$ , CCM)

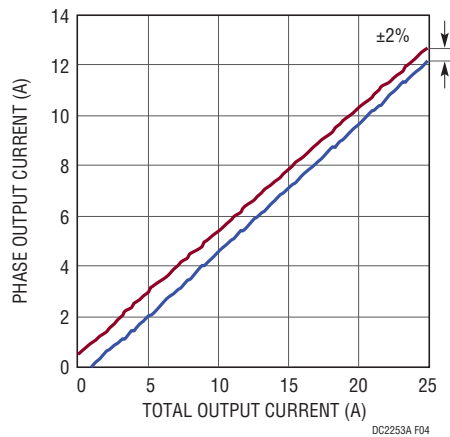

Figure 4. Output Current Sharing ( $V_{IN} = 6V$ ,  $V_{OUT} = 12V$ )

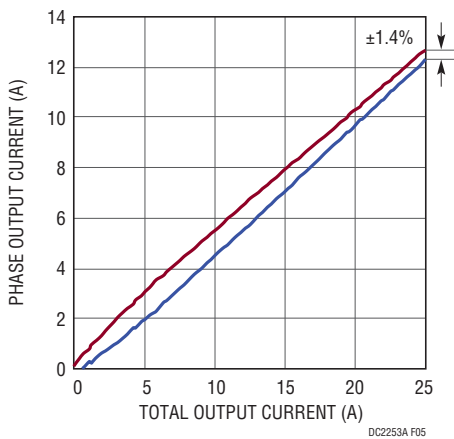

Figure 5. Output Current Sharing ( $V_{IN} = 12V$ ,  $V_{OUT} = 12V$ )

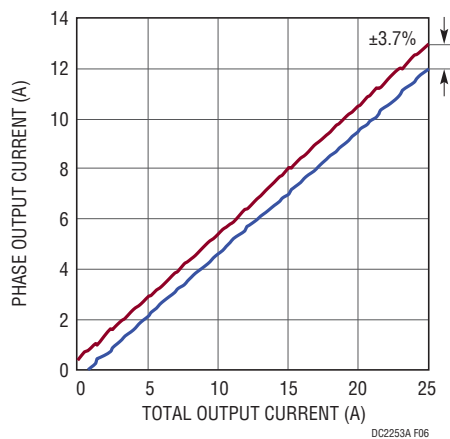

Figure 6. Output Current Sharing ( $V_{IN} = 36V$ ,  $V_{OUT} = 12V$ )

**QUICK START PROCEDURE**

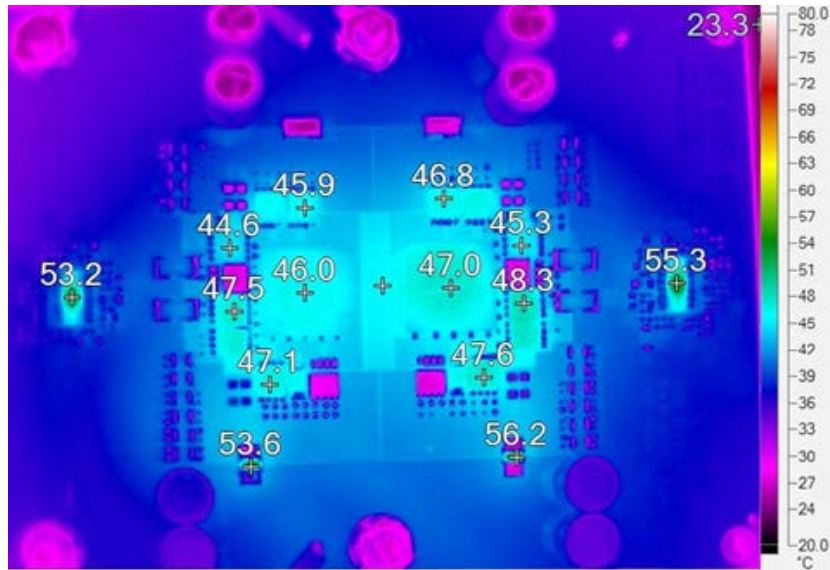

Figure 7. Thermal Performance ( $V_{IN} = 12V$ ,  $V_{OUT} = 12V$ , 25A Load, No Air Flow)

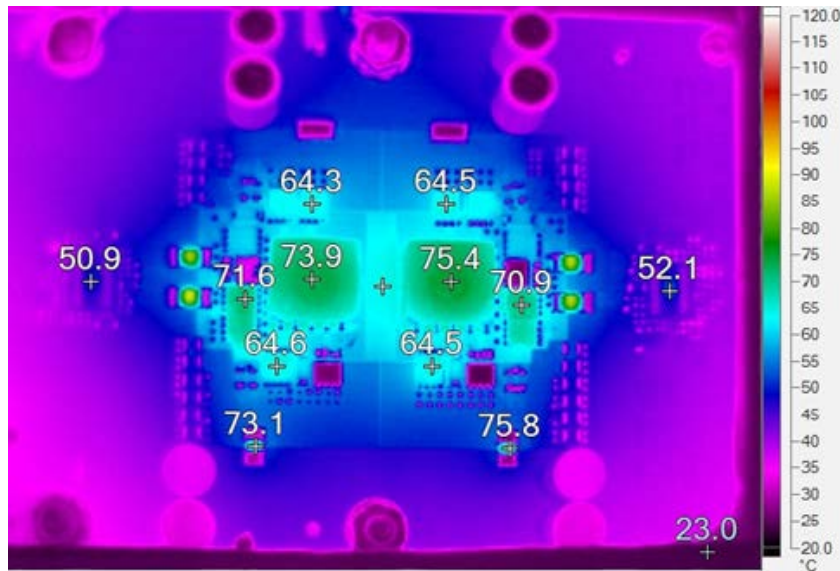

Figure 8. Thermal Performance ( $V_{IN} = 6V$ ,  $V_{OUT} = 12V$ , 25A Load, 200LFM)

## QUICK START PROCEDURE

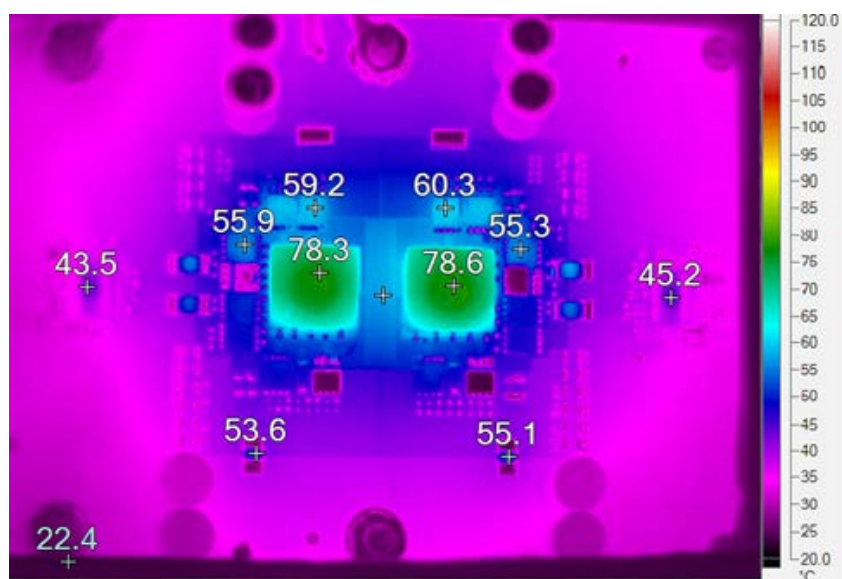

Figure 9. Thermal Performance ( $V_{IN} = 36V$ ,  $V_{OUT} = 12V$ , 25A Load, 200LFM)

## PARTS LIST

ITEM	QTY	REFERENCE	PART DESCRIPTION	MANUFACTURER/PART NUMBER
1	2	CC1, CC4	CAP., COG, 100pF, 50V, 10% 0603	AVX, 06035A101KAT2A
2	2	CC2, CC3	CAP., X7R, 0.01µF, 50V, 10% 0603	AVX, 06035C103KAT2A
3	5	CSS1, C15, C39, C61, CSS	CAP., X7R, 0.1µF, 50V, 10% 0603	AVX, 06035C104KAT2A
4	0	CF1, CF2, CF3, C7, C8, CF, C23	CAP., 0603 OPTIONAL	
5		C29, C30, C31-C34		
6		C12, C13, C59, C60	CAP., 1206 OPTIONAL	
7		C14, C35, C36, C41, C46-C50	CAP., 1210 OPTIONAL	
8	4	C62, C63, C66, C67	CAP., X7R, 2.2µF, 50V, 10% 1206	KEMET C1206C225K5RACTU
9	4	C64, C65, C68, C69	CAP., X7R, 2.2µF, 25V, 10% 1206	AVX 12063C225KAT2A
10	2	C11, C51	CAP., NPO, 68pF, 50V, 10% 0603	AVX, 06035A680KAT2A
11	2	C10, C38	CAP., X5R, 4.7µF, 10V, 10% 0603	AVX, 0603ZD475KAT2A
12	2	C24, C55	CAP., X7R, 1µF, 16V, 20% 0603	AVX, 0603YC105MAT2A
13	4	CIN1, CIN2, CIN3, CIN4	CAP., ALUM, 270µF, 50V, 20%	SUN ELECTRONICS, 50ME270WX+T
14	4	COUT1, COUT2, COUT3, COUT4	CAP., OS-CON, 330µF, 25V, 20%	SANYO, 25SEPF330M
15	12	C16, C17, C19, C20, C21, C28	CAP., X7R, 22µF, 16V, 20% 1210	AVX, 1210YC226MAT2A
16		C40, C42, C43, C44, C53, C58		
17	4	C4, C5, C22, C52	CAP., X7R, 0.22µF, 16V, 20% 0603	AVX, 0603YC224MAT2A
18	8	C9, C25, C26, C27	CAP., X7R, 3.3µF, 50V, 20% 1210	AVX, 12105C335MAT2A
19		C37, C45, C54, C56		
20	2	C18, C57	CAP., X5R, 10µF, 6.3V, 20% 1206	AVX, 12066D106MAT2A
21	4	D4, D7, D12, D13	DIODE, SCHOTTKY 1A 60V POWERDI123	DIODE INC., DFSL160-7
22	4	D5, D6, D10, D11	DIODE, SCHOTTKY 3A 40V SMA	DIODE INC., B340A-13-F
23	1	D8	DIODE, ZENER 5.1V 350MW SOT23-3	DIODE INC., BZX84C5V1-7-F
24	1	JP1	HEADER, 3 PIN 0.079 SINGLE ROW	SAMTEC, TMM-103-02-L-S
25	1	XJP1	SHUNT, .079" CENTER	SAMTEC, 2SN-BK-G
26	4	J2, J4, J5, J6	STUD, TESTPIN	PEM KFH-032-10
27	8	J1, J2, J3, J4 (x2)	NUT, BRASS 10-32	ANY #10-32
28	4	J1, J2, J3, J4	RING, LUG #10	KEYSTONE, 8205, #10
29	4	J1, J2, J3, J4	WASHER, TIN PLATED BRASS	ANY #10, #10EXT BZ TN
30	2	L1, L2	INDUCTOR, 3µH	COILCRAFT LNC. XAL1580-302ME
31	6	Q2, Q4, Q6, Q16, Q17, Q12	MOSFET N-CHANNEL	INFINEON, BSC027N04LS
32	6	Q3, Q5, Q10, Q15, Q9, Q14	MOSFET N-CHANNEL	INFINEON, BSC010NE2LS
33	0	Q7, Q8, Q11, Q13 OPT		
34	1	RFB1	RES., CHIP., 113k, 0.1W, 1% 0603	YAGEO, RC0603FR-07113KL
35	1	RFB2	RES., CHIP., 8.06k, 0.1W, 1% 0603	YAGEO, RC0603FR-078K06L
36	4	R18, R32, R35, R64	RES., CHIP., 0.006Ω, 2W, 1% 2512	SUSUMU., KRL3264E-C-R006
37	2	R2, R59	Sense RES 0.003Ω 1W 1% 2512 SMD	YAGEO, PR2512FKF070R003L
38	12	R3, R4, R9, R10, R13, R14, R36	RES., CHIP., 100Ω, 0.1W, 1% 0603	YAGEO, RC0603FR-07100RL
39		R37, R40, R41, R53, R54		
40	2	R5, R58	RES., CHIP, 5.1Ω, 0.1W, 5% 0805	YAGEO, RC0805JR-075R1L
41	0	R6, R12, R15, R22, R28, R29, R38, R39	RES., 0603, OPTIONAL	
42		R63, R68, R71, R74, R75, R65, R66, R73		

# DEMO MANUAL DC2253A

## PARTS LIST

ITEM	QTY	REFERENCE	PART DESCRIPTION	MANUFACTURER/PART NUMBER
43		RFB3, RFB4		
44		R28, R29, R60, R61	RES., 1206, OPTIONAL	
45	2	R7, R50	RES., CHIP., 100k, 0.1W, 1% 0603	YAGEO, RC0603FR-07100KL
46	1	R8	RES., CHIP., 10 $\Omega$ , 0.1W, 5% 0603	YAGEO, RC0603JR-0710RL
47	2	R26, R55	RES., CHIP., 10 $\Omega$ , 0.1W, 5% 0805	YAGEO, RC0805JR-0710RL
48	17	R1, R11, R17, R23, R25	RES., CHIP., 0 $\Omega$ 1% 0603	YAGEO, RC0603FR-070RL
49		R27, R43, R46, R48, R51, R76		
50		R57, R62, R67, R69, R70, R72		
51	1	R20, R33	RES., CHIP., 0 $\Omega$ 2512	TEPRO, RN5326
52	2	R16, R45	RES., CHIP., 1k, 0.1W, 1% 0603	YAGEO, RC0603FR-071KL
53	6	RC1, R21, R24, R34, R44, RC	RES., CHIP., 10k, 0.1W, 1% 0603	YAGEO, RC0603FR-0710KL
54	1	R30	RES., CHIP., 41.2k, 0.1W, 1% 0603	YAGEO, RC0603FR-0741K2L
55	1	R31	RES., CHIP., 12.1k, 0.1W, 1% 0603	YAGEO, RC0603FR-0712K1L
56	1	R56	RES., CHIP., 499k, 0.1W, 1% 0603	YAGEO, RC0603FR-07499KL
57	5	TP1, TP2, TP3, TP7, TP20	TESTPOINT, TURRET, .061" PBF	MILL-MAX, 2308-2-00-80-00-00-07-0
58	6	TP4, TP5, TP6, TP10-TP12	TESTPOINT, TURRET, .094" PBF	MILL-MAX, 2501-2-00-80-00-00-07-0
59	2	U1, U2	I.C., LTC3789EGN SSOP N	LINEAR TECH., LTC3789EGN#PBF
60	1	U3	I.C., LTC6908CDCB-1 2mm x 3mm	LINEAR TECH., LTC6908CDCB-1
61	4	MTGS AT 4 CORNERS	STAND-OFF, NYLON 0.5"	KEYSTONE, 8833 (SNAP ON)
62	1		FAB, PRINTED CIRCUIT BOARD	DEMO CIRCUIT FT228A
63	2	STENCILS	STENCIL BOTH SIDES	STENCIL FT228A



SCHEMATIC DIAGRAM

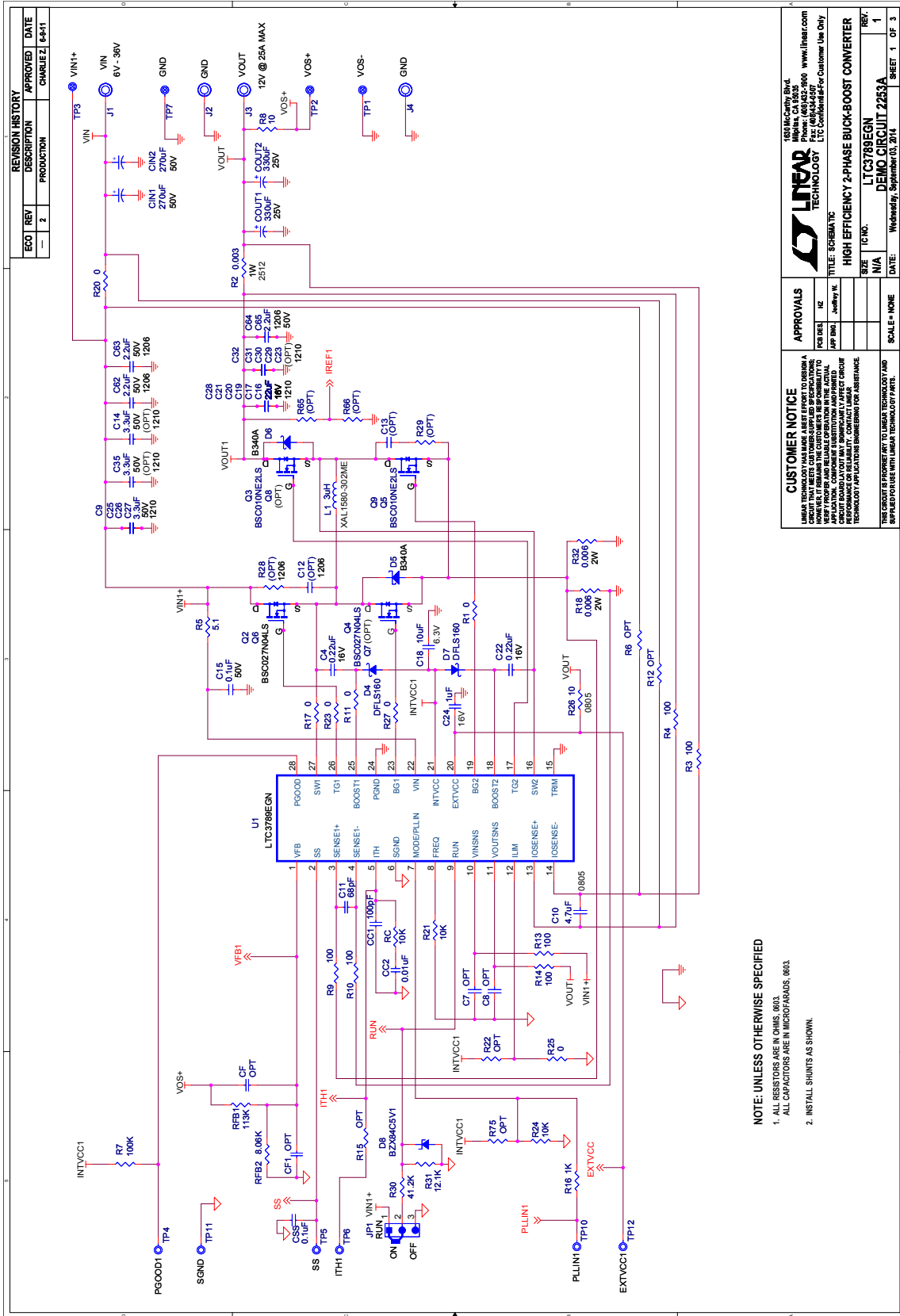

REVISION HISTORY				
ECO	REV	DESCRIPTION	APPROVED	DATE
—	2	PRODUCTION	CHARLIE Z.	6-8-11

**CUSTOMER NOTICE**  
 LINEAR TECHNOLOGY HAS MADE A BEST EFFORT TO DESIGN A DEMO BOARD FOR THE CUSTOMER'S USE. HOWEVER, IT REMAINS THE CUSTOMER'S RESPONSIBILITY TO DESIGN AND TEST THE BOARD FOR THEIR INTENDED APPLICATION. CUSTOMERS ARE REQUESTED TO CONTACT LINEAR TECHNOLOGY APPLICATION ENGINEERING FOR ASSISTANCE.

**APPROVALS**

DESIGNER	KZ
APP. ENG.	Jedrey W.

**LINEAR TECHNOLOGY**  
 100 McCarty Rd.  
 Milpitas, CA 95035  
 Phone: (408) 328-9600 www.linear.com  
 Fax: (408) 328-9601  
 LIT-2253 Rev. 1.0  
 LIT-Confidential For Customer Use Only

**TITLE: SCHEMATIC**  
**SIZE: 11CMO**  
**DATE: Wednesday, September 03, 2014**

**LTC3789EGN**  
**DEMO CIRCUIT 2253A**

SCALE: NONE  
 SHEET 1 OF 3

**NOTE: UNLESS OTHERWISE SPECIFIED**  
 1. ALL RESISTORS ARE IN OHMS, 0603.  
 ALL CAPACITORS ARE IN MICROFARADS, 0603.  
 2. INSTALL SHUNTS AS SHOWN.

# DEMO MANUAL DC2253A

## SCHEMATIC DIAGRAM

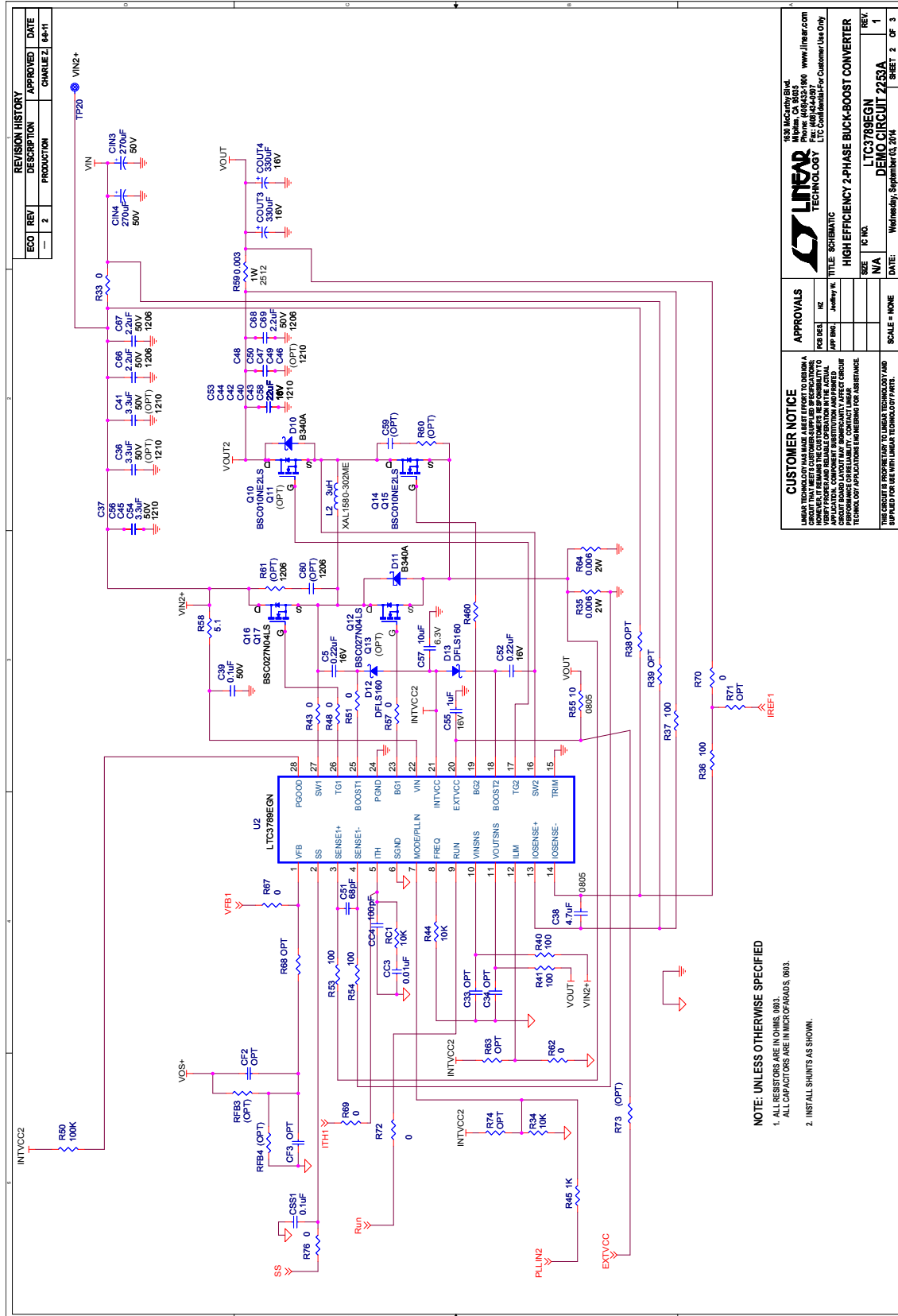

**NOTE: UNLESS OTHERWISE SPECIFIED**  
 1. ALL RESISTORS ARE IN OHMS UNLESS OTHERWISE SPECIFIED.  
 2. INSTALLED SHUNTS AS SHOWN.

ECO	REV	DESCRIPTION	APPROVED	DATE
—	2	PRODUCTION	CHARLEZ	6-8-11

APPROVALS		TITLE		SCALE	
DESIGN	REV	REV	NO.	SCALE	DATE
APP DES	APP REV	APP DES	APP REV	N/A	Wednesday, September 03, 2014
<b>CUSTOMER NOTICE</b>				<b>LTC3789EGN</b>	
LINEAR TECHNOLOGY HAS MADE A BEST EFFORT TO DESIGN A SCHEMATIC THAT REPRESENTS THE CUSTOMER'S REQUIREMENTS. HOWEVER, IT REMAINS THE CUSTOMER'S RESPONSIBILITY TO PROVIDE THE CORRECT COMPONENTS, PARTS LIST, APPLICATION INFORMATION, AND TO PROVIDE THE CORRECT CIRCUIT BOARD LAYOUT. CONTACT LINEAR TECHNOLOGY APPLICATIONS ENGINEERING FOR ASSISTANCE.				<b>DEMO CIRCUIT 2253A</b>	
THIS CIRCUIT IS PROPRIETARY TO LINEAR TECHNOLOGY AND IS SUPPLIED FOR USE WITH LINEAR TECHNOLOGY PARTS.				SHEET 2 OF 3	

**CUSTOMER NOTICE**  
 LINEAR TECHNOLOGY HAS MADE A BEST EFFORT TO DESIGN A SCHEMATIC THAT REPRESENTS THE CUSTOMER'S REQUIREMENTS. HOWEVER, IT REMAINS THE CUSTOMER'S RESPONSIBILITY TO PROVIDE THE CORRECT COMPONENTS, PARTS LIST, APPLICATION INFORMATION, AND TO PROVIDE THE CORRECT CIRCUIT BOARD LAYOUT. CONTACT LINEAR TECHNOLOGY APPLICATIONS ENGINEERING FOR ASSISTANCE.  
 THIS CIRCUIT IS PROPRIETARY TO LINEAR TECHNOLOGY AND IS SUPPLIED FOR USE WITH LINEAR TECHNOLOGY PARTS.

**SCHEMATIC DIAGRAM**

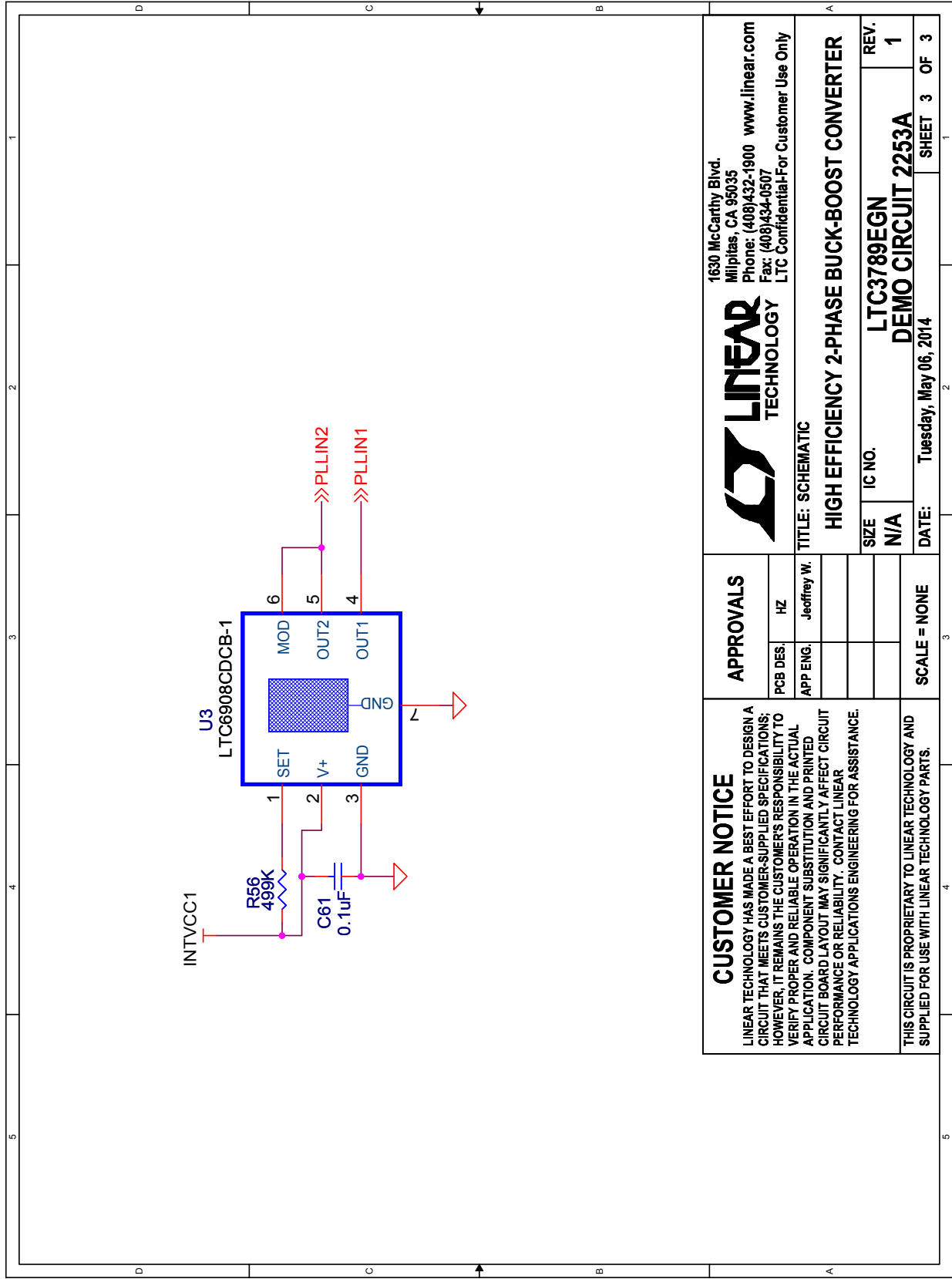

<b>CUSTOMER NOTICE</b>		<b>APPROVALS</b>		<b>LINEAR TECHNOLOGY</b>	
LINEAR TECHNOLOGY HAS MADE A BEST EFFORT TO DESIGN A CIRCUIT THAT MEETS CUSTOMER-SUPPLIED SPECIFICATIONS; HOWEVER, IT REMAINS THE CUSTOMER'S RESPONSIBILITY TO VERIFY PROPER AND RELIABLE OPERATION IN THE ACTUAL APPLICATION. COMPONENT SUBSTITUTION AND PRINTED CIRCUIT BOARD LAYOUT MAY SIGNIFICANTLY AFFECT CIRCUIT PERFORMANCE OR RELIABILITY. CONTACT LINEAR TECHNOLOGY APPLICATIONS ENGINEERING FOR ASSISTANCE.		PCB DES.	HZ	1630 McCarthy Blvd. Milpitas, CA 95035 Phone: (408)432-1900 www.linear.com Fax: (408)434-0507 LTC Confidential-For Customer Use Only	
THIS CIRCUIT IS PROPRIETARY TO LINEAR TECHNOLOGY AND SUPPLIED FOR USE WITH LINEAR TECHNOLOGY PARTS.		APP ENG.	Jeffrey W.	<b>TITLE: SCHEMATIC</b>	
				<b>HIGH EFFICIENCY 2-PHASE BUCK-BOOST CONVERTER</b>	
				SIZE	IC NO.
				N/A	LTC3789EGN
				DATE:	REV.
				Tuesday, May 06, 2014	1
		SCALE = NONE		<b>DEMO CIRCUIT 2253A</b>	
				SHEET 3 OF 3	

# DEMO MANUAL DC2253A

---

## DEMONSTRATION BOARD IMPORTANT NOTICE

Linear Technology Corporation (LTC) provides the enclosed product(s) under the following **AS IS** conditions:

This demonstration board (DEMO BOARD) kit being sold or provided by Linear Technology is intended for use for **ENGINEERING DEVELOPMENT OR EVALUATION PURPOSES ONLY** and is not provided by LTC for commercial use. As such, the DEMO BOARD herein may not be complete in terms of required design-, marketing-, and/or manufacturing-related protective considerations, including but not limited to product safety measures typically found in finished commercial goods. As a prototype, this product does not fall within the scope of the European Union directive on electromagnetic compatibility and therefore may or may not meet the technical requirements of the directive, or other regulations.

If this evaluation kit does not meet the specifications recited in the DEMO BOARD manual the kit may be returned within 30 days from the date of delivery for a full refund. **THE FOREGOING WARRANTY IS THE EXCLUSIVE WARRANTY MADE BY THE SELLER TO BUYER AND IS IN LIEU OF ALL OTHER WARRANTIES, EXPRESSED, IMPLIED, OR STATUTORY, INCLUDING ANY WARRANTY OF MERCHANTABILITY OR FITNESS FOR ANY PARTICULAR PURPOSE. EXCEPT TO THE EXTENT OF THIS INDEMNITY, NEITHER PARTY SHALL BE LIABLE TO THE OTHER FOR ANY INDIRECT, SPECIAL, INCIDENTAL, OR CONSEQUENTIAL DAMAGES.**

The user assumes all responsibility and liability for proper and safe handling of the goods. Further, the user releases LTC from all claims arising from the handling or use of the goods. Due to the open construction of the product, it is the user's responsibility to take any and all appropriate precautions with regard to electrostatic discharge. Also be aware that the products herein may not be regulatory compliant or agency certified (FCC, UL, CE, etc.).

No License is granted under any patent right or other intellectual property whatsoever. **LTC assumes no liability for applications assistance, customer product design, software performance, or infringement of patents or any other intellectual property rights of any kind.**

LTC currently services a variety of customers for products around the world, and therefore this transaction **is not exclusive**.

**Please read the DEMO BOARD manual prior to handling the product.** Persons handling this product must have electronics training and observe good laboratory practice standards. **Common sense is encouraged.**

This notice contains important safety information about temperatures and voltages. For further safety concerns, please contact a LTC application engineer.

Mailing Address:

Linear Technology  
1630 McCarthy Blvd.  
Milpitas, CA 95035

Copyright © 2004, Linear Technology Corporation

## X-ON Electronics

Largest Supplier of Electrical and Electronic Components

*Click to view similar products for [Power Management IC Development Tools](#) category:*

*Click to view products by [Analog Devices](#) manufacturer:*

Other Similar products are found below :

[EVAL-ADM1168LQEBZ](#) [EVB-EP5348UI](#) [MIC23451-AAAYFL EV](#) [MIC5281YMME EV](#) [DA9063-EVAL](#) [ADP122-3.3-EVALZ](#) [ADP130-0.8-EVALZ](#) [ADP130-1.2-EVALZ](#) [ADP130-1.5-EVALZ](#) [ADP130-1.8-EVALZ](#) [ADP1714-3.3-EVALZ](#) [ADP1716-2.5-EVALZ](#) [ADP1740-1.5-EVALZ](#) [ADP1752-1.5-EVALZ](#) [ADP1828LC-EVALZ](#) [ADP1870-0.3-EVALZ](#) [ADP1871-0.6-EVALZ](#) [ADP1873-0.6-EVALZ](#) [ADP1874-0.3-EVALZ](#) [ADP1882-1.0-EVALZ](#) [ADP199CB-EVALZ](#) [ADP2102-1.25-EVALZ](#) [ADP2102-1.875EVALZ](#) [ADP2102-1.8-EVALZ](#) [ADP2102-2-EVALZ](#) [ADP2102-3-EVALZ](#) [ADP2102-4-EVALZ](#) [ADP2106-1.8-EVALZ](#) [ADP2147CB-110EVALZ](#) [AS3606-DB](#) [BQ24010EVM](#) [BQ24075TEVM](#) [BQ24155EVM](#) [BQ24157EVM-697](#) [BQ24160EVM-742](#) [BQ24296MEVM-655](#) [BQ25010EVM](#) [BQ3055EVM](#) [NCV891330PD50GEVB](#) [ISLUSBI2CKIT1Z](#) [LM2744EVAL](#) [LM2854EVAL](#) [LM3658SD-AEV/NOPB](#) [LM3658SDEV/NOPB](#) [LM3691TL-1.8EV/NOPB](#) [LM4510SDEV/NOPB](#) [LM5033SD-EVAL](#) [LP38512TS-1.8EV](#) [EVAL-ADM1186-1MBZ](#) [EVAL-ADM1186-2MBZ](#)